

Degelman

ENGINEERED TOUGH

MID WING
HDSR 930
HDSR 1320

LARGE WING
HDSR 1130
HDSR 1520

HDSR

HEAVY DUTY STAGGERED RIPPER



SHATTER COMPACTION WHEN YOUR OPERATION DEMANDS IT

High Performance Ripping

Introducing the all new HDSR line of Heavy Duty Staggered Rippers from Degelman. When your operation needs something more than conventional tillage, look no further. **The HDSR offers aggressive, industry leading 24" maximum ripping depth.** With the under frame clearance of 44", there's plenty of room for crop residue and rocks to pass through the machine, and makes changing points easier and safer.

The Benefits of a Staggered Ripper

The Staggered two row layout provides better trash flow and lower draft than an in-line ripper. It also allows for shorter implement contour length, easier transport, and better compaction shattering ability than a V-ripper.



Scan for More Info

Under Frame Clearance of 44"

That gives plenty of room for crop residue and rocks to pass through the machine. It also makes changing points easier and safer.



Heavy Duty Frame

As with all of our equipment, the frame is heavy duty and engineered tough. We built the frame to penetrate even the hardest, most compacted dirt. There's no need to wait for rain or turn on the irrigation to get your ripper in the ground.

Narrow Transport

With a narrow transport width of just 12 feet 6 inches, and a short transport height of 12 feet, you can quickly fold it up and get to the next field. When you add the chopper rollers, the height increases slightly to 13 feet 11 inches, but can help chop up the large particles for a finer field finish.

True Greaseless Technology

We built the HDSR with the same greaseless technology that goes into our other equipment. The oversized electroless plated nickel pins are used on all of our high wear parts, making this a 95% greaseless machine.



Drop the Pin and Go

Depth change is as easy as adding shims to the wheel cylinders, conveniently located at the front of the machine. The ripper levels itself automatically so no hitch level adjustment is necessary, unlike the competitors. We know every minute of downtime on your operation matters.

Auto Levelling System

The ripper levels itself automatically so no hitch level adjustment is necessary and you can easily change ripping depth without having to exit the tractor and manually crank a turnbuckle to re-level the machine.

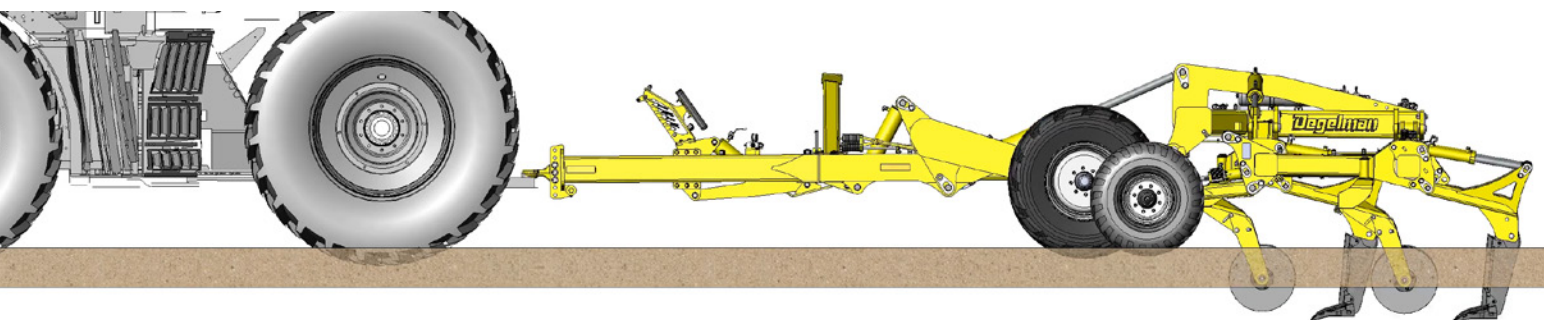

TRIP OPTIONS



Shear Bolt Trip

Optional for producers with loose, sandy soil and few rocks.

Trip Force/Point Load: 9000 lbs



Auto-Reset Spring Trip

Standard option and is suited for fields with loose soil and many rocks.

Trip Force/Point Load: 2800 lbs



Hydraulic Trip

Available for the most punishing conditions of hard soil and numerous rocks.

Trip Force/Point Load: 3000-5000 lbs

SHANK OPTIONS

1-1/4" Thick Straight Shank

Minimum residue disturbance with excellent subsoil tillage.



1-1/4" Thick Parabolic Shank

This shank was designed with aggressive tillage in mind.

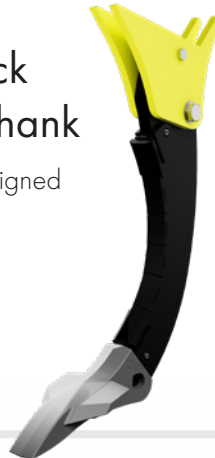

3/4" Thick Min-Till Shank

Offers an undisturbed surface while effectively shattering subsoil compaction.



POINT OPTIONS

Results show during in-field testing and in DEM (discrete element method) simulations that the point has a big effect on surface disturbance and field finish. Larger winged ripper points result in better compaction shattering ability while narrow ripper points result in a better minimum tillage field finish. Proper shank and point selection is key for the results you want to see at your farm.

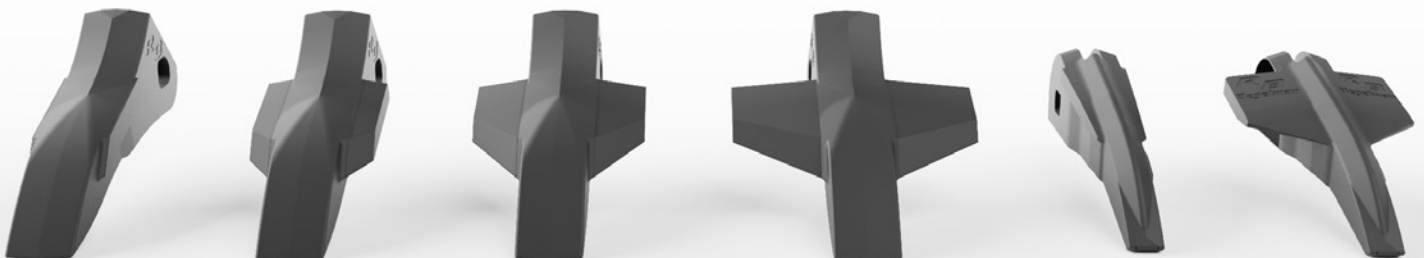

For the thicker 1.25" shank we offer a variety of points ranging from 3" Wingless Points to 10" Winged Points.

For the 3/4" shanks, we offer 2" Narrow Points and 7" Winged Points for a min-till field finish.

Optional Chopper Roller

The optional rear chopper roller effectively crumbles any clumps pulled up by the ripper shanks. Available with standard spring pressure or hydraulic down pressure for extreme conditions



Model	HDSR 930	HDSR 1320	HDSR 1130	HDSR 1520
Working Width	22'-6"	21'-8"	27'-6"	25'-0"
Transport Height (w/o chopper)	12'-0"	12'-0"	12'-1"	12'-1"
Transport Height (with chopper)	13'- 8"	13'- 8"	13'-11"	13'-11"
Transport Width	12'-1"	12'-1"	12'-1"	12'-1"
Transport Length	17'-8"	17'-8"	20'-0"	20'-0"
Field Length (w/o chopper)	25'-2"	25'-2"	27'-8"	27'-8"
Field Length (with chopper)	27'-0"	27'-0"	29'-5"	29'-5"
Outside Wheel Track	10'-8"	10'-8"	10'-8"	10'-8"
Weight (w/o chopper)	18,000 lbs.	20,500lbs.	20,000 lbs.	22,500 lbs.

Optional Coulter Discs

We offer 20" coulter discs that cut surface residue ahead of the shank and reduce implement draft. The coulter disc arms utilize the proven Degelman rubber torsion suspension system which provides a maintenance free and spring free coulter trip design. The coulter mount also casters for corners to reduce mechanical stress.



Weight (with chopper)	20,300 lbs.	22,800 lbs.	22,500 lbs.	25,000 lbs.
Hitch Weight (w/o chopper)	2,800 lbs.	3,200 lbs.	4,000 lbs.	4,600 lbs.
Hitch Weight (with chopper)	3,200 lbs.	3,600 lbs.	4,600 lbs.	5,100lbs.
Number of Shanks	9	13	11	15
Shank Spacing	30"	20"	30"	20"
Optional Chopper Size	17" Diameter X 10'-9" LG		17" Diameter X 12' LG	
Transport Cylinder	6 X 32 X 2.5in - Pin Eye c/w composite bushings and seals		6.5 X 32 X 2.5in - Pin Eye c/w composite bushings and seals	
Standard Equipment	Auto-Level Technology, Hydraulic Park Jack, Safety Lights, Hose/Manual Holder, Compaction Depth Probe			
Points (1-1/4" Shank)	Narrow - 3" Wing - 5", 7", 10"			
Points (3/4" Shank)	Narrow - 2" Wing - 7"			

HORSEPOWER REQUIREMENTS

- * 40 to 45 hp per shank at **14" or less working depth** to achieve 5MPH with 7" winged points (will vary with soil type and shank/point selection)
- * 45 to 50 hp per shank at **14" or more working depth** to achieve 5MPH with 7" winged points (will vary with soil type and shank/point selection)

Horsepower Per Shank

	40	45	50
HDSR Model			
930	360	405	450
1320	520	585	650
1130	440	495	550
1520	600	675	750