

speedblade®

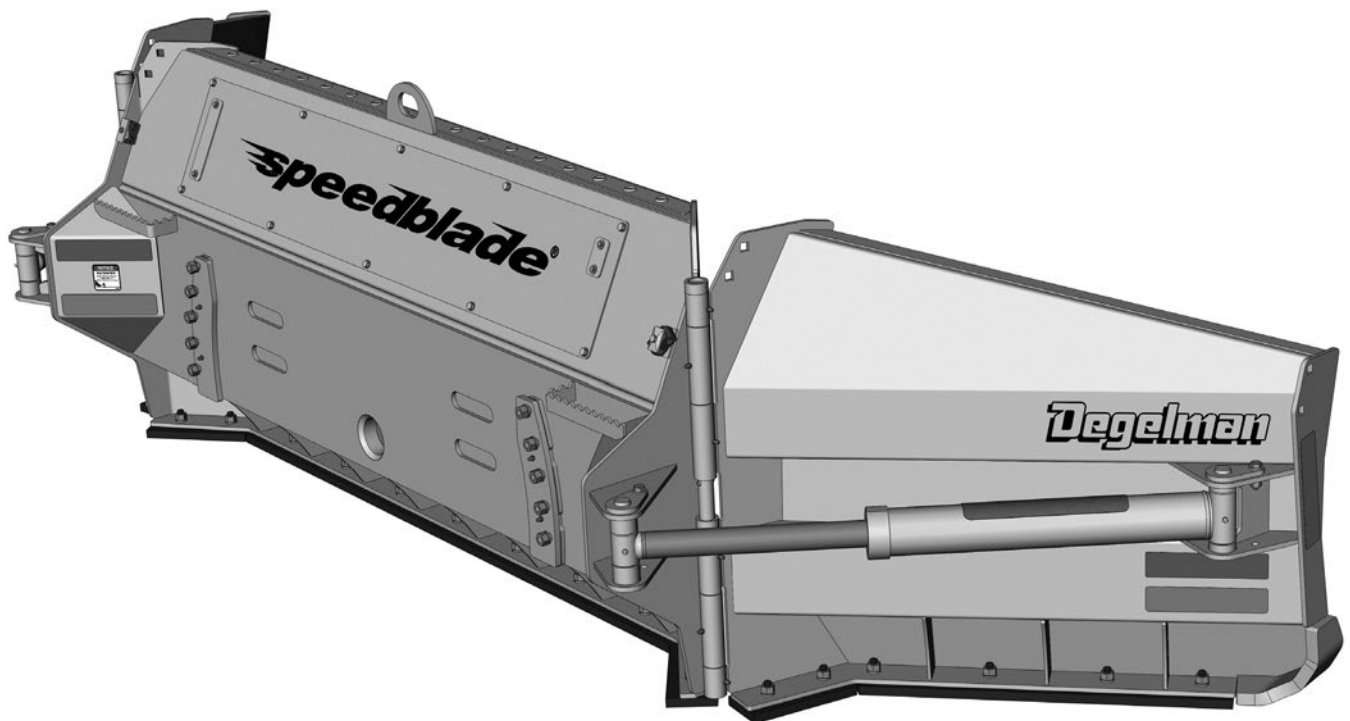

speedblade®

143432 v1.3

DEGELMAN INDUSTRIES LP
BOX 830-272 INDUSTRIAL DRIVE,
REGINA, SK, CANADA, S4P 3B1
FAX 306.543.2140 PH 306.543.4447
1.800.667.3545 DEGELMAN.COM

SPEEDBLADE

QUICK GUIDE INDEX

<i>Introduction</i>	1
<i>Safety</i>	2
<i>Operation</i>	4
<i>Transport & Storage</i>	6
<i>Troubleshooting</i>	7
<i>Maintenance</i>	8
<i>Blade Overall Dimensions</i>	10
<i>Center Section Overview</i>	11
<i>Wing Section Overview</i>	12
<i>Top Extensions</i>	12
<i>Wing Cylinder Components</i>	13
<i>Mounting Options</i>	14
<i>Skidsteer Adapter</i>	14
<i>3-Point Adapter</i>	14
<i>Flatback Loader Adapters</i>	15
<i>46/5700 Dozer Adapter</i>	17
<i>Optional 2-Lever Hydraulics Option</i>	19
<i>Optional Skid Steer Control</i>	20
<i>Warranty</i>	22

Record Serial Number:

.....



Introduction

WELCOME

Degelman is proud to welcome you to our rapidly increasing family of high quality and dependable product owners. This product was designed and built specifically for you, the customer. Through our research and with your input and feedback, we present to you our Degelman Speedblade®.

Designed with durability, safety, and performance in mind, your Speedblade® is ready for years of quality service. In order to help you keep your Speedblade® in top operating condition we have provided you with this manual.

ABOUT THIS MANUAL

This manual has been designed to help you with three extremely important issues: **Operation, Safety, and Maintenance**. It is strongly recommended that you read through the entire manual and review it annually for:

- your own personal safety.
- the safety of others.
- helpful and effective operation techniques.
- maintenance procedures.
- preventative maintenance.

Your authorized Degelman dealer can be contacted for ordering any replacement parts, decals, or manuals. Since many of our parts are specially designed specifically for the Speedblade® we strongly recommend you always replace them with genuine Degelman parts only.

This manual and its contents were current at the time of its first printing. To increase product performance and operation, some part modifications and changes may occur that are not reflected in this manual.

Note: The description "Right" or "Left" as used in this manual is determined by the direction the tractor will travel while in use (unless otherwise stated).

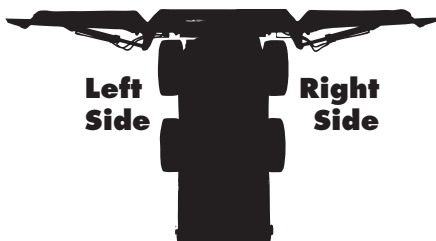

PROOF OF OWNERSHIP

Serial Number Plate



Your **serial number** is found on the serial number plate.

It is important to record the serial and model number of your blade for proof of ownership and for any required service or maintenance assistance.

Serial Number _____

Owner Name _____

Model _____

Purchase Date _____

Dealer Name _____

Address _____

Phone _____

DESCRIPTION

The Speedblade® consists of a two hydraulically controlled multi-position wings blade sections connected to a fixed center blade section.

Typically, the Speedblade® mounts by means of a mounting adapter bracket attached to the center blade section.

The Speedblade® is attachable/detachable with these simple mounting systems.

The Speedblade® has multiple hydraulically controlled ranges of motion – lift, tilt, angle forward, & angle backward.

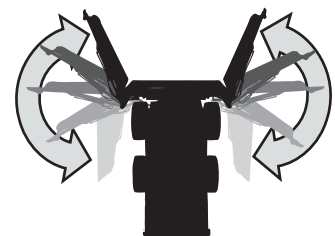

Why is SAFETY important to YOU?

3 BIG Reasons:

- Accidents Can Disable and Kill
- Accidents Are Costly
- Accidents Can Be Avoided

SAFETY ALERT SYMBOL



The **Safety Alert Symbol** means:

**ATTENTION!
BECOME ALERT!
YOUR SAFETY IS INVOLVED!**

The **Safety Alert Symbol** identifies important safety messages applied to the dozer blade and in this manual. When you see this symbol, be alert to the possibility of **injury or death**. Follow the instructions provided on the safety messages.

SIGNAL WORDS

Note the use of the Signal Words: **DANGER**, **WARNING**, and **CAUTION** with the safety messages. The appropriate Signal Word has been selected using the following guidelines:

DANGER: Indicates an imminently hazardous situation that, if not avoided, **WILL** result in death or serious injury if proper precautions are not taken.

WARNING: Indicates a potentially hazardous situation that, if not avoided, **COULD** result in death or serious injury if proper precautions are not taken.

CAUTION: Indicates a potentially hazardous situation that, if not avoided, **MAY** result in minor or moderate injury if proper practices are not taken, or, serves as a reminder to follow appropriate safety practices.

YOU are RESPONSIBLE

... for your own safety and that of others!

- If you are not familiar with basic agriculture & industrial safety, you must get training.
- Owners of equipment must give operating instructions to other operators such as family members or a hired hand.
- Making any design changes to equipment could cause a hazard, damage your machine & void your warranty.

YOU are responsible for the SAFE operation and maintenance of your Degelman implement. YOU must ensure that you and anyone else who is going to operate, maintain, or work around the machine be familiar with the operating and maintenance procedures, and related SAFETY information contained in this manual. This manual will take you step-by-step through your working day and will alert you to good safety practices that should be adhered to while operating this equipment.

Remember, YOU are the key to safety. Good safety practices not only protect you, but also the people around you. Make these practices a working part of your safety program. Be certain that EVERYONE operating this equipment is familiar with the recommended operating and maintenance procedures and follows all the safety precautions. Most accidents can be prevented. Do not risk injury or death by ignoring good safety practices.

- Owners must give operating instructions to operators or employees before allowing them to operate the unit, and at least annually thereafter per OSHA regulation 1928.57.
- The most important safety device on this equipment is a SAFE operator. It is the operator's responsibility to read and understand ALL Safety and Operating instructions in the manual and to follow these. All accidents can be avoided!
- A person who has not read and understood ALL operating and safety instructions is not qualified to operate the machine. An untrained operator exposes himself and bystanders to possible serious injury or death.
- Do not modify the equipment in any way. Unauthorized modification may impair the function and/or safety and could affect the life of the equipment.

Safety

GENERAL SAFETY

1. Read and understand the Operator's Manual and all safety signs before using. Review safety related items with all operators annually.
2. Lower blade to ground, stop engine, place all controls in neutral, set park brake and remove ignition key before servicing, adjusting or repairing.
3. Keep hands, feet, hair and clothing away from all moving and/or rotating parts.
4. DO NOT allow riders on the machine or Speedblade® during operation or transporting.
5. Clear the area of all bystanders, especially children, before starting.
6. DO NOT operate machine on steep side hills or slopes.
7. Be careful when working around or maintaining a high-pressure hydraulic system. Ensure all components are tight and in good repair before starting.
8. Clean all reflectors and lights before transporting on a highway or public road. Be sure to check with local highway authorities and comply with their lighting requirements.
9. Stay well back from machine when operating. Keep others away.
10. Be aware of wing operation range and pinch-point areas.
11. Be aware of slippery areas when entering/exiting the skid steer.

Prepare for Emergencies

- Keep a first aid kit and fire extinguisher handy.
- Keep emergency numbers for doctor, hospital, ambulance, and fire department near your phone.



Doctor _____

Ambulance _____

Hospital _____

Fire Department _____

Wear Protective Equipment

Note: Before working on machine, always turn tractor off, set controls in neutral, and remove ignition key.

- Wear proper safety equipment such as safety glasses and shoes, hearing protection, hard hats, or any other appropriate items to prevent injury.

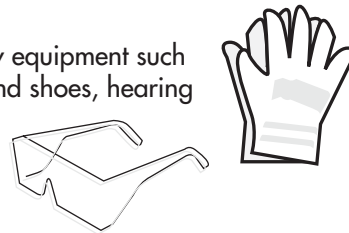

- Loss of hearing or hearing impairment may result from prolonged exposure to loud noise. Wear suitable hearing protective devices such as earmuffs or earplugs to protect your hearing.
- Safely operating this equipment requires the full attention of the operator. Do not wear radio or music headphones, or talk on your phone while operating this machine. Never operate while under the influence of alcohol or drugs or allow anyone under the influence to operate the tractor.

⚠ HYDRAULIC

- Keep all parts clean.
- Replace worn or damaged parts.
- Don't try any makeshift repairs.
- Before operating check that everything is tight and not broken.
- Wear gloves and eye protection when searching for leaks. Use a piece of wood or cardboard but not your hand. High pressure oil will penetrate your skin. If that happens you risk serious injury.

⚠ BLADE

- Lower blade to the ground when not in use.
- Keep clear of blade when tractor is running.
- Keep hands & feet away from under blade.
- Turn engine off when hooking up hydraulics and during mounting or dismounting.

⚠ TRANSPORTING

- Lift blade up then fold wings completely forward.
- Make sure reflectors are clean.
- Use your hazard lights.

Operation

TO THE NEW OPERATOR OR OWNER

The Degelman *Speedblade*® is a push type tractor attachment designed primarily for pushing and removal of snow.

It is the owners or operators responsibility to read this manual carefully to learn how to operate the machine safely and how to set it to provide maximum efficiency. Safety is everyone's business. By following safe operating practices, a safe environment is provided for the operator and bystanders.

The manual will take you step-by-step through your working day. By following the operating instructions in conjunction with a good maintenance program your machine will provide many years of trouble-free service.

PRINCIPLES OF OPERATION

The *Speedblade*® consists of a blade/cutting edge unit attached to a tractor unit by the front mount adapter bracket. By driving the tractor forward with the blade either straight ahead or angled, and allowing the cutting edge to run just on top of the ground surface - snow is relocated as desired.

BREAK-IN

Although there are no operational restrictions on the *Speedblade*® when it is new, there are some mechanical checks that must be done to ensure the long term integrity of the unit. When using the machine for the first time, follow this procedure:

A. Before using:

1. Read Operator's Manual.
2. Lubricate all points shown in the Maintenance Section.
3. Check all bolt tightness.

B. After operating for 2 hours:

1. Check all hardware.
2. Check all hardware tightness.
3. Check all hydraulic system connections. Tighten if any are leaking.

C. After operating 10 hours:

1. Repeat Step B.
2. Go to the service schedule as outlined in the Maintenance Section.

TRACTOR PREPARATION

Check Hydraulic Oil Level:

Check the oil level in the tractor hydraulic system daily. Refer to your tractor operator's Manual for Instructions. Keep the oil supply up to the proper level. Before checking oil supply, fully extend and retract angle and lift cylinders 3 - 4 times and return the blade to the ground.

 **IMPORTANT:** The *Speedblade*® hydraulic system is pre-charged and tested with Boss UTF (Universal Tractor Fluid) hydraulic oil. To avoid oil contamination, check and confirm the current fluid type used in your tractor matches this pre-loaded system prior to hook-up.

ATTACHING THE DOZER BLADE

NOTE: Please refer to the parts section of this manual - for additional hydraulic/electrical information.

Mounting:

1. Attach tractor unit to *Speedblade*™ using the mount adapter.
2. Hook-up Hydraulics.
3. Route electrical wiring harness/button end into cab and fasten button to left controller.
4. Connect the power supply wiring harness end to an optional electrical outlet or other 12V power source. **Note:** Use a 20A in-line fuse.

BLEEDING THE HYDRAULICS

Before beginning operation, bleed the hydraulic system to remove any air. To do this, cycle the hydraulics several times by holding the cylinder fully extended for several seconds. This will cause any trapped air to be purged from cylinder.

COLD WEATHER OPERATION

To assure smooth operation in cold weather, cycle the cylinders several times to warm the oil in the hydraulic system.

Operation

OPERATOR'S RESPONSIBILITY

Every operator should read this manual and be instructed in safe operating procedures. An untrained operator is not qualified to operate this machine and could place themselves or bystanders in danger.

BLADE SETTING

Ensure the *Speedblade*[®] edges run parallel to the ground.



Gauge the blade down pressure to push the most material possible without losing speed through spinning the wheels or slowing the tractor engine. This is achieved by regulating the blade height with the lifting cylinder operating lever.



ANGLING DOZER BLADE

The *Speedblade*[®] wings can be hydraulically angled individually approximately 80° forward and 55° backward. In the angled position, the dozer blade can be used for windrowing, scooping or pushing snow depending on wing positions.

- Angling the **right wing** is achieved by operating the proper remote cylinder lever.
- Angling the **left wing** is achieved by operating the proper remote cylinder lever and depressing the button switch. (*Depressing the button switch activates an electric selector valve that toggles control of the left wing cylinder.*)



IMPORTANT:

- To avoid damage to tractor unit or blade, the hydraulic system must be hooked up properly.
- Wing cylinder stops may be required by some tractor unit configurations to avoid contact with tractor unit/front tires when blade is fully angled. Ensure proper range of motion is unrestricted before operating.

OPERATING SPEED

For normal operation, operate the tractor at a comfortable or manufacturer recommended speed. When operating over rough terrain or limited to space, reduce engine speed. The actual forward speed will be determined by tractor horsepower, snow density and down pressure.

Experience will teach you the most efficient operating speed.

FLOATING THE DOZER BLADE

Here are some the things you can do with your hydraulic system in float position:

- Skim the top of pavement
- Back drag
- Contour ground surface

By placing the remote cylinder operating lever for the lift function in float position, the blade may be used to smooth an area by running the tractor in reverse (refer to Tractor Operator's Manual). On moderate grades, the tractor can be driven up the slope and the blade dropped down for back-dragging.

PRE-OPERATION CHECKLIST

Efficient and safe operation of the *Speedblade*[™] requires that each operator reads and understands the operating procedures and all related safety procedures outlined in this manual.

Before Using for the FIRST Time

- Lubricate all points
- Torque all hardware to correct setting
- Check hardware torque & hydraulics after the first 2 hrs & again after 10 hrs.

Before Using EVERY Time

- Check:**
- If all points lubricated
 - All components attached securely
 - Condition of cutting edge
 - Depth/skid shoe wear
 - Hydraulics:
 - Tractor's oil reservoir
 - Condition of hoses, lines & fittings

Transport & Storage

TRANSPORT SAFETY

- Read and understand ALL the information in the Operator's Manual regarding procedures and SAFETY when operating the machine in the field/yard or on the road.
- Check with local authorities regarding machine transport on public roads. Obey all applicable laws and regulations.
- Always travel at a safe speed. Use caution when making corners or meeting traffic.
- Make sure the SMV (Slow Moving Vehicle) emblem and all the lights and reflectors that are required by the local highway and transport authorities are in place, are clean and can be seen clearly by all overtaking and oncoming traffic.
- Keep to the right and yield the right-of-way to allow faster traffic to pass. Drive on the shoulder, if permitted by law.
- Always use hazard warning flashers on tractor when transporting, unless prohibited by law.

TRANSPORTING

Follow this procedure when preparing to transport:

1. Clear the area of bystanders, especially small children, before converting into transport configuration.
2. Operate the lift hydraulics to raise the blade off the ground and fold the wings completely forward.
3. Clean the SMV sign, lights and reflectors.
4. Maintain a safe speed. Slow down when cornering and on rough roads.
5. Slow down and pull off to the side of the road when meeting other traffic.
6. Use hazard flashers on tractor unless prohibited by law.

STORAGE SAFETY

- Store unit in an area away from human activity.
- Do not permit children to play near the stored unit.

STORAGE

After the season's use, completely inspect all major systems of the machine. Repair or replace any worn or damaged components to prevent unnecessary down time at the beginning of next season.

Since the unit can be used in extremely adverse conditions during the season, the machine should be carefully prepared for storage to ensure that all dirt, mud, debris and moisture has been removed.

Follow this procedure when preparing to store:

1. Wash the entire machine thoroughly using a water hose or pressure washer to remove all dirt, mud, debris or residue.
2. Inspect all parts to see if anything has become entangled in them. Remove the entangled material.
3. Lubricate all grease fittings to remove any moisture.
4. Inspect all hydraulic hoses, fittings, lines and couplers. Tighten any loose fittings. Replace any hose that is badly cut, nicked or abraded or is separating from the crimped end of the fitting.
5. Touch up all paint nicks and scratches to prevent rusting.
6. Oil the exposed rams on the hydraulic cylinder to prevent rusting.
7. Select an area that is dry, level and free of debris.

Troubleshooting

GENERAL TROUBLESHOOTING

SYMPTOM	PROBLEM	SOLUTION
Cutting edge wearing excessively in center of the blade.	High downward force of dozer in contact with crown of road.	Ensure blade cutting edge runs parallel to the ground.
	Blade tilted forward too much causing improper wear.	
Cutting edge wearing excessively at ends of the blade.	High downward force on ends of dozer.	Run lift function in float.
	Blade tilted forward or backward too much causing improper wear.	Change operation to prevent this type of contact. Ensure blade cutting edge runs parallel to the ground.
Breaking cutting edge bolts.	Cutting edge bolts not properly torqued.	Under torqued bolts allows impact to break bolts.
	Torque 5/8" Gr.8 bolts to 225 lb-ft Torque 3/4" Gr.8 bolts to 400 lb-ft	Over torqued bolts can fail from too much tension loading.
Loose tilt ring components.	Loosening of tilt ring hardware over time.	Check hardware and re-tighten as required.
Only RH (right hand) wing works.	Button switch must be depressed for LH wing.	Depress button switch for LH wing operation, release button to operate the RH wing. <i>(Depressing the button switch activates an electric selector valve that toggles control of the left wing cylinder)</i>
	Electrical connections may be faulty.	Locate and repair faulty electrical connections.

Maintenance

MAINTENANCE SAFETY

1. Review the Operator's Manual and all safety items before working with, maintaining or operating the machine.
2. Lower machine to ground, stop the tractor engine, place all controls in neutral, set park brake and remove ignition key before servicing, adjusting or repairing.
3. Clear the area of bystanders, especially children when carrying out any maintenance and repairs or making adjustments.
4. Place safety stands or large blocks under the frame before removing tires or working beneath the machine.
5. Be careful when working around or maintaining a high-pressure hydraulic system. Wear proper eye and hand protection when searching for a high pressure hydraulic leak. Use a piece of wood or cardboard as a backstop when searching for a pin hole leak in a hose or a fitting.
6. Always relieve pressure before disconnecting or working on hydraulic system.

HYDRAULIC SAFETY

1. Always place all tractor hydraulic controls in neutral before dismounting.
2. Make sure that all components in the hydraulic system are kept in good condition and are clean.
3. Replace any worn, cut, abraded, flattened or crimped hoses and metal lines.
4. Do not attempt any makeshift repairs to the hydraulic lines, fittings or hoses by using tape, clamps or cement. The hydraulic system operates under extremely high pressure. Such repairs will fail suddenly and create a hazardous and unsafe condition.
5. Wear proper hand and eye protection when searching for a high pressure hydraulic leak. Use a piece of wood or cardboard as a backstop instead of hands to isolate and identify a leak.
6. If injured by a concentrated high-pressure stream of hydraulic fluid, seek medical attention immediately. Serious infection or toxic reaction can develop from hydraulic fluid piercing the skin surface.
7. Before applying pressure to the system, make sure all components are tight and that lines, hoses and couplings are not damaged.

Think SAFETY! Work SAFELY!

HARDWARE/HOSE SPECIFICATIONS

Unless otherwise stated:

- Hardware: Hex, Plated GR5 UNC (imperial) or P8.8 (metric)
- Hoses: 3/8", ends come with 3/4 JIC female swivel.



IMPERIAL TORQUE SPECIFICATIONS

(based on "Zinc Plated" values)

Size	Grade 8	
	Grade 5 lb. ft (N.m)	Grade 8 lb. ft (N.m)
1/4"	7 (10)	10 (14)
5/16"	15 (20)	20 (28)
3/8"	25 (35)	35 (50)
7/16"	40 (55)	60 (80)
1/2"	65 (90)	90 (120)
9/16"	90 (125)	130 (175)
5/8"	130 (175)	180 (245)
3/4"	230 (310)	320 (435)
7/8"	365 (495)	515 (700)
1"	550 (745)	770 (1050)
1-1/8"	675 (915)	1095 (1485)

HYDRAULIC FITTING TORQUE

Size	lb. ft (N.m)
3/4	75 (100)
7/8	90 (122)

METRIC TORQUE SPECIFICATIONS

(based on "Zinc Plated" values)

Size	Class 8.8		Class 10.9	
	Class 8.8 lb. ft (N.m)	Class 10.9 lb. ft (N.m)	Class 8.8 lb. ft (N.m)	Class 10.9 lb. ft (N.m)
M6	7 (10)	10 (14)	7 (10)	10 (14)
M8	16 (22)	23 (31)	16 (22)	23 (31)
M10	30 (42)	45 (60)	30 (42)	45 (60)
M12	55 (75)	80 (108)	55 (75)	80 (108)
M14	90 (120)	125 (170)	90 (120)	125 (170)
M16	135 (185)	195 (265)	135 (185)	195 (265)
M18	190 (255)	270 (365)	190 (255)	270 (365)
M20	265 (360)	380 (515)	265 (360)	380 (515)
M22	365 (495)	520 (705)	365 (495)	520 (705)
M24	460 (625)	660 (895)	460 (625)	660 (895)
M27	675 (915)	970 (1315)	675 (915)	970 (1315)

Maintenance

CHECK HARDWARE TORQUE

IMPORTANT: Check torque on all hardware periodically. Check after first 2, 10, 40, then every 200 hours.



- Torque values listed are for general use only. If a different torque value or tightening procedure is specified for a specific application, do not use these values.
- Refer to the “Parts” section for proper grade and length of bolts for replacement parts.
- Do not replace locknuts with nuts and lock washers. Replace all parts with original, specified parts only.
- Dry values shown mean the bolt/nut is plain or zinc plated without any lubrication.

HYDRAULIC FLUID

1. The hydraulic system is pre-charged & tested with Boss UTF (Universal Tractor Fluid) hydraulic oil.

 IMPORTANT: To avoid oil contamination, check & confirm the current fluid type used in your tractor matches this pre-loaded system prior to hook-up.

LUBRICANTS

1. Grease: Use an SAE multi-purpose grease with extreme pressure (EP) performance. Also acceptable is an SAE multi-purpose lithium base grease.
2. Storing Lubricants: Your machine can operate at top efficiency only if clean lubricants are used. Use clean containers to handle all lubricants. Store them in an area protected from dust, moisture and other contaminants.

GREASING

1. Use only a hand-held grease gun for all greasing.
2. Wipe grease fitting with a clean cloth before greasing, to avoid injecting dirt.
3. Replace and repair broken fittings immediately.
4. If fittings will not take grease, remove and clean thoroughly. Also clean lubricant passageway. Replace fitting if necessary.
5. Inject grease until you see grease being expelled from the pin or bushing areas.

LUBE AFTER EVERY 8 HRS.

 Items to Grease	Qty.
Tilt Ring	2 per side
Tilt Bell Plate	1 per side
Tilt Bell Bushing	1 location
Angle Cylinder Pins	2 per cylinder
Hinge Pins	6 per side

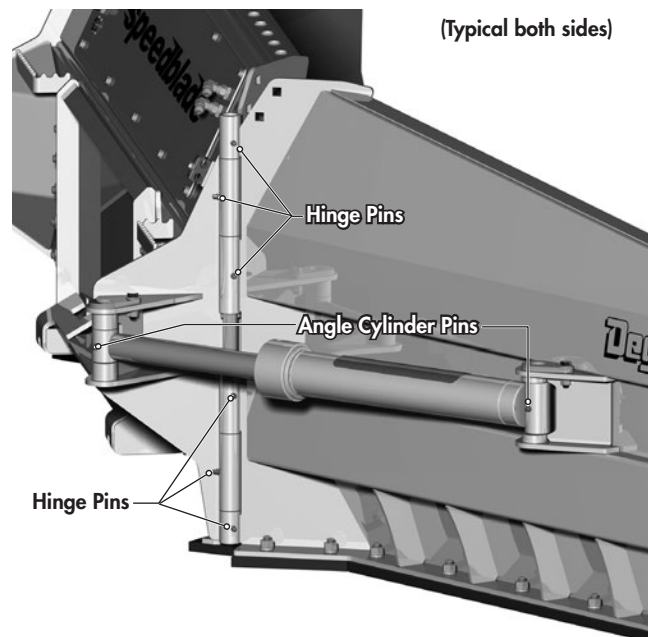
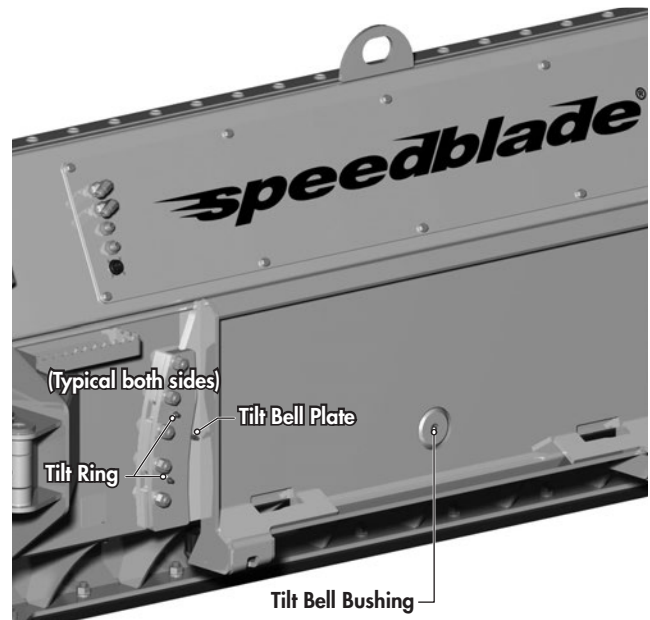

Maintenance

SAFETY DECALS

1. Keep safety decals and signs clean and legible at all times.
2. Replace safety decals and signs that are missing or have become illegible.
3. Replaced parts that displayed a safety sign should also display the current sign.
4. Safety decals or signs are available from your Dealer Parts Department. Safety decals will be available upon request.

How to Install Safety Decals:

- Be sure that the installation area is clean and dry.
- Decide on the exact position before you remove the backing paper.
- Remove the smallest portion of the split backing paper.
- Align the decal over the specified area and carefully press the small portion with the exposed sticky backing in place.
- Slowly peel back the remaining paper and carefully smooth the remaining portion of the decal in place.

REPLACEMENT DECALS

Decals, especially safety and reflective, should be replaced when they become damaged or worn. Contact your dealer.

Reflective Decals

142556	Red Reflector, 2 x 9	4
142557	Amber Reflector, 2 x 9	4
142650	Fluorescent Reflector, 2 x 9	4

Product Decals

143198	Degelman Logo, 36 lg	1
142009	Degelman Logo, 16-1/4 lg	2
143281	Speedblade® Decal	1

OVERALL DIMENSIONS

speedblade®

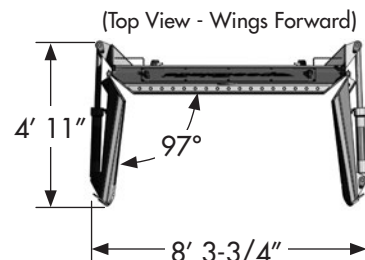
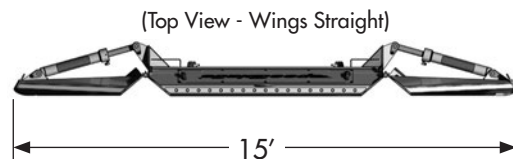
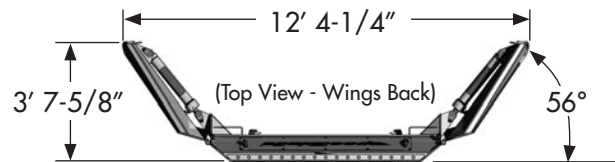
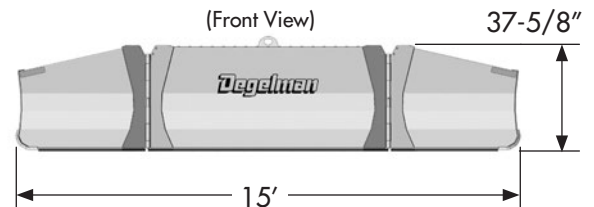
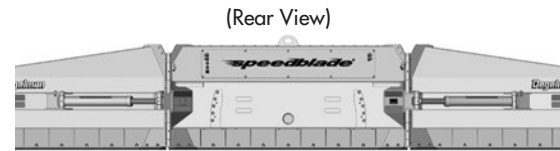

Center Section Overview

CENTER SECTION COMPONENTS

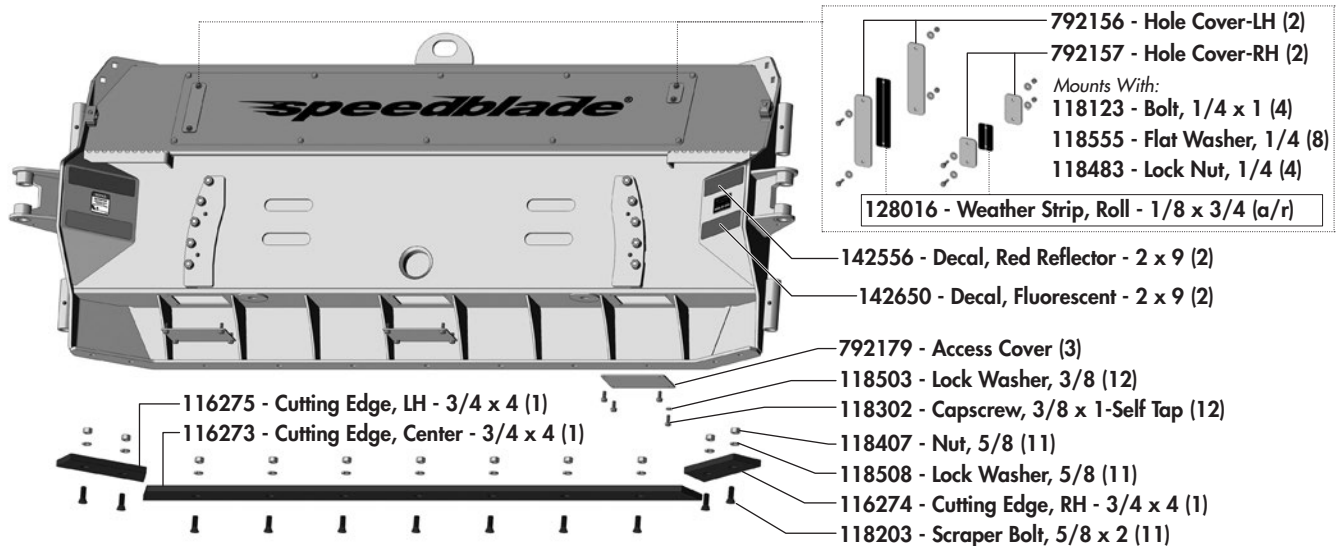
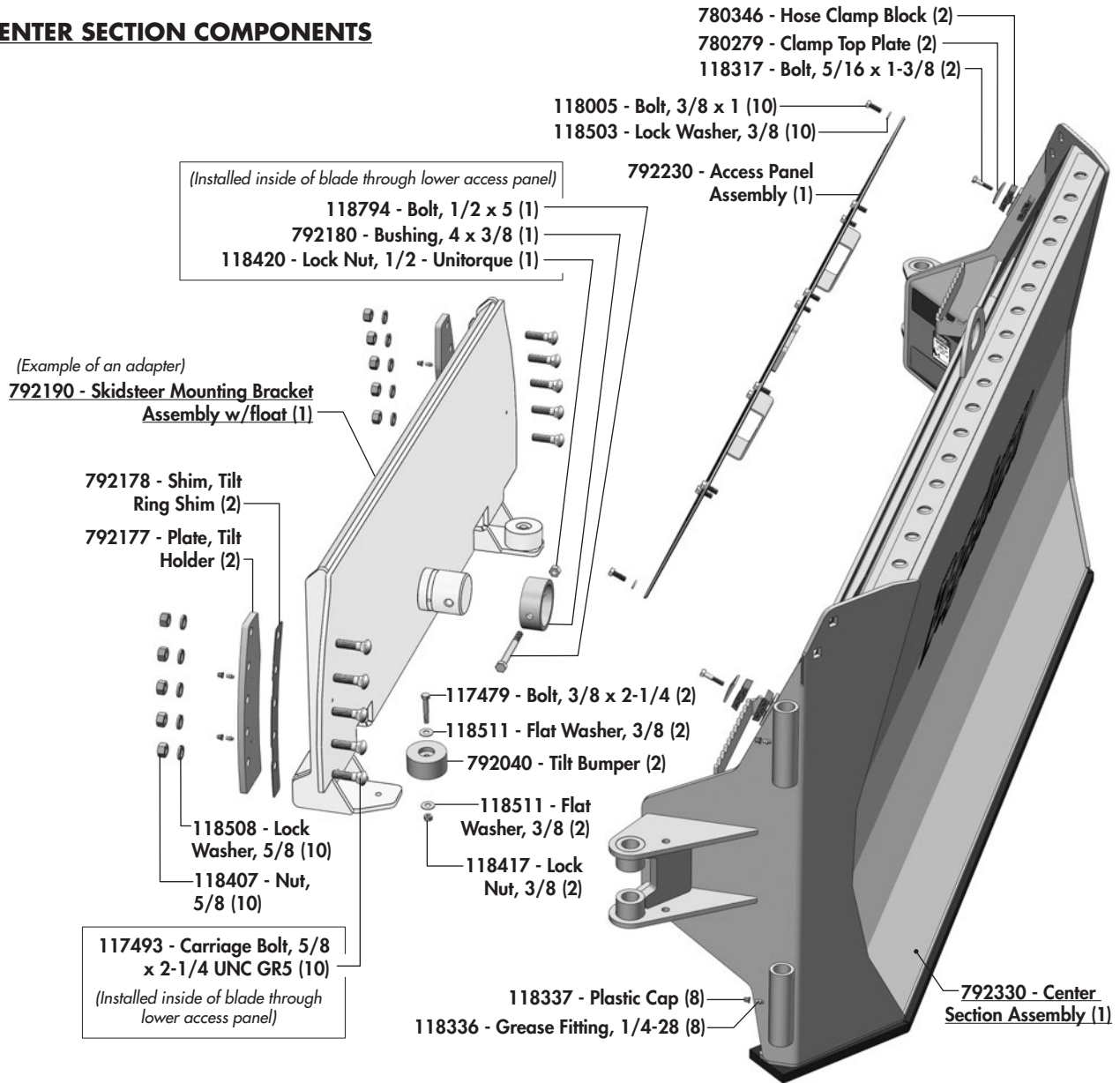

Wing Section Overview

15' WING SECTION

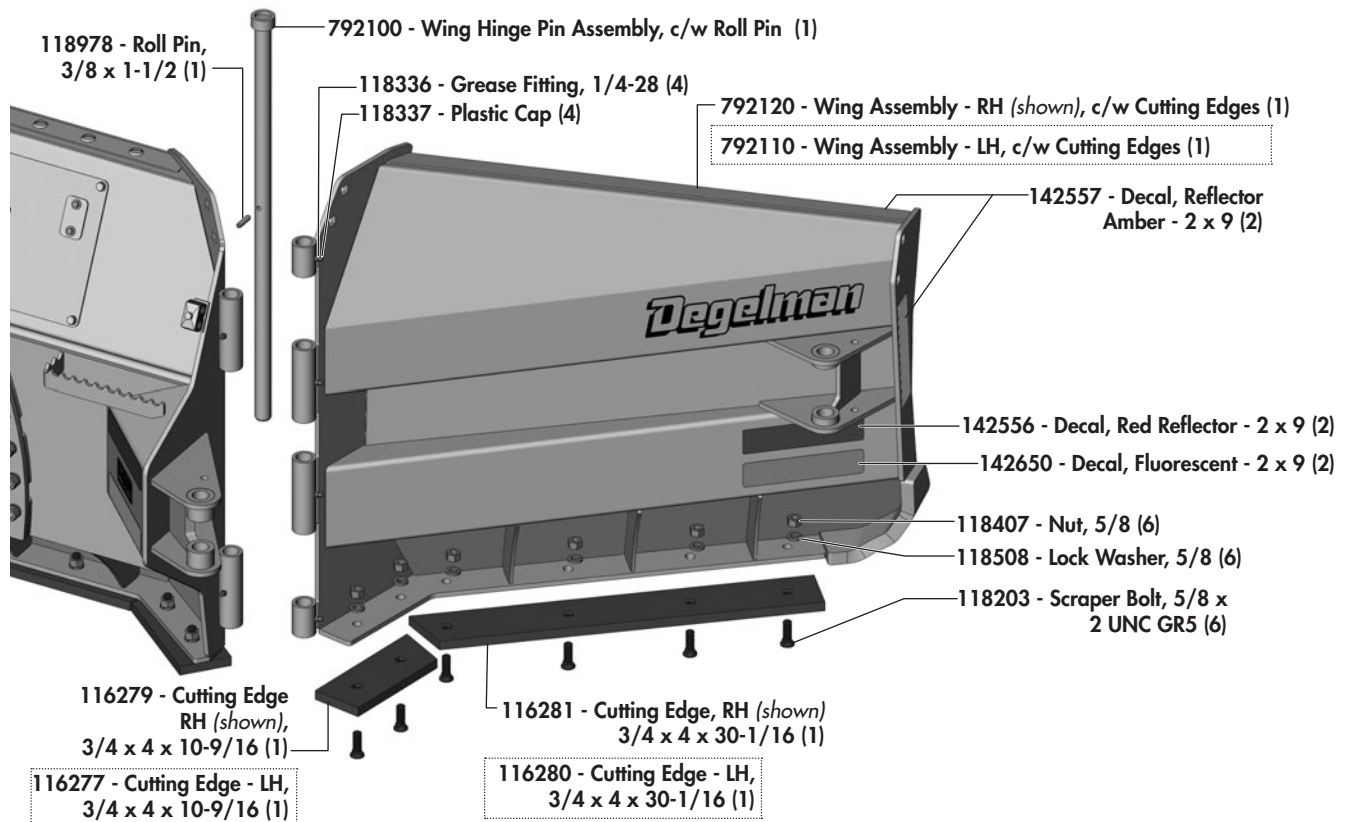

OPTIONAL TOP EXTENSIONS

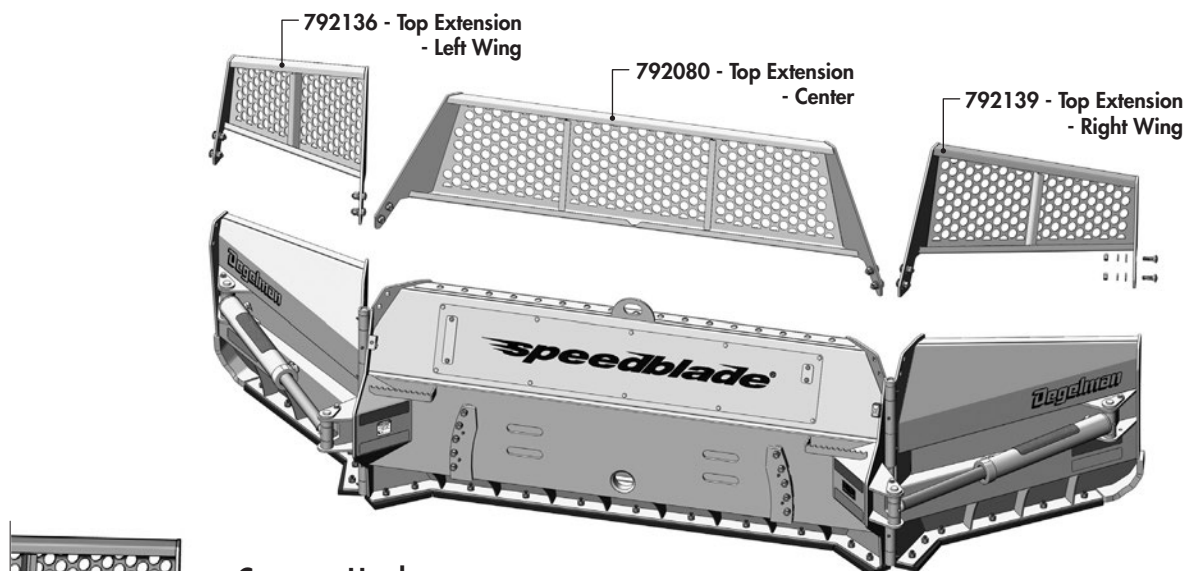

Common Hardware

Each top extension section requires the following hardware.

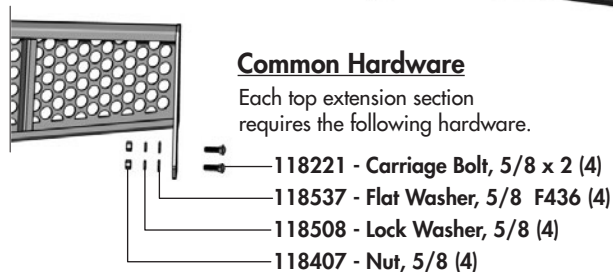

Wing Cylinder Components

(Note: Skid Steer Control Kit
Hose Routing displayed)

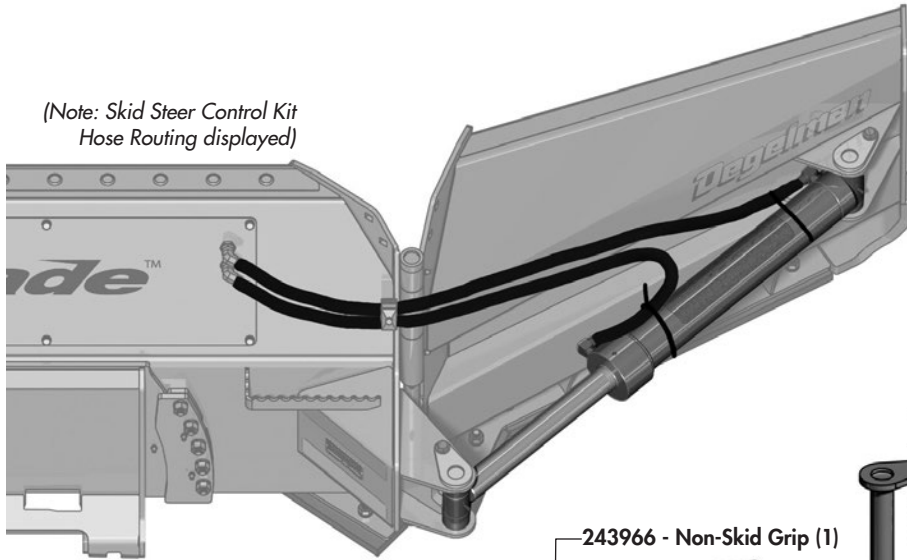

! IMPORTANT: The hydraulic system is pre-charged and tested with **Boss UTF (Universal Tractor Fluid)** hydraulic oil. To avoid oil contamination, check and confirm the current fluid type used in your tractor matches this pre-loaded system prior to hook-up.

- 118292 - Bolt, 1/2 x 1-3/4 (2)
- 118587 - Flat Washer, 1/2 SAE (2)
- 792045 - Cylinder Pin, 1-1/4 x 6 (2)
- 118587 - Flat Washer, 1/2 SAE (2)
- 118504 - Lock Washer, 1/2 (2)
- 118405 - Nut, 1/2 (2)
- 243966 - Non-Skid Grip (1)
- 123070 - Cyl, Monarch - 3 x 20 x 2 (1)
- 123071 - Seal Kit (1)

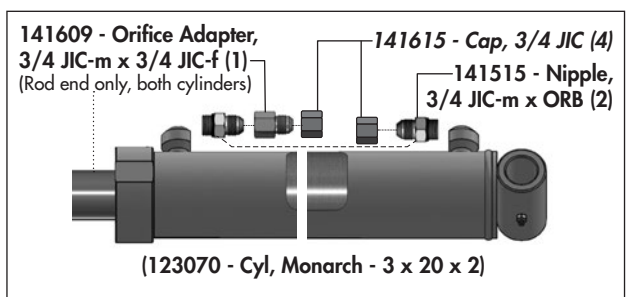

Mounting Options

SKIDSTEER ADAPTER

792199 - Skidsteer Adapter Kit (1)

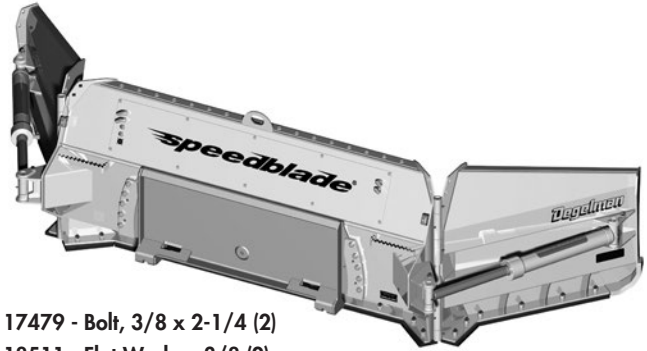
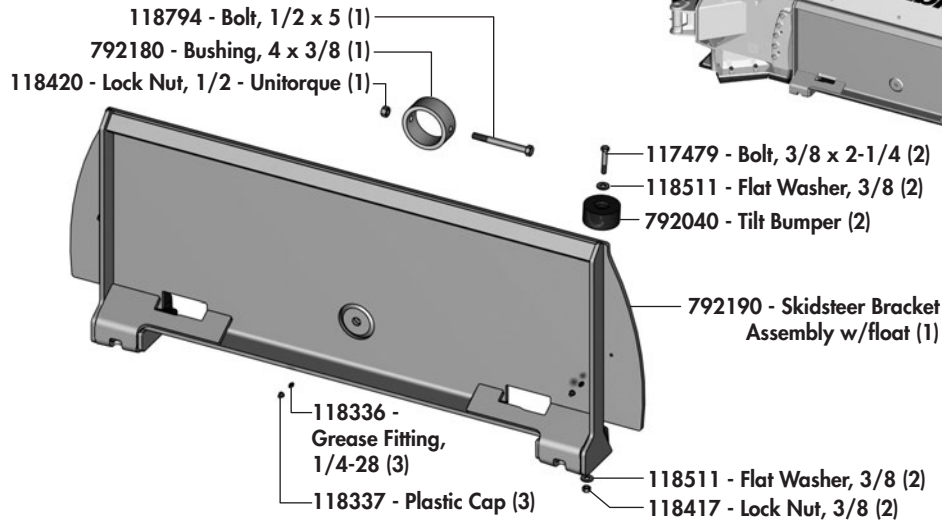

3-POINT ADAPTER - CAT 2 & 3N

792240 - 3-Point Adapter Kit - CAT 2 & 3N (1)

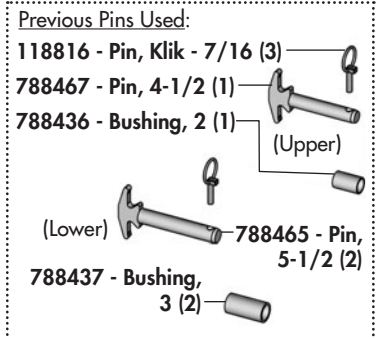
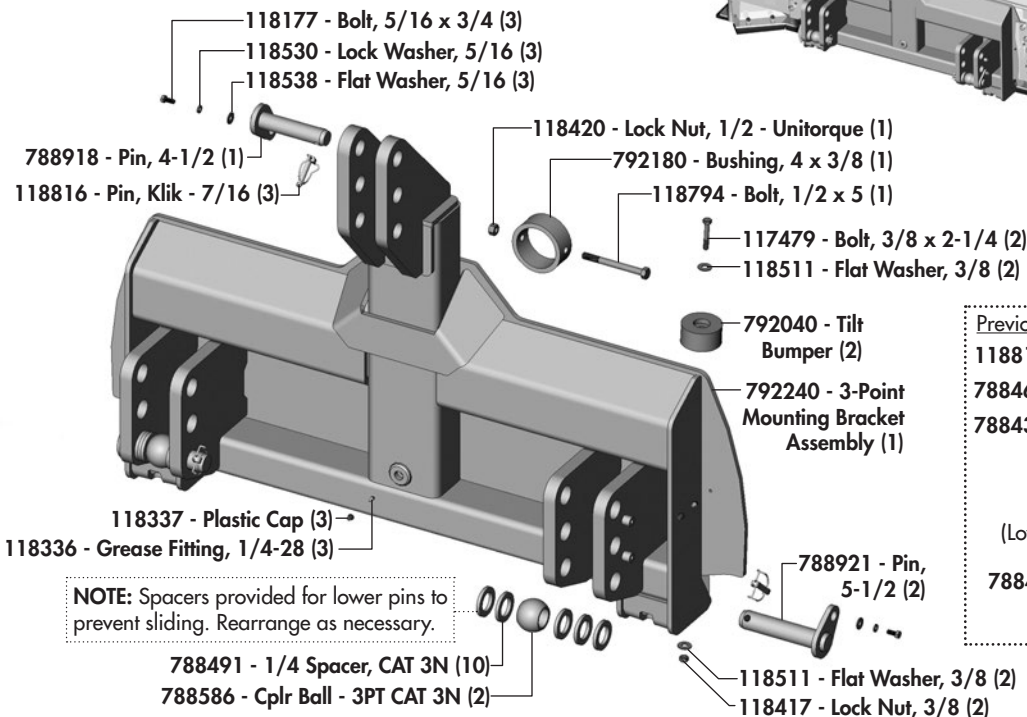

NOTE: Spacers provided for lower pins to prevent sliding. Rearrange as necessary.

Mounting Options

FLATBACK LOADER ADAPTER - STANDARD

792220 - Flatback Loader Adapter Kit - Standard (1)

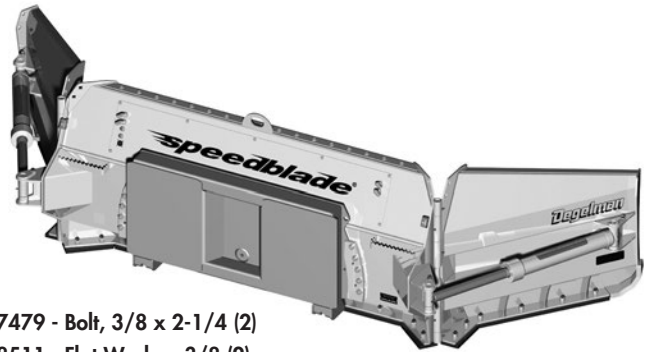
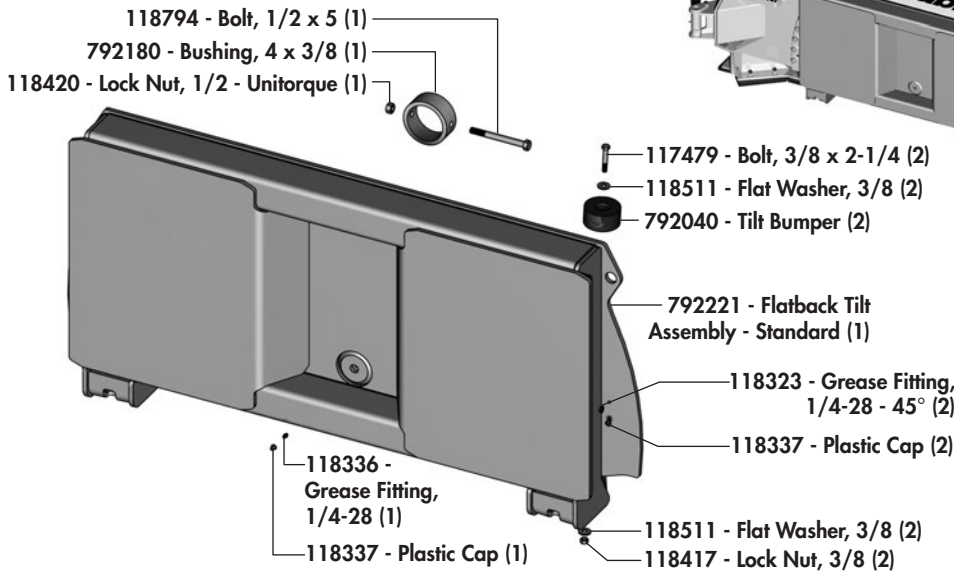

GLOBAL 1 LOADER ADAPTER - STANDARD

792250 - Global 1 Loader Adapter Kit - 24 Degree Option (1)

792275 - Global 1 Loader Adapter Kit - 8 Degree Option (1)

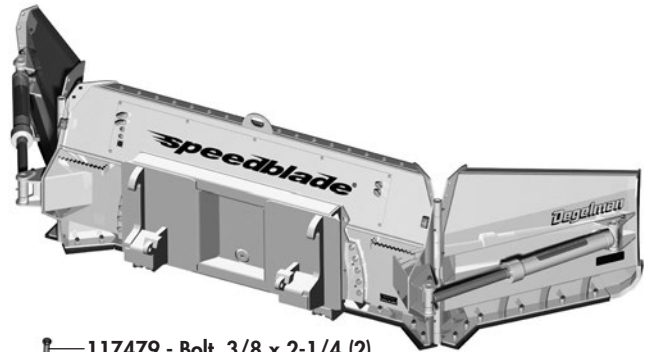
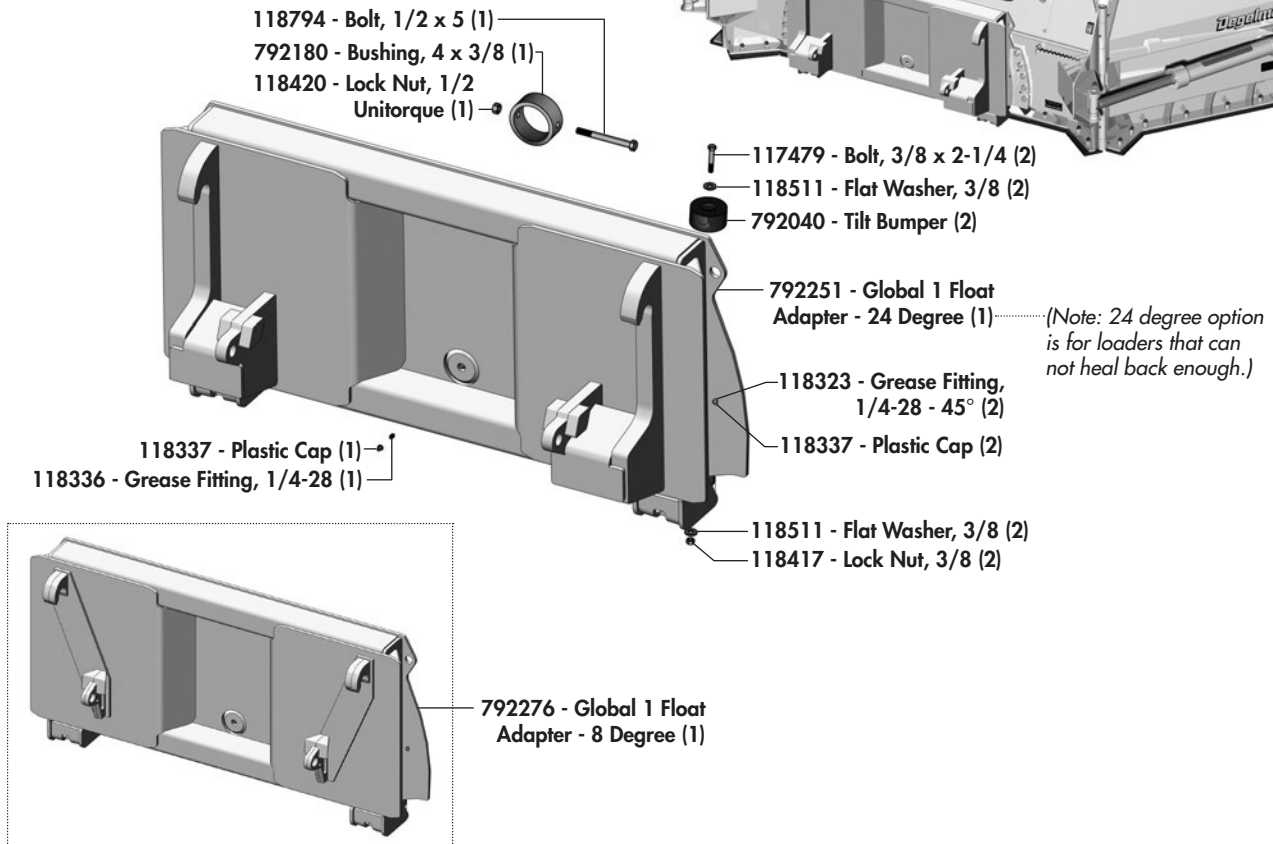

Mounting Options

FLATBACK LOADER ADAPTER - WIDE

792260 - Flatback Loader Adapter Kit - Wide (1)

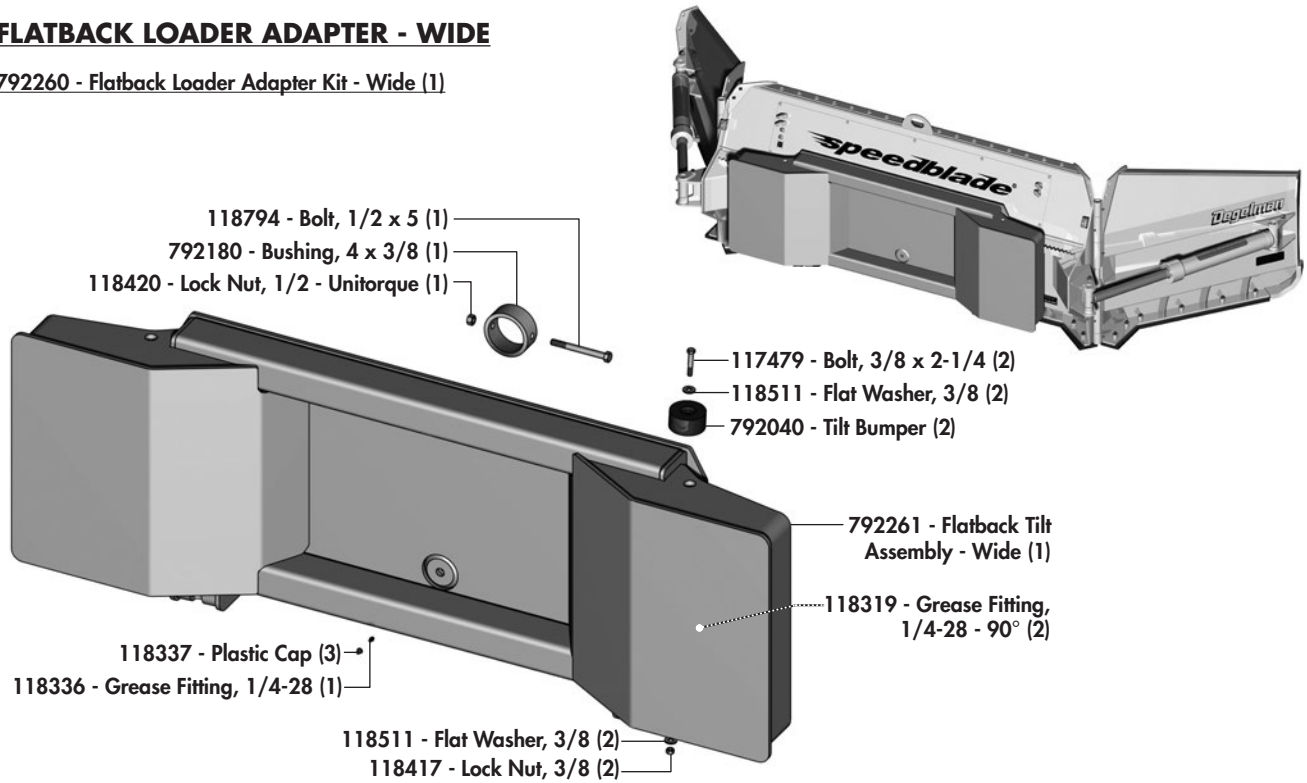

GLOBAL 2 LOADER ADAPTER - WIDE

792340 - Global 2 Loader Adapter Kit - Wide (1)

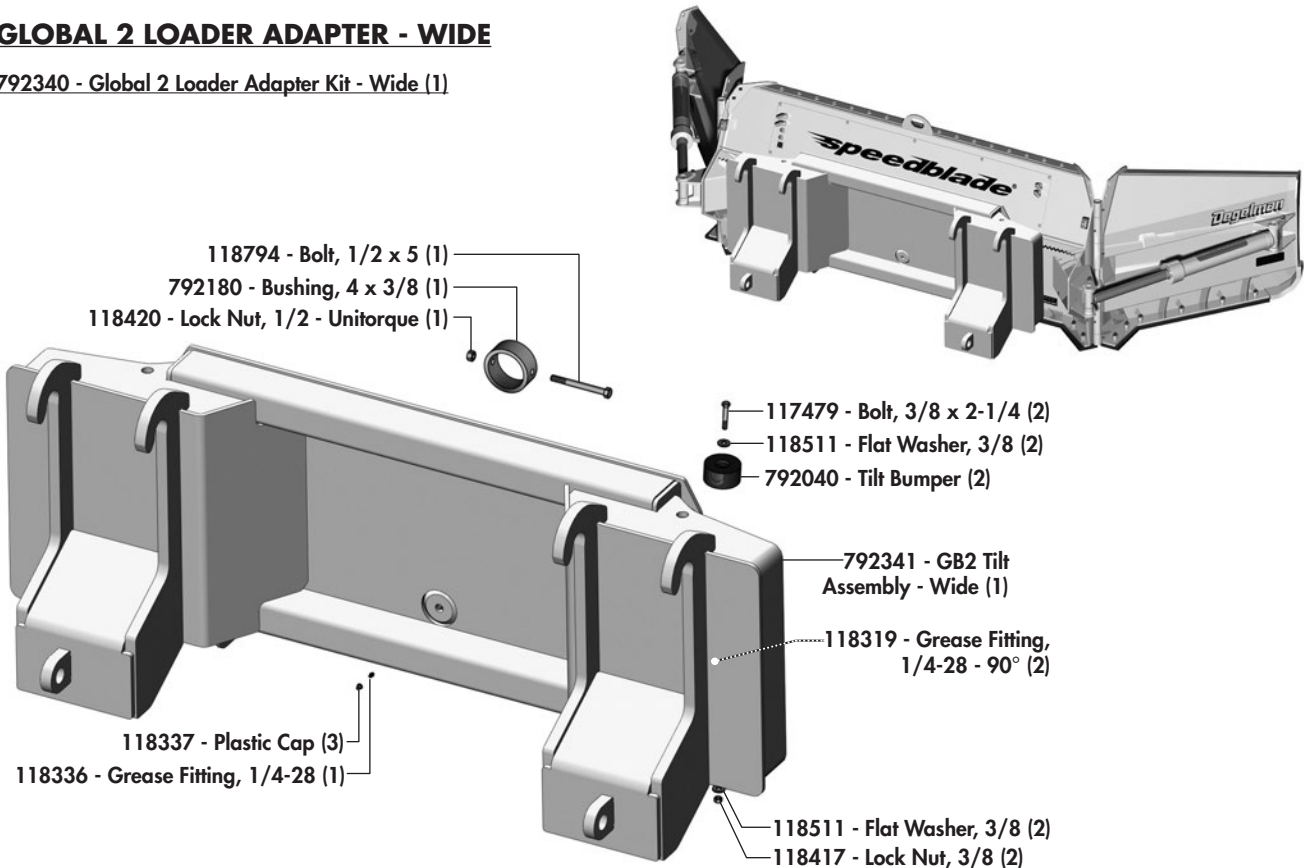

Mounting Options

46/5700 DOZER ADAPTER

792280 - 46/5700 Dozer Adapter Kit (1)

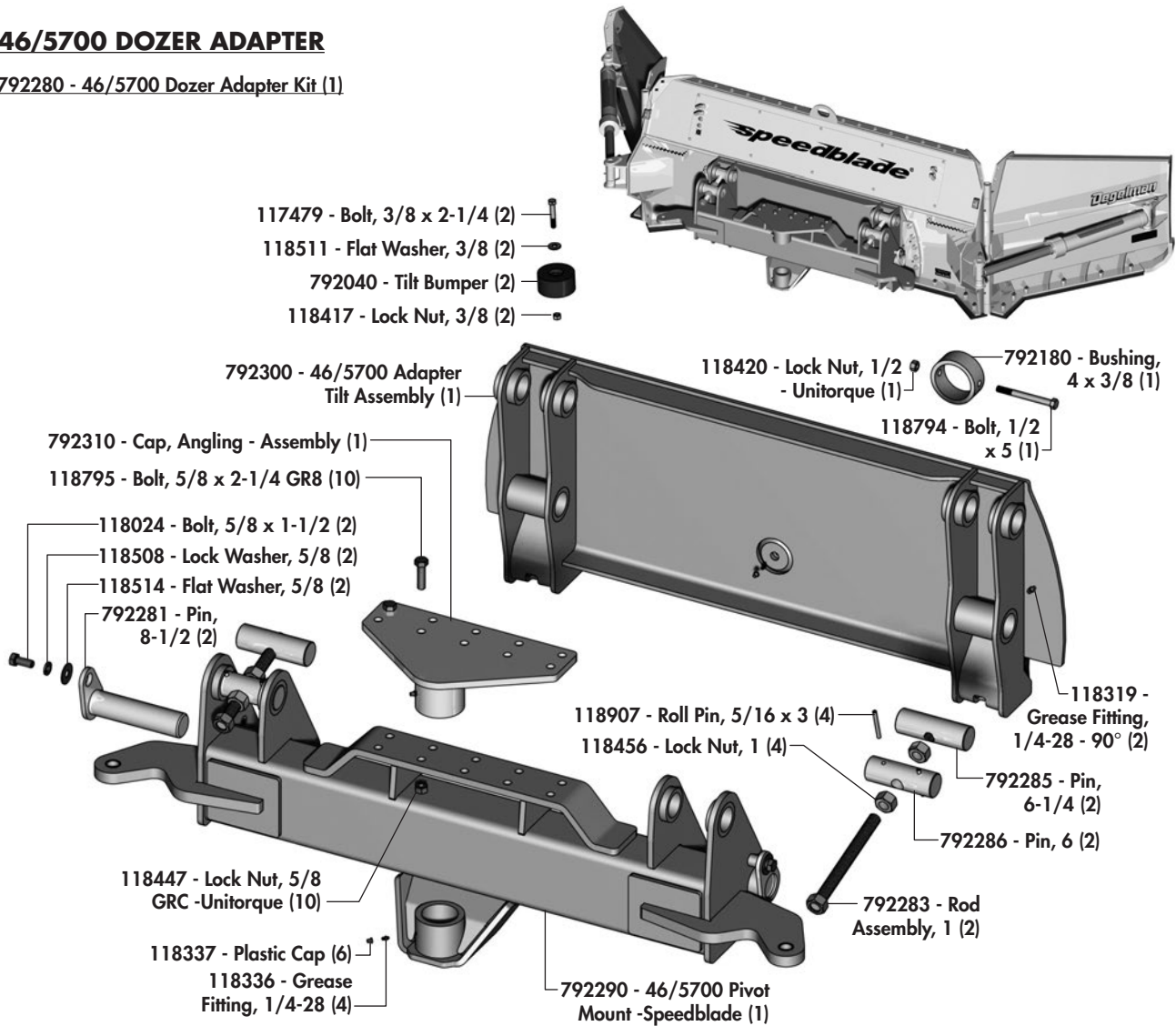

Mounting Options

46/5700 DOZER ADAPTER

792315 - 46/5700 Dozer Mounting Kit (1)

MOUNTING COMPONENTS

Included in this kit are **two - 3" Cylinder Stops** (see below), and **three sets of hoses and fittings** to extend the connections to the rear of the tractor.

Since tractors and routings vary, the customer can select the hose combination(s) that will allow him to safely route and secure the hoses as needed. Also included is a **hose take-up assembly** for the rear of the tractor.

Hydraulic Hoses in Kit

- 258 126080 - Hose, 3/8 x 258 (2)
- 70 126577 - Hose, 3/8 x 70 (2)
- 36 126535 - Hose, 3/8 x 36 (2)

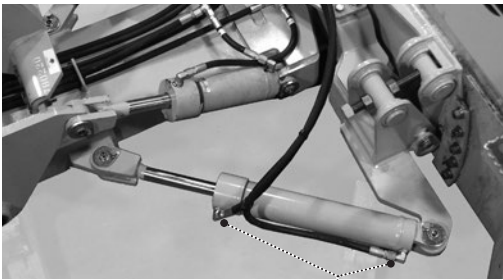

⚠ IMPORTANT: The ports on 46/5700 Angle Cylinders **MUST FACE OUT** for Speedblade installations even if the dozer reference manual shows otherwise.

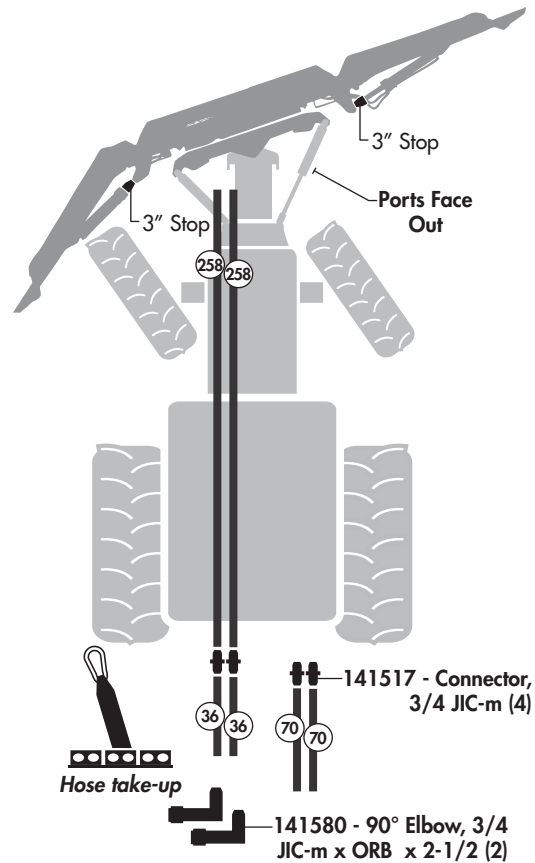

Cylinder Stops

Cylinder stops may be required to prevent Speedblade Wing from contacting tire when both angle cylinder and wing cylinders are fully retracted.

⚠ IMPORTANT:

Ensure proper range of motion is unrestricted before operating.

3" Cylinder stops are included in Speedblade mounting kit.

2" Stops are also available upon request to your dealer.

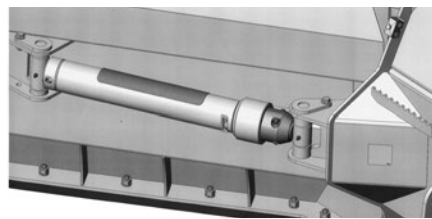

792308 - Cylinder Stop, 3" (2)

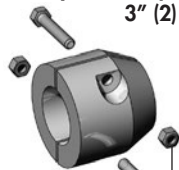

118087 - Bolt, 3/8 x 2 (2)

118417 - Lock Nut, 3/8 (2)

792307 - Cylinder Stop, 2" (2)



118087 - Bolt, 3/8 x 2 (2)

118417 - Lock Nut, 3/8 (2)

Rear Hose Take-Up

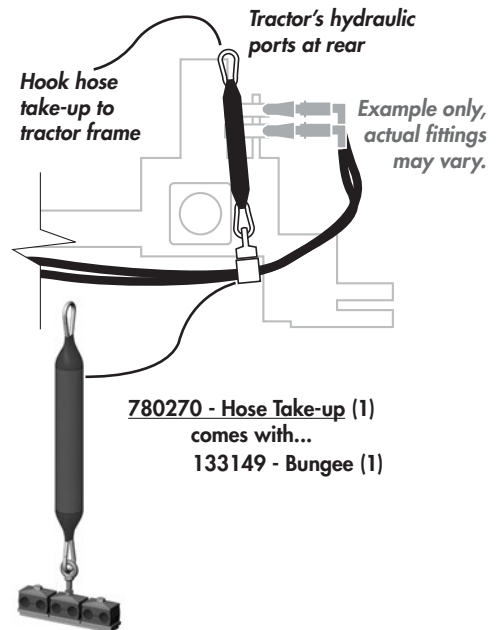

Optional Kits

OPTIONAL 2-LEVER HYDRAULICS OPTION

792215- 2-Lever Hydraulics Kit (1)

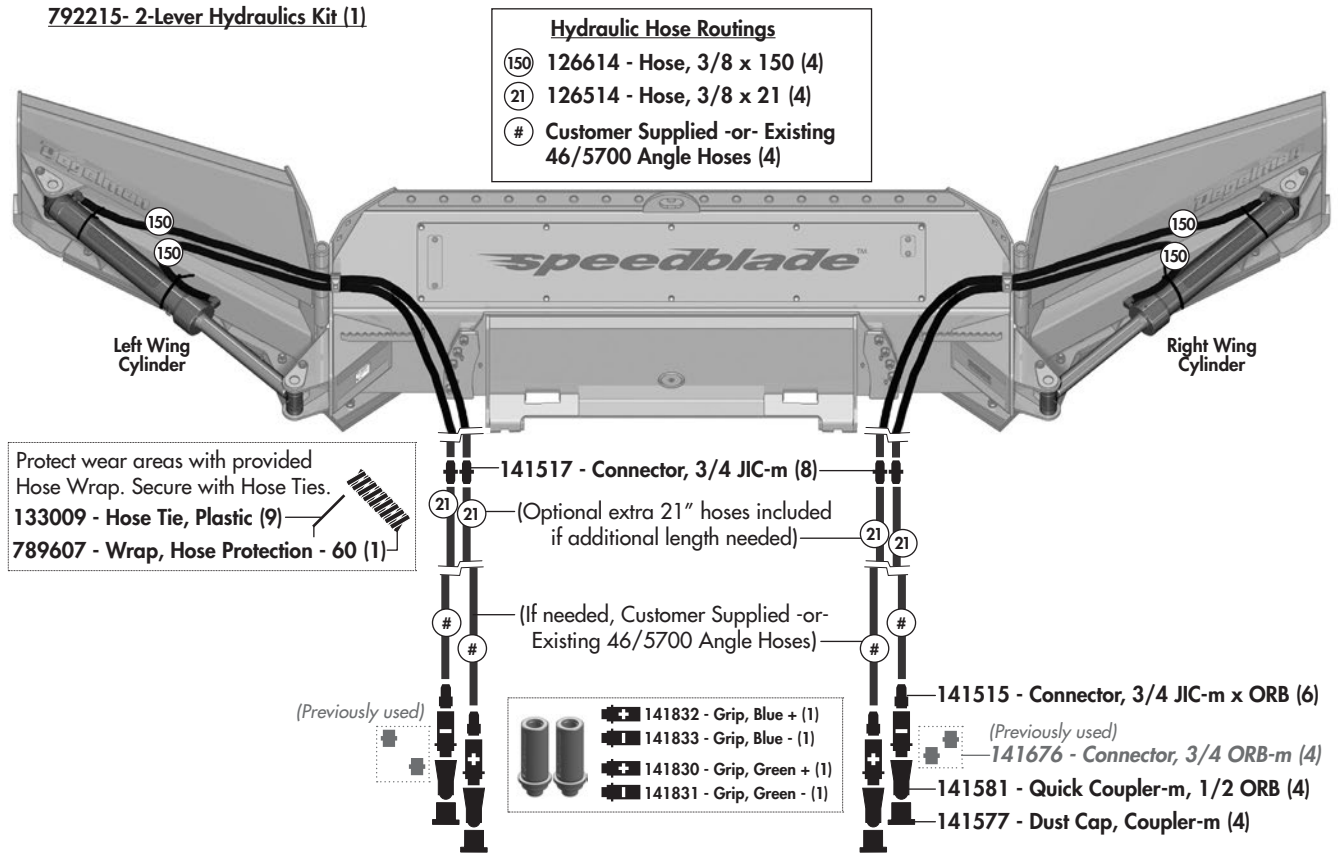

OPTIONAL TILT LOCK KIT

TILT LOCK KIT

By default, the Speedblade comes with rubber suspension bumpers that allow the Speedblade to contour from side-to-side on the ground. However, for some work applications users may prefer to lock out this side-to-side contour motion and prefer the blade to remain level. For these applications, a Tilt Lock Kit is available.

792205- Tilt Lock Kit (1)

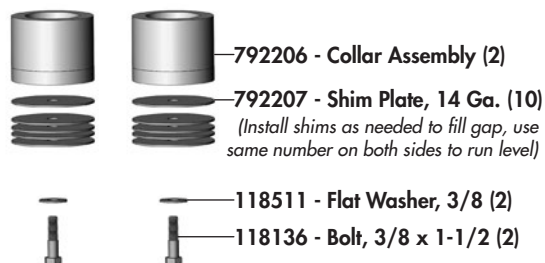

Optional Skid Steer Control

OPTIONAL SKID STEER CONTROL KIT

792231 - Skid Steer Hydraulics Kit (1)

- Hydraulic Hose Routings**
- 56 126683 - Hose, 3/8 x 56 (4)
 - 86 126656 - Hose, 3/8 x 86 (2)
 - # Existing 46/5700 Angle Hoses (2)

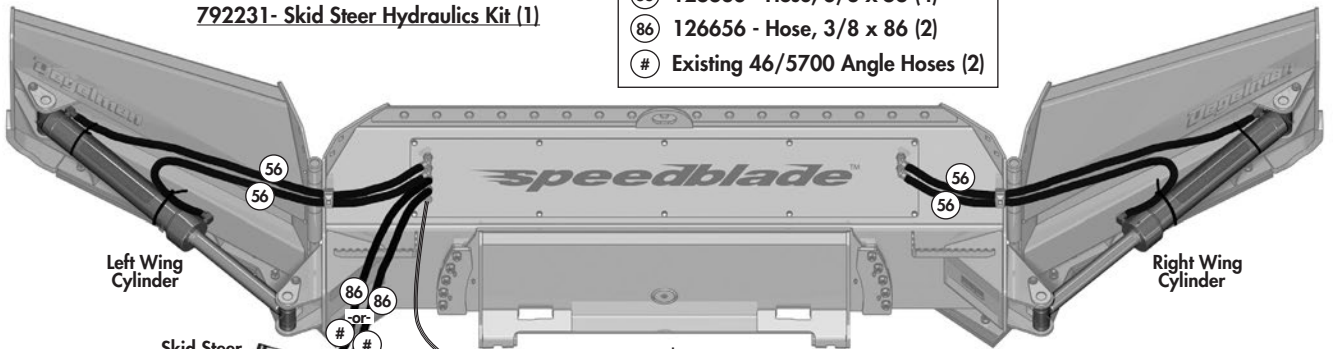

- Tractor Couplers**
- 141577 - Dust Cap Coupler-m (2)
 - 141581 - Quick Coupler-m - 3/4 ORB (2)
 - 141504 - 90° Elbow 3/4 m JIC x ORB (2)

- Skid Steer Couplers**
- 141621 - Coupler Tip, Flat - m x #8 ORB (1)
 - 141623 - Dust Cap, m (1)
 - 141515 - Connector, 3/4 JIC-m x ORB (2)
 - 141624 - Dust Cap, f (1)
 - 141622 - Coupler Tip, Flat - f x #8 ORB (1)

Connect wiring harness to the electrical connector on the LH side of the access panel assembly.

792185 - Wiring Harness Assembly, Outer (1)

NOTE: Ensure hydraulic hoses and electrical wiring are secured away from pinch points.

- 141609 - Orifice Adapter, 3/4 JIC-m x 3/4 JIC-f (1) (Rod end only, both cylinders)
 - 141515 - Nipple, 3/4 JIC-m x ORB (2)
 - 123070 - Cyl, Monarch - 3 x 20 x 2 (1)
- (Previous Cylinder was "123220 - Cylinder, 3 x 20 x 2 and used two "141504 - 90° Elbows, 3/4 JIC-m x ORB" facing each other)

Connect to a 12V power source.

NOTE: Use a 20A in-line fuse.

Solenoid Switch Button. Route into cab and secure to left hand Joystick/Controller.

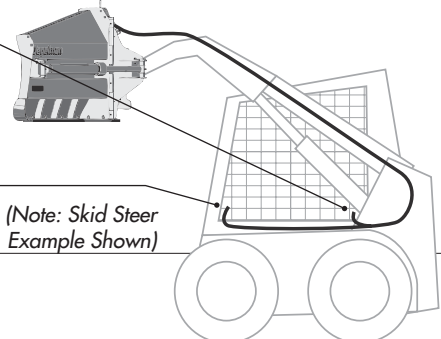

792185 - Wiring Harness Assembly (1)

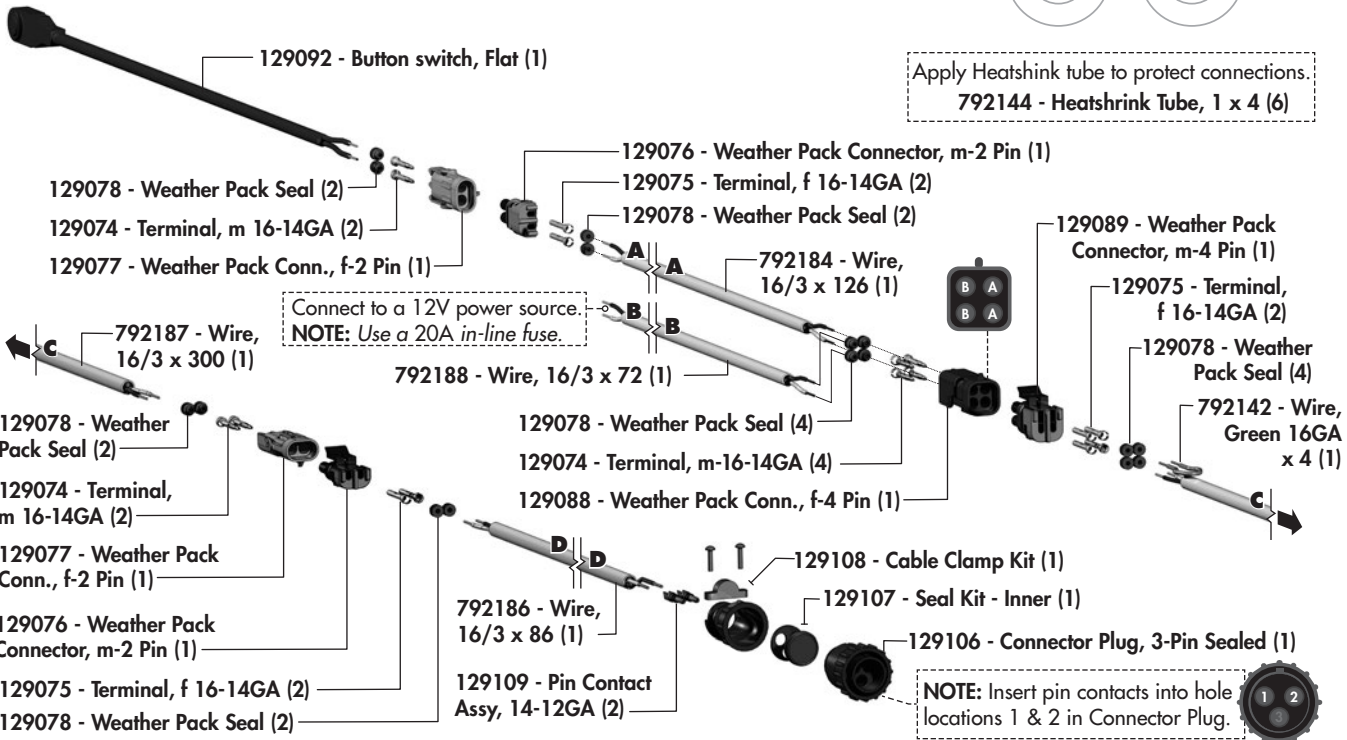

Optional Skid Steer Control

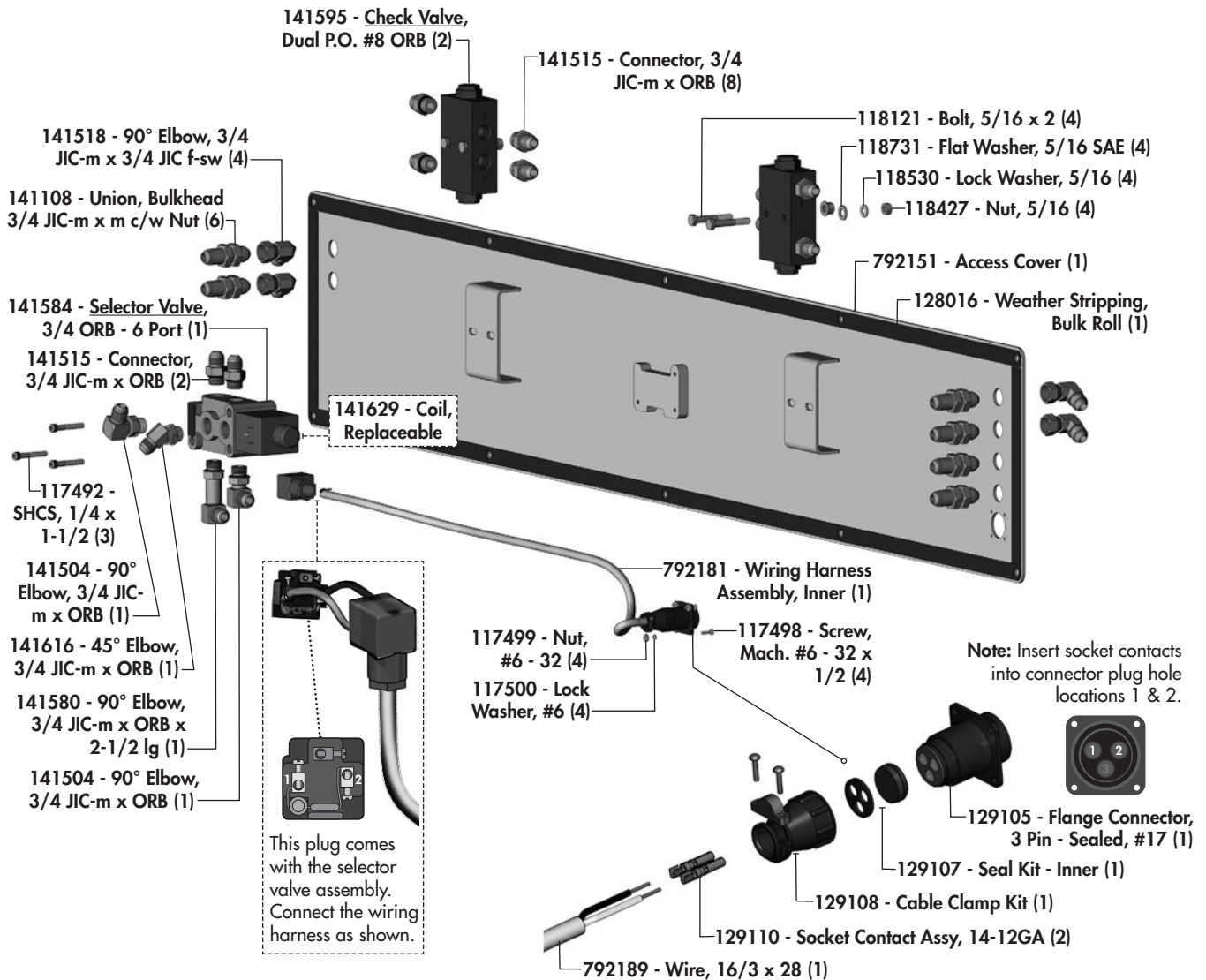
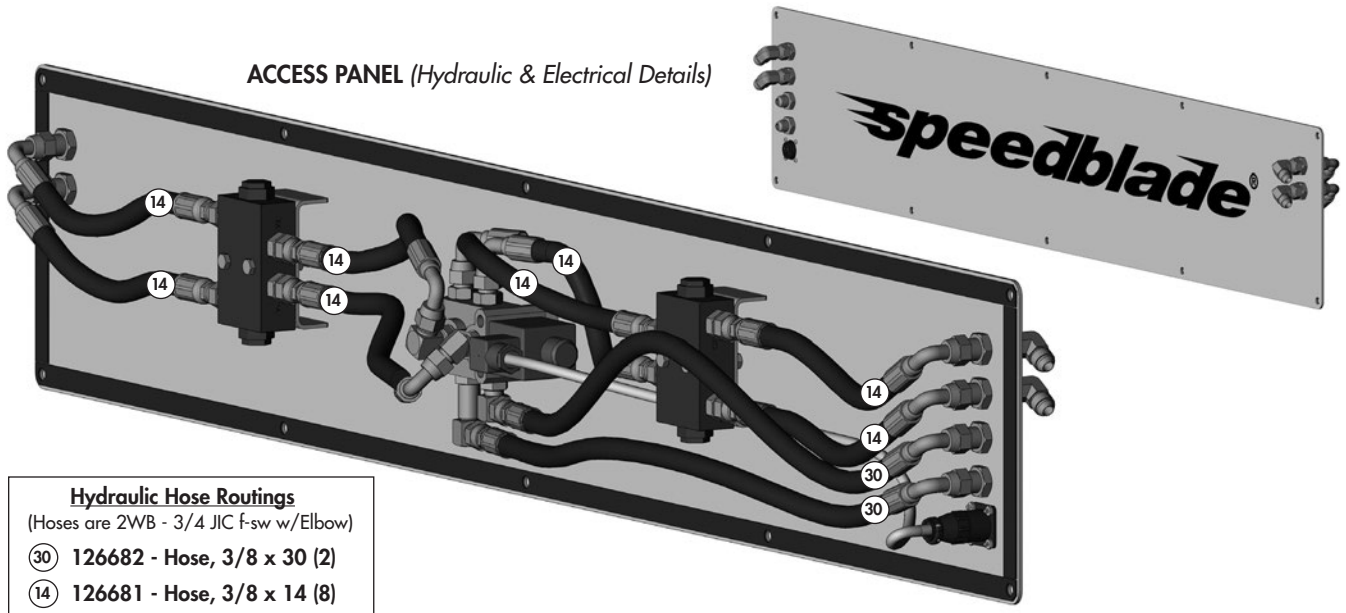

Warranty

2 Year Limited Warranty

Degelman Industries LP ("Degelman") warrants to the original purchaser of any new Degelman equipment, purchased from an authorized Degelman dealer, that the equipment will be free from defects in material and workmanship for a period of two (2) years from the date of delivery, for non-commercial use (including farm, institutional, government, and municipality) and (1) year from the date of delivery for commercial use. The obligation of Degelman to the purchaser under this warranty is limited to the repair or replacement of defective parts in the first year and to the provision, but not the installation of replacement parts in the second year. Degelman reserves the right to inspect any equipment or parts which are claimed to have been defective in material or workmanship.

This warranty limits its replacement or repair coverage to what is consistent with the warranty of Degelman's suppliers of purchased components. Replacement or repair parts installed in the equipment covered by this limited warranty are warranted for ninety (90) days from the date of delivery of such part or the expiration of the applicable new equipment warranty period, whichever ever occurs later. Warranted parts shall be provided at no cost to the user at an authorized Degelman dealer during regular working hours. Warranted replacement parts will either be replaced or rebuilt at Degelman's discretion.

Disclaimer of implied warranties & consequential damages

This warranty shall not be interpreted to render Degelman Industries LP liable for injury, death, property damage or damages of any kind, whether direct, consequential, or contingent to property. Without limiting the generality of the foregoing, Degelman shall not be liable for damages resulting from any cause beyond its reasonable control, including, without limitation, loss of crops, any expense or loss of labour, supplies, rental machinery or loss of use.

No other warranty of any kind whatsoever, express or implied is made with respect to this sale; and all implied warranties of merchantability and fitness for a particular purpose which exceed the obligations set forth in this written warranty are hereby disclaimed and excluded from this sale. This exclusion shall not apply in any jurisdiction where it is not permitted by law.

This limited warranty shall not apply:

1. If, in the sole opinion of Degelman, the unit has been subjected to misapplication, abuse, misuse, negligence, accident or incorrect installation.
2. To any goods that have sustained damage or deterioration attributable to a lack of routine maintenance (eg. Re-torque of mounting hardware.)
3. If parts not made or supplied by Degelman have been used in the connection with the unit, if, in the sole judgement of Degelman such use affects its performance, safety, stability or reliability.
4. If the unit has been altered or repaired outside of an authorized Degelman dealership in a manner which, in the sole judgement of Degelman, affects its performance, safety, stability or reliability.
5. To expendable or wear items such as cutting edges, skid shoes, and any other items that in the company's sole judgement is a wear item.

No employee or representative of Degelman Industries LP is authorized to change this limited warranty in any way or grant any other warranty unless such change is made in writing and signed by the Degelman Service Manager.

This limited warranty is subject to any future availability of supply, which may directly affect Degelman's ability to obtain materials or manufacture replacement parts.

Degelman reserves the right to make improvements in design or changes in specifications at any time, without incurring obligations to owners of equipment previously delivered.

This limited warranty is subject to compliance by the customer to the enclosed *Retail Customer's Responsibility Under Degelman Warranty*.

Make certain the warranty registration card has been forwarded to:

**Degelman Industries LP
Box 830
272 Industrial Dr.
Regina, SK, Canada
S4P 3B1**

