

STRAWMASTER X50

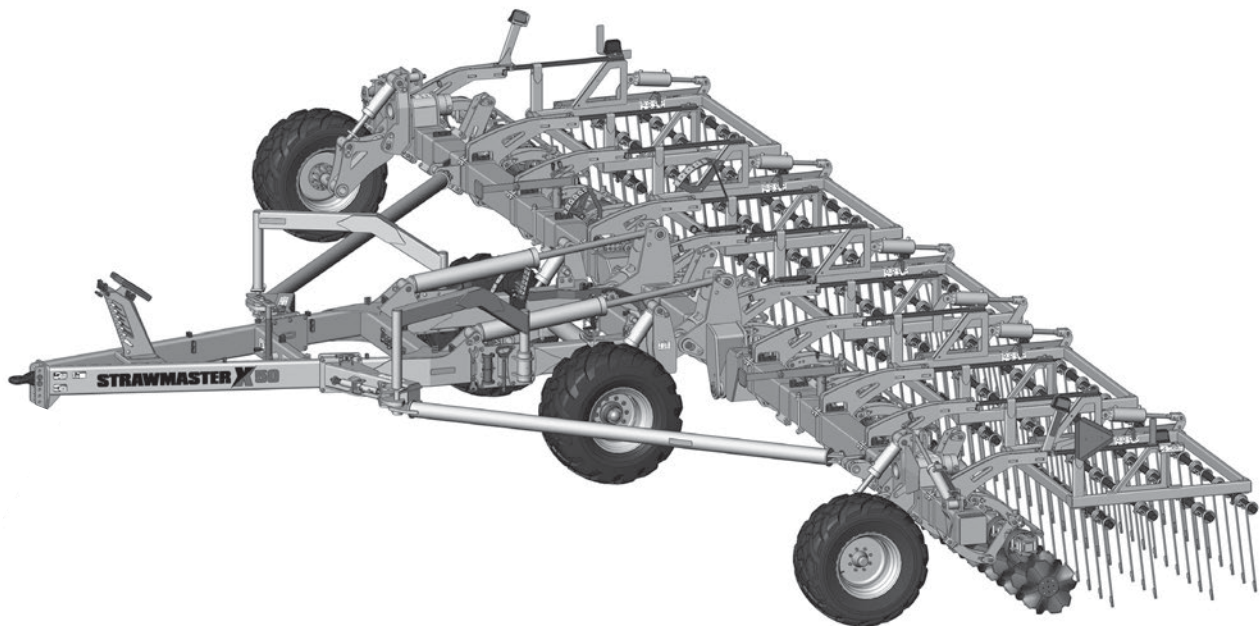

STRAWMASTER X50

143481 v1.0

DEGELMAN INDUSTRIES LP
BOX 830-272 INDUSTRIAL DRIVE,
REGINA, SK, CANADA, S4P 3B1
FAX 306.543.2140 PH 306.543.4447
1.800.667.3545 DEGELMAN.COM

**STRAWMASTER X
50**

QUICK-START GUIDE* for STRAWMASTER X

* Refer to operators manual for complete safety and operation info.



A Connect Hydraulics

- 1 WHEELS..... Wheel Height Cylinders
 - 2 TRANSPORT..... Transport Cylinders
 - 3 DISCS..... Disc Cylinders
 - 4 TINE ANGLE..... Harrow Section Cylinders
 - 5 LATCH & ENDWHEEL..... Latch/Steering Cylinders
- IMPORTANT:** Before working in field, lock the function to avoid accidental operation.
- 6 JACK..... Jack Cylinder

B Backing Into Field Position

Note: Ensure there is plenty of room behind and to the sides of the Strawmaster before backing into field position.

- 1) ENSURE jacks are raised prior to backing up.
- 2) REMOVE transport pins/bars and store.
- 3) SLIGHTLY open the transport wheels. (Only 20°)

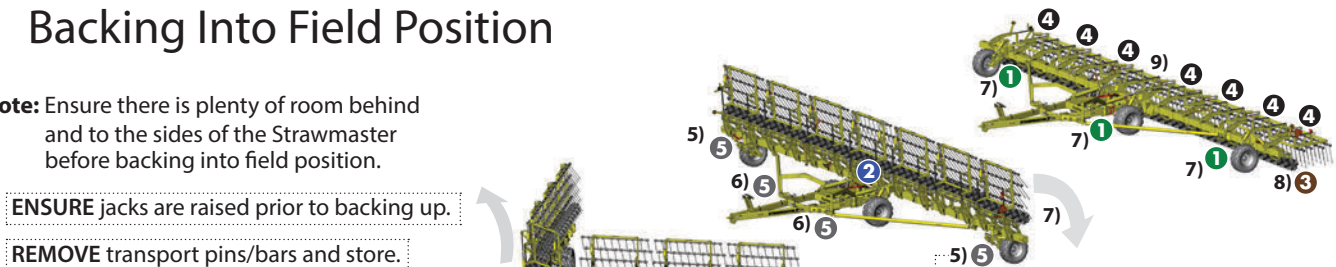

- 4) BACK-UP SLOWLY/EVENLY to avoid serious damage to transport wheels.
- 5) FULLY ROTATE end wheels BEFORE latching truss arm clamps.

- 6) Make sure truss arm LATCHES ARE FULLY ENGAGED before lowering harrow sections into field position.
- 7) When lowering harrow sections, keep TRAILER HEIGHT AT MAXIMUM.
- 8) Lower disc sections.

- 1) Raise hydraulic jack after connecting to the tractor.
- 2) Remove the front Center Beam Transport Pins, Cylinder Lock Bars, and Endwheel Transport Bars and place in storage locations.

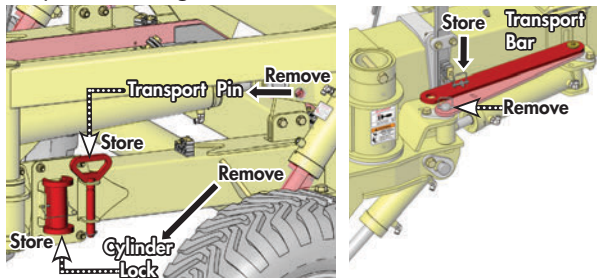

- 3) Activate the steering cylinders to slightly angle open the transport wheels, but no more than 20°.

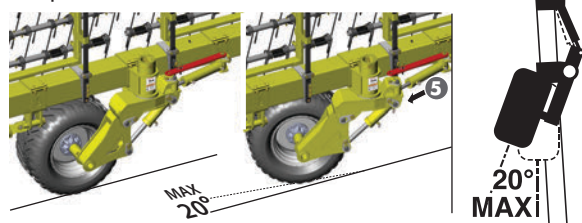

- 4) Back-up slowly. The wings will open up. Ensure there is lots of room behind and to the sides. Back-up evenly so you don't damage the transport wheels.

IMPORTANT: Be sure to back-up evenly to avoid serious damage to the transport wheels.

- 5) As wings are almost fully opened, FULLY ROTATE the end wheels into field position BEFORE completely open.

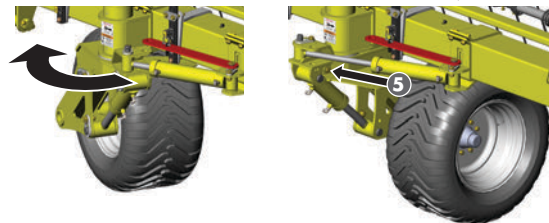

- 6) Activate the LATCH hydraulics to fully secure the truss arms into place. Make sure truss arm LATCHES ARE FULLY ENGAGED before lowering harrow sections into field position.

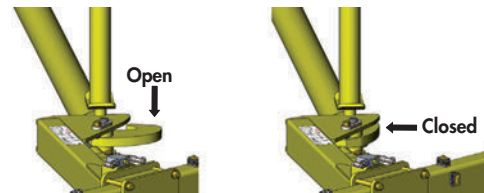

IMPORTANT: To prevent serious damage, ensure both latches have fully engaged and then LOCK-OUT the Latch & Endwheel circuit before operating.

- 7) Ensure the TRAILER HEIGHT is raised to MAXIMUM and then lower the harrow sections into field position using the Transport Cylinders.
- 8) Lower the disc sections using the Disc Cylinders.
- 9) Adjust Tine Angle, Trailer Height and Disc settings.

C Setting Tine Angle, Pressure, Frame, & Disc Angle

Tine Angle Adjustment

There are no standard angles for running the tines, the operator may adjust the tine angles as needed to achieve desired results.

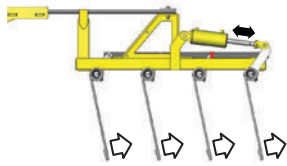

- Retract rephasing tine angle cylinders ④ to raise tines.
- Extend cylinders to lower.

Note: Actual settings will vary with tine wear. Ensure trailer and frame are leveled properly. (Refer to Height Adjustment)

IMPORTANT: Re-synchronize the tine section cylinders by fully extending the rephasing cylinders and holding for 30 seconds. This should be repeated a few times daily or as needed, especially in hilly conditions. - Refer to manual for more information. -

Tine Angle Indicator

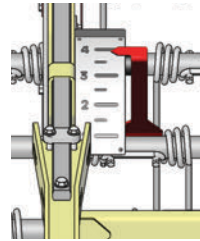

- 4 } Chemical Incorporation or Light Tillage
- 3 } Harrowing in wet conditions or Discing in Sloughs
- 2 } Harrowing in wet conditions or Discing in Sloughs
- 1 } Discing in Sloughs

Trailer & Wing Beam Height Adjustment

After Tine Angle Adjustment is complete, adjust wheel height until trailer frame is parallel to the ground. If needed, clevis height may be adjusted.

When set level with harrows...



Front & back tines **apply equal** pressure

When set higher...



Front tines **apply less** pressure

When set lower...



Front tines **applying more** pressure

Center Beam Torque Adjustment

Beam Torque Indicator

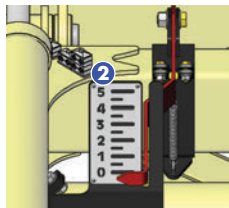

- 5 Maximum Pressure
- 4 (Light Tillage)
- 3 Normal Harrowing
- 2
- 1 Minimum Pressure
- 0 (Spread Chaff & Residue)

NOTE: The applied beam torque shown on the indicator is adjusted by applying (+) or reducing (-) pressure with the Transport Cylinders. ②

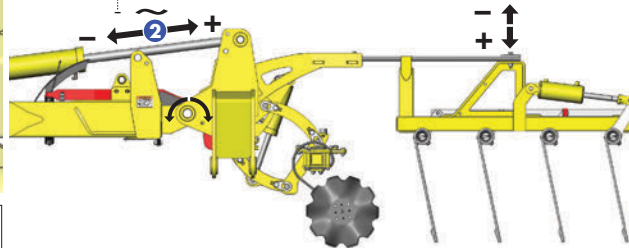

Setting Disc Angle

- Loosen Jam Nuts.
- Adjust Turnbuckle.
- Re-tighten Jam Nuts.

(Each disc section is adjusted independently.)

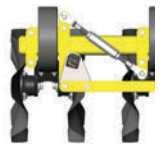

Disc Angle Indicator

0°-4° with a coultter disc will allow you to open the ground and cut trash with minimal soil disruption.

5°-7° is good for mixing some dirt with residue while loosening the soil but still leave stubble standing to catch snow.

8°-10° is perfect for working low spots with high trash and for drying them out.

Trailer Height Indicator

Adjust "Wheel Height Cylinders". ①



- 5 } Adjust
- 4 } According to
- 3 } Tine Angle
- 2 } Setting
- 1 } Setting
- 0 - Transport

NOTE: "0" indicates fully raised & "5" is lowest height.

Disc Depth Indicator

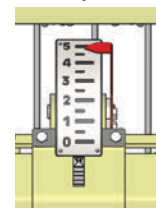

- 5 } Adjust
- 4 } according
- 3 } to Cart
- 2 } Height &
- 1 } Disc Depth
- 0 } required.
- 0 - Transport

(For minimal tillage, use in float.)

Remember When Operating:

- Straw should be dry.
- A speed of 8 to 12 MPH (12 to 16 KPH) is suggested to efficiently shatter and spread straw and residue.
- Tight turns are **not recommended** with the discs engaged. If you are not lifting discs on headland turns, skip every 2nd pass.

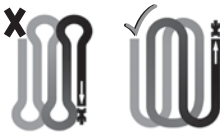

- If discing aggressively, **DO NOT** have much straw in harrow sections.

- If machine leaves small clumps of straw, apply slight down pressure by extending Transport cylinders.
- If machine leaves large clumps of straw, reduce down pressure by retracting the Transport cylinders and reducing the tine angle.

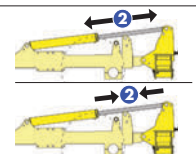

Maintenance

(Check Machine Daily)

- Check for missing, worn or damaged parts
- Grease Endwheel Turrets & Truss Ball Joints (25 hrs)
- Working points & pins
- Hubs & Spindles
- Hydraulic Connections & Hoses
- Tire Pressure: 41 PSI (283 kPa)

* Refer to operators manual for complete safety and operation info.

D Moving Into Transport Position

- 1) When placing machine into Transport position, keep the Trailer Height at Maximum. ①
- 2) Raise disc sections. ③ **IMPORTANT:** Discs **MUST** be raised. Failure to do so will result in damage to disc sections.
- 3) Operate the transport hydraulics ② to fully raise the harrow sections.
- 4) Fully Rotate the endwheels ⑤ before driving forward. The wing beams should fold back into transport position.
- 5) Install all frame transport pins (2), cylinder lock bars (2), and endwheel transport bars (2).

IMPORTANT: Endwheel transport bars **MUST** be installed during transport.

- 6) Ensure SMV sign and reflectors are clean and lights are working. Follow all local transport laws when transporting.

STRAWMASTER X

* Reference Sheet Quick-Start Guide

OPERATORS SECTION - TABLE OF CONTENTS

Introduction	1
Safety	2
Operation	4
Pre-Operation Checklist	5
Hook-Up	6
Transport to Field Position	7
Indicator Overview	8
Tine Angle Settings	9
Disc Angle Settings	10
Rephasing Cylinder Adjustments	11
Service & Maintenance	12
Maintenance Checklist & Specifications	12
Repair - Hydraulic Cylinder Repair	15
Repair - Pressed Bushing	16
Repair - Wheel Hub	17
Repair - Tine Replacement	18
Troubleshooting	19

PARTS SECTION - TABLE OF CONTENTS

Warranty	47
-----------------	-----------

Maintenance Free Pins & Bushings

 **IMPORTANT: INSTALL DRY** 

Do NOT use any oil/grease/lubricant on pin or bushing surfaces when installing the maintenance free pins into composite bushings.

Introduction

STRAWMASTER X50

CONGRATULATIONS on your choice of a Degelman Strawmaster X to complement your farming operation. It has been designed and manufactured to size residue while leaving standing material and allows more tillage than a heavy harrow but less than a high speed disc. Use this manual as your first source of information about this machine.

TO THE NEW OPERATOR OR OWNER - Safe, efficient and trouble free operation of your Degelman Strawmaster X requires that you and anyone else who will be operating or maintaining it, read and understand the Safety, Operation, Maintenance and Troubleshooting information contained within this manual.

By following the operating instructions in conjunction with a good maintenance program your machine will provide many years of trouble-free service. Keep this manual handy for frequent reference and to pass on to new operators or owners. Call your Degelman Dealer if you need assistance, information, or additional copies of the manual.

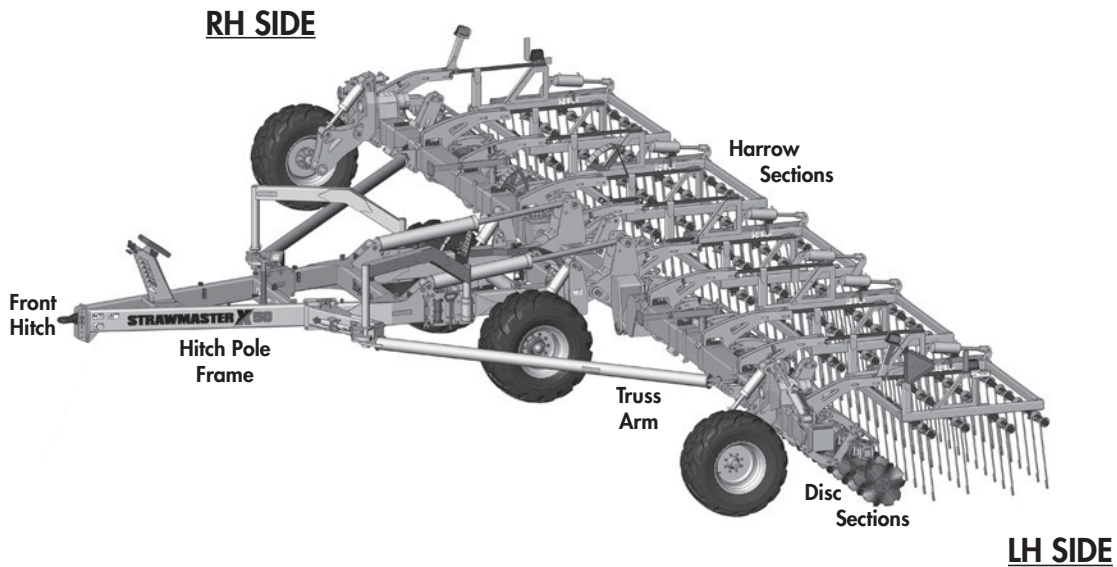

OPERATOR ORIENTATION - The directions left, right, front and rear, as mentioned throughout the manual, are as seen from the tractor drivers' seat and facing in the direction of travel.

Why is **SAFETY** important to **YOU**?

3 **BIG** Reasons:

- **Accidents Can Disable and Kill**
- **Accidents Are Costly**
- **Accidents Can Be Avoided**



SAFETY ALERT SYMBOL

The **Safety Alert Symbol** identifies important safety messages applied to the Strawmaster and in this manual. When you see this symbol, be alert to the possibility of **injury or death**. Follow the instructions provided on the safety messages.

The **Safety Alert Symbol** means:

ATTENTION!
BECOME ALERT!
YOUR SAFETY IS INVOLVED!

SIGNAL WORDS

Note the use of the Signal Words: **DANGER**, **WARNING**, and **CAUTION** with the safety messages. The appropriate Signal Word has been selected using the following guidelines:



DANGER: Indicates an imminently hazardous situation that, if not avoided, **WILL** result in death or serious injury if proper precautions are not taken.



WARNING: Indicates a potentially hazardous situation that, if not avoided, **COULD** result in death or serious injury if proper precautions are not taken.



CAUTION: Indicates a potentially hazardous situation that, if not avoided, **MAY** result in minor or moderate injury if proper practices are not taken, or, serves as a reminder to follow appropriate safety practices.

Safety

SAFETY

YOU are responsible for the safe operation and maintenance of your equipment.

YOU must ensure that you and anyone else who is going to operate, maintain or work around the equipment be familiar with the operating and maintenance procedures and related **safety** information contained in this manual.

Remember, **YOU** are the key to safety. Good safety practices not only protect you but also the people around you. Make these practices a working part of your safety program. Be certain that **EVERYONE** operating this equipment is familiar with the recommended operating and maintenance procedures and follows all the **safety** precautions.

Most accidents can be prevented. Do not risk injury or death by ignoring good safety practices.

- Equipment owners must give operating instructions to operators or employees before allowing them to operate the equipment, and at least annually thereafter per OSHA regulation 1928.51.
- The most important safety device on this equipment is a **SAFE** operator. It is the operator's responsibility to read and understand ALL Safety and Operating instructions in the manual and to follow these. All accidents can be avoided.
- A person who has not read and understood all operating and safety instructions is not qualified to operate the machine. An untrained operator exposes himself and bystanders to possible serious injury or death.
- Do not modify the equipment in any way. Unauthorized modification may impair the function and/or safety and could affect the life of the equipment.
- Think **Safety!** Work **Safely!**

GENERAL SAFETY



1. Read and understand the Operator's Manual and all safety signs before operating, maintaining or adjusting. 

2. Install and properly secure all shields and guards before operating. Use hitch pin with a mechanical locking device.

3. Have a first-aid kit available for use should the need arise and know how to use it. 

4. Have a fire extinguisher available for use should the need arise and know how to use it. 

5. Wear appropriate protective gear. This list includes but is not limited to:

- A hard hat
- Protective shoes with slip resistant soles
- Protective glasses or goggles 
- Heavy gloves 
- Wet weather gear
- Hearing protection
- Respirator or filter mask

6. Clear the area of people, especially small children, and remove foreign objects from the machine before starting and operating.

7. Do not allow riders.

8. Stop tractor engine, set park brake, remove ignition key and wait for all moving parts to stop before servicing, adjusting, repairing or unplugging.

9. Review safety related items with all operators annually.

Operation

TO THE NEW OPERATOR OR OWNER

The Degelman Strawmaster X is designed for sizing residue while leaving standing material and allows for more tillage than a heavy harrow but less than a high speed disc.

The Strawmaster X is fully adjustable with hydraulic tine angle & operating height, and disc angle adjustment with the use of link bars. The disc sections can also operate in a float position or under a variable amount of pressure with the use of hydraulics or for years with less trash/residue, it may be used without discs like a standard heavy harrow.

It is the responsibility of the owner or operator to read this manual carefully to learn how to operate the machine safely, and how to set it to provide maximum efficiency. Safety is everyone's business. By following safe operating practices, a safe environment is provided for the operator and bystanders.

The manual will take you step-by-step through your working day. By following the operating instructions in conjunction with a good maintenance program your machine will provide many years of trouble-free service.

Field Position

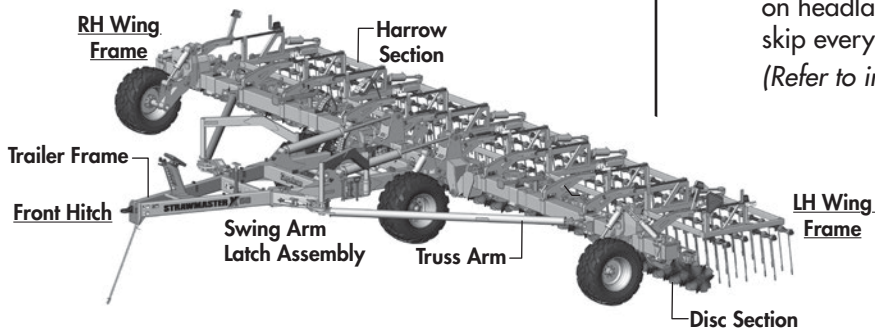

Transport Position



BRIEF OVERVIEW OF OPERATION

- Operating speed will depend on tractor horsepower, environmental conditions and each particular operation. A speed of 8 to 12 MPH. (12 to 16 KPH) is suggested for disc operation and to efficiently shatter/spread straw & residue.
- Operating height for the harrow will vary with the length of the tines, and the angle that the tines are set at.
- The disc sections can be used with pressure from hydraulics or set in float position, where the discs cut the ground under their own weight.
- Tine pressure can be applied using hydraulics to rotate the beam further back. The spring bars will deflect to apply pressure to the harrow section and the ground. The amount of pressure to apply will depend on the application, and the operator's preference.
- Some suggested settings can be found in the "Suggested Tine Angle Settings" and "Suggested Disc Angle" sections. As there are only a few standard guidelines, feel free to experiment with trailer frame height, tine angle & section pressure to obtain desired results for each operation.
- Tight turns are **not recommended** with the discs engaged. If you are not lifting discs on headland turns, skip every 2nd pass. (Refer to image.)

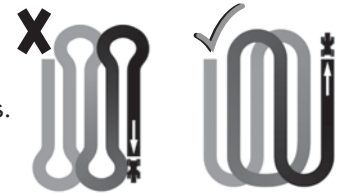
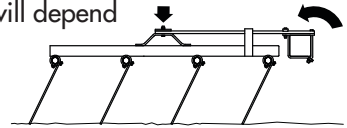

PRINCIPLES OF OPERATION

The Strawmaster X harrow sections consist of four rows of 30" tines. These allow material to move through the harrows. As the tines drag along the ground, they oscillate to build up a high frequency vibration and provide a shattering action which breaks up the straw allowing the residue to be spread evenly as it is released. The disc sections will cut residue and move some dirt depending on how they are set.

Operation

BREAK-IN

Although there are no operational restrictions on the Strawmaster X when it is new, there are some mechanical checks that must be done to ensure the long term integrity of the unit. When using the machine for the first time, follow this procedure:

⚠ IMPORTANT: *It is important to follow the Break-In procedures especially those listed in the "Before using" section below to avoid damage:*

A. Before using:

1. Read Safety Info. & Operator's Manual.
2. Complete steps in "Pre-Operation Checklist".
3. Lubricate all grease points.
4. Check all bolt tightness.

B. After operating for 2 hours:

1. Check all hardware. Tighten as required.
2. Check all hydraulic system connections. Tighten if any are leaking.

C. After operating for 8 hours:

1. Repeat Step B.
2. Re-torque all bolts on harrow sections and mounting brackets.
3. Go to the service schedule as outlined in the "Service & Maintenance" section.

⚠ OPERATING/MAINTENANCE SAFETY

- Read and understand the Operator's Manual before starting.
- Lower to ground, stop engine, place all controls in neutral, set park brake and remove ignition key before servicing, adjusting or repairing.
- Keep hands, feet, hair and clothing away from all moving and/or rotating parts.
- Be careful when working around or maintaining a high pressure hydraulic system. Wear the proper hand and eye protection when searching for a pin hole leak in a hose or fitting.
- Place safety stands or large blocks under the frame before removing the tires or working beneath the machine.
- Do not allow riders.
- Clear the area of all bystanders, especially children.
- Stay well back from machine when operating. Keep others away.

PRE-OPERATION CHECKLIST

It is important for both personal safety and maintaining the good mechanical condition of the machine that this pre-operational checklist be followed.

Before operating the machine and each time thereafter, the following areas should be checked off: 

- Lubricate the machine per the schedule outlined in the "Maintenance Schedule".
- Use only a tractor with adequate power to pull the Strawmaster X under ordinary operating conditions:
Minimum HP
50' model: **375 HP**
- Ensure the Hitch Clevis is set at the correct height for the tractor drawbar and trailer height.
- Ensure that the machine is properly attached to the tractor using a drawbar pin with provisions for a mechanical retainer. Make sure that a retainer such as a Klik pin is installed.

NOTE: *It is important to pin the draw bar in the central location only.*

- Check tires and ensure that they are inflated to the specified pressure. **(41 PSI/283 kPa)**
- Ensure that a safety chain on the hitch is installed.
- Check oil level in the tractor hydraulic reservoir. Top up as required.
- Check all bolt tightness.
- Inspect all hydraulic lines, hoses, fittings and couplers for tightness. Tighten if there are leaks. Use a clean cloth to wipe any accumulated dirt from the couplers before connecting to the tractor's hydraulic system.
- Check all the machine settings, refer to the Adjustment sections. Perform adjustments as necessary.
- Check tines, remove entangled debris. Replace damaged tines. If tines are 20 in. or less in length, they should be replaced. (New tine length: 26/30 in.)
- Check disc wear.

Operation

HOOK-UP / UNHOOKING

The Strawmaster X should always be parked on a level, dry area that is free of debris and foreign objects. Follow this procedure to hook-up:

1. Clear the area of bystanders and remove foreign objects from the machine and working area.
2. Make sure there is enough room to back the tractor up to the trailer hitch.
3. Start the tractor and slowly back it up to the hitch point.
4. Stop the tractor engine, place all controls in neutral, set park brake and remove ignition key before dismounting.
5. Use the trailer jack to raise or lower the hitch to align with the drawbar.
6. Install a drawbar pin with provisions for a mechanical retainer such as a KLIK pin. Install the retainer.
7. Install a safety chain between the tractor and the hitch.
8. Connect the hydraulics. When connecting:
 - Use a clean cloth or paper towel to clean the couplers on the ends of the hoses. Also clean the area around the couplers on the tractor. Remove the plastic plugs from the couplers and insert the male ends.
 - Be sure to match the pressure and return line to one valve bank.
9. Raise the Front Hitch Jack and rotate it 90° to place into stowed position.
10. Raise the two Wing Jacks and rotate 90° to place into stowed position.
11. Raise Hydraulic Jack.
12. When unhooking from the tractor, reverse the above procedure.

⚠ DANGER/WARNING: NEVER disconnect the Strawmaster from the tractor without both **Wing Jacks** being and **Hydraulic Jack** lowered and engaged with the ground.



⚠ TRANSPORT SAFETY

1. Check with local authorities regarding machine transport on public roads. Obey all applicable laws and regulations.
2. Always travel at a safe speed. Use caution when making corners or meeting traffic.
3. Maximum Recommended Transport Speed: 50 km/h or 30 mph - Road Conditions (Field speeds may be lower.)
4. Make sure the SMV (Slow Moving Vehicle) emblem and all lights and reflectors required by the local highway and transport authorities are in place, are clean and can be seen clearly by all overtaking and oncoming traffic.
5. Keep to the right and yield the right-of-way to allow faster traffic to pass. Drive on the road shoulder, if permitted by law.
6. Always use hazard warning flashers on tractor when transporting unless prohibited by law.
7. Always use a pin with provisions for a mechanical retainer and a safety chain when attaching to a tractor or towing vehicle.

⚠ IMPORTANT: Under no circumstances should there ever be riders while the Strawmaster is in motion or transport. **NO RIDERS!**

FIELD TO TRANSPORT POSITION

1. When placing machine into Transport position:
 - Keep the **Trailer Height at Maximum**
 - **FULLY RAISE Disc Sections**
2. Operate the transport hydraulics to fully raise the harrow sections.
3. **Fully Rotate** the endwheels before driving forward. The wing beams should fold back into transport position.
4. Install all frame transport pins (2), cylinder lock bars (2), and endwheel bars (2).
5. Check wing jacks and *ensure the jacks and winding handles are clear of the truss arm.*
6. Ensure SMV sign and reflectors are clean and lights are working. Follow all local transport laws when transporting.

⚠ IMPORTANT: Endwheel transport bars **MUST** be installed during transport.

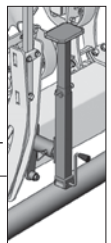

Operation

TRANSPORT TO FIELD POSITION

Note: Ensure there is plenty of room behind and to the sides of the Strawmaster before backing into field position.

- 1) ENSURE jacks are raised prior to backing up.
- 2) REMOVE transport pins/bars and store.



3) SLIGHTLY open the transport wheels. (Only 20°)

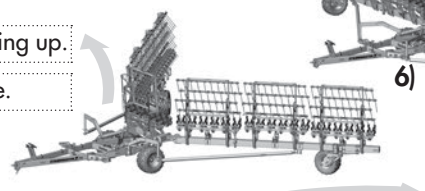

4) BACK-UP SLOWLY/EVENLY to avoid serious damage to transport wheels.

5) FULLY ROTATE end wheels BEFORE latching truss arm clamps.

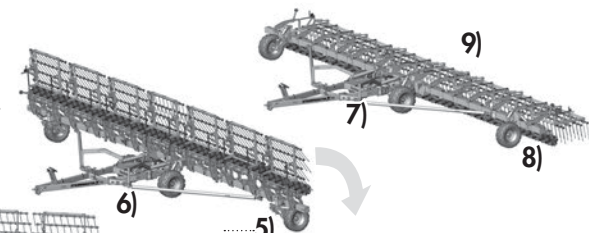

6) Make sure truss arm LATCHES ARE FULLY ENGAGED before lowering harrow sections into field position.

7) When lowering harrow sections, keep the TRAILER HEIGHT AT MAXIMUM.

8) Lower disc sections.

1. Raise hydraulic jack after connecting to the tractor.

2. Remove the front **Center Beam Transport Pins (2)**, **Cylinder Lock Bars (2)**, and **Endwheel Transport Bars (2)** and place in storage locations.

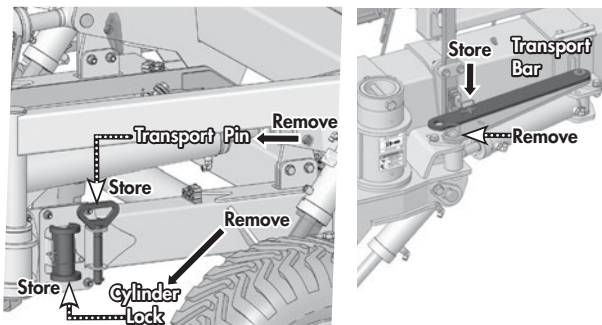

3. Activate the steering cylinders to slightly angle open the transport wheels, but **no more than 20°**.

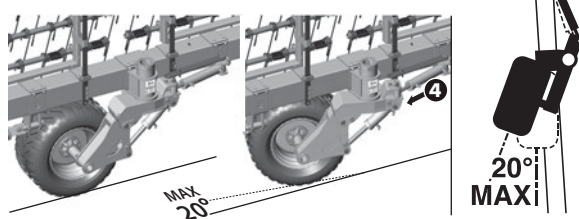

4. Back-up slowly. The wings will open up. Ensure there is lots of room behind and to the sides. Back-up evenly so you don't damage the transport wheels.

IMPORTANT: Be sure to back-up evenly to avoid serious damage to the transport wheels.

5. As wings are almost fully opened, **FULLY ROTATE** the end wheels into field position **BEFORE** completely open.

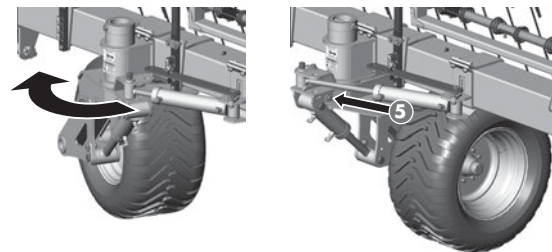

6. Activate the **LATCH** hydraulics to fully secure the truss arms into place. Make sure truss arm **LATCHES ARE FULLY ENGAGED** before lowering harrow sections into field position.

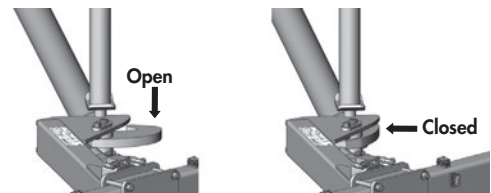

IMPORTANT: To prevent serious damage, ensure both latches have fully engaged and then **LOCK-OUT** the **Latch & Endwheel** circuit before operating.



7. Ensure the **TRAILER HEIGHT** is raised to **MAXIMUM** and then lower the harrow sections into field position using the Transport Cylinders.

8. Lower the disc sections using the Disc Cylinders.

9. Adjust Tine Angle, Trailer Height and Disc Settings.

Operation - Indicator Overview

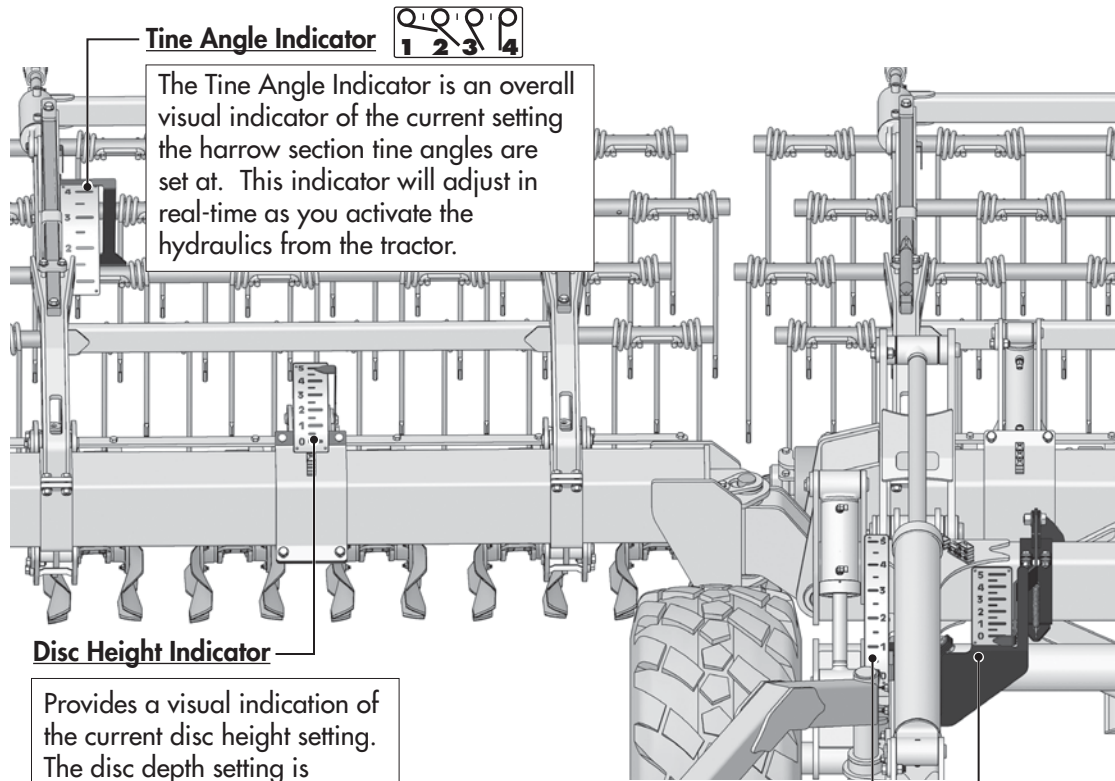

Tine Angle Indicator



The Tine Angle Indicator is an overall visual indicator of the current setting the harrow section tine angles are set at. This indicator will adjust in real-time as you activate the hydraulics from the tractor.

Disc Height Indicator

Provides a visual indication of the current disc height setting. The disc depth setting is adjusted according to the Tine Angle & Trailer/Beam Height.

NOTE: For minimal tillage, place the disc depth circuit in float.

⚠ IMPORTANT: LOCK-OUT Latch & Endwheel Circuit before operating. **5** →

Trailer Height Indicator

Provides a visual indication of the current trailer cart/wing beam height setting. This is adjusted with the "Wheel Height Cylinders".

NOTE: The trailer height indicator reads "0" when fully raised and "5" at the lowest height.

Center Beam Torque Indicator

Shows the amount of "Beam Torque" currently being applied to the center beam by extending or retracting the "Transport Cylinders". A setting of "0" is applying the minimum amount of center beam torque and a setting of "5" is applying the maximum.

CENTER BEAM TORQUE ADJUSTMENT

NOTE: The applied beam torque shown on the indicator is adjusted by applying (+) or reducing (-) pressure with the Transport Cylinders. **2**

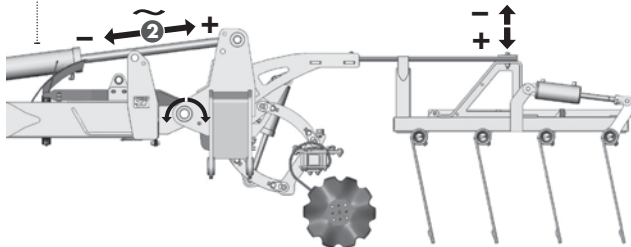

BEAM TORQUE INDICATOR

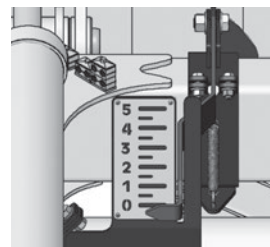

- 5 Maximum Pressure**
- 4 (Light Tillage)**
- 3**
- 2 Normal Harrowing**
- 1 Minimum Pressure**
- 0 (Spread Chaff & Residue)**

⚠ REMEMBER WHEN OPERATING:

- Straw should be dry.
- A speed of 8 to 12 MPH (12 to 16 KPH) is suggested to efficiently shatter and spread straw and residue.
- If discing aggressively, DO NOT have much straw in harrow sections.

- If machine leaves small clumps of straw, apply slight down pressure by extending Transport cylinders.
- If machine leaves large clumps of straw, reduce down pressure by retracting the Transport cylinders and reducing the tine angle.

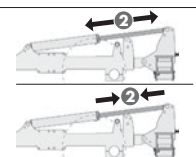

Operation - Tine Angle Settings

TINE ANGLE ADJUSTMENT

Strawmaster X has **Hydraulic** Tine Adjustment. Tine angle adjustment should be made with the machine in field position.

There are no *standard* angles for running the tines, the operator may adjust the tine angles as needed to achieve desired results.

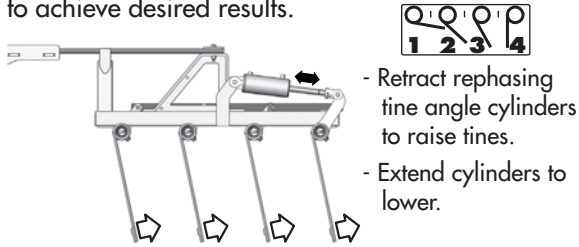

- Retract rephasing tine angle cylinders to raise tines.
- Extend cylinders to lower.

Note: Actual settings will vary with tine wear. Ensure trailer and frame are leveled properly. (Refer to Height Adjustment)

⚠ IMPORTANT: Re-synchronize the tine section cylinders by fully extending the rephasing cylinders and holding for 30 seconds. This should be repeated a few times daily or as needed, especially in hilly conditions. Refer to manual section for more information.

TINE ANGLE INDICATOR

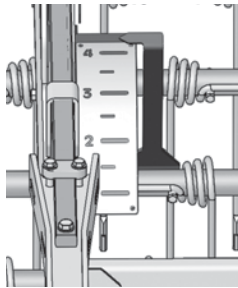

- 4 } Chemical Incorporation or Light Tillage
- 3 }
- 2 } Harrowing in wet conditions or Discing in Sloughs
- 1 }

TRAILER & WING BEAM HEIGHT ADJUSTMENT

After Tine Angle Adjustment is complete, adjust wheel height until the cart/trailer frame is parallel to the ground. If needed, clevis height may be adjusted.

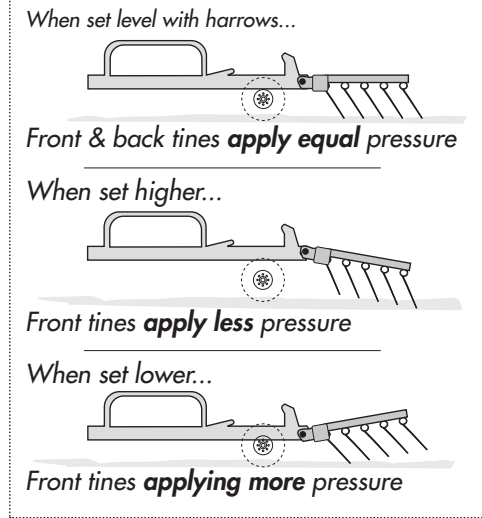

TRAILER/CART HEIGHT INDICATOR

Adjusted with "Wheel Height Cylinders".



- 5 } Adjust According to Tine Angle Setting
- 4 }
- 3 }
- 2 }
- 1 }
- 0 - Transport

NOTE: "0" indicates fully raised & "5" is lowest height.

Operation - Disc Angle Settings

DISC ANGLE INDICATOR

The disc angle is indicated by the edge of the disc frame bar in relation to the numbers on the disc angle reference decal.

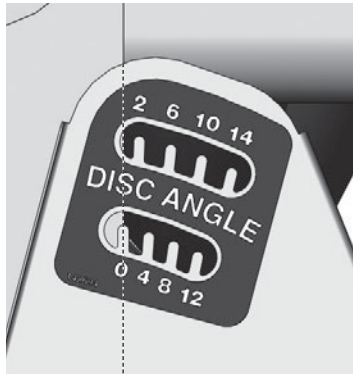

0°-4° with a coultter disc will allow you to open the ground and cut trash with minimal soil disruption.

5°-7° is good for mixing some dirt with residue while loosening the soil but still leave stubble standing to catch snow.

8°-10° is perfect for working low spots with high trash and for drying them out.

DISC ANGLE ADJUSTMENT

The angle for the discs is adjusted independently for each disc section. Follow the procedure below to adjust.

Setting Disc Angle

- Loosen Jam Nuts.
 - Adjust Turnbuckle.
 - Re-tighten Jam Nuts.
- (Each disc section is adjusted independently.)

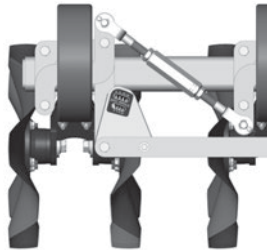

DISC DEPTH INDICATOR

The disc depth setting is adjusted according to the Tine Angle and Cart/Beam Height. For minimal tillage, place the disc depth circuit in float.

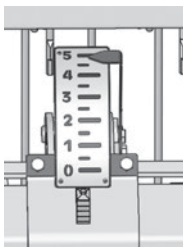

- 5 } Adjust
- 4 } According to
- 3 } Cart Height
- 2 } & Disc Depth
- 1 } Required.
- 0 — Transport

(For minimal tillage, use in float.)

DISC OPTIONS

Wave Samurai

- Good for cutting heavy trash and mixing soil while incorporating.
- Extremely aggressive edge maintains penetration and wear.
- Fluted disc allows blade to turn in heavy residue.
- **4° to 10°**, can be angled more aggressively if needed.

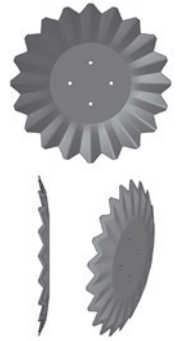

Wave Notched

- Good for maximum coverage and mixing soil at shallow working depth.
- 4" wave assist disc to turn in extreme conditions.
- Notches help disc penetrate and size material.
- Maintains constant cutting angle as it wears.
- **0° to 10°**.

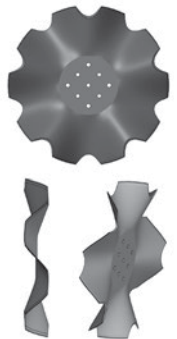

Curved Wave VT

- Good for opening ground and cutting with minimal soil disruption.
- Soil razor edge cuts aggressively with good wear characteristics.
- Curved waves allows blade to turn in heavy residue without turning soil over.
- **0° to 4°**, should not be angled aggressively.



Flattened Double V

- Good for cutting/sizing trash and incorporating.
- Aggressive edge maintains penetration and wear.
- Double V provides a smoother furrow.
- **2° to 10°**, can be used more aggressively if needed.



Operation - Adjustments: Rephasing Cylinders

Overview & Principles of Rephasing

A **Rephasing Cylinder System** enables a pair (or multiple) cylinders to extend and retract in very near unison.

Rephasing is accomplished by using a rephasing passageway which is located at the position of full extension. Many design techniques accomplish this but in simplicity, the **rephasing passageway** allows a small amount of hydraulic fluid to bypass the cylinder piston in the fully extended position ultimately allowing the cylinders to rephase.

This feature allows the cylinders to be aligned during set up and **rephased** in the event of oil leakage/by-pass during usage or after service work.

A rephasing cylinder system will consist of a master cylinder and 1 or more slave cylinders. These cylinders operate evenly to raise and lower the implement to the desired working depth.

Bleeding Air & Rephasing Function

Rephasing cylinder lift systems should be **rephased** periodically to purge any air that may be ingested into the system over time and/or compensate for drift due to system leakage.

To rephase the system, with the cylinder fully extended, actuate the cylinder valve for 30 seconds, or 5-10 seconds if you rephase often.

In a new rephasing circuit, a much longer time of maintaining a fully extended sequence may be required to bleed excessive air out of the circuit and may have to be repeated several times.

⚠ IMPORTANT: A rephasing cylinder circuit utilizes positive-displacement that effectively transfers power between cylinders, with the possibility of increasing internal pressures from cylinder to cylinder. Intensification occurs in hydraulic cylinders when there is pressure supplied to the full bore end of the hydraulic cylinder (extension) but the rod end (retraction) port becomes blocked or under excessive load. Pressure intensification may cause pressures to exceed the working pressure ratings of the cylinders themselves, or other components within the system. Safety awareness and caution should be taken to identify signs or causes of potential pressure build-up in the circuit.

Troubleshooting

Series rephasing cylinder systems (*Master and Slave(s)*) can exhibit undesirable behaviors such as **creep** (drift or movement when the hydraulic cylinder is not in use) or **failing to stay synchronized** (not extending and retracting at the same rate).

Below is a brief overview of some of the possible conditions that contribute to cylinder creep, drift or the series cylinder getting out of sync. Keep in mind that the cylinders are only part of the hydraulic circuit and there can be other contributing causes.

Cylinder rod measurement method:

Cylinder by-pass is a common field issue in series cylinder systems, and a systematic review is required to determine the problem.

- Extend the cylinders fully to the re-phasing position, then retract approximately 2+ inches away from the rephasing position.
- Immediately disconnect the hydraulics from tractor.
- Measure the length of the extended cylinder rod on each cylinder.
- Leave implement to stand for some an extended period of time, i.e. 3 hours.
- Re-measure length of rods again and compare before and after measurements.

Please note: Variation can be expected if the implement is left over a time where the temperature change affects the hydraulics by contraction or expansion. Warm to cooler temperatures will cause the series cylinders to move. Make sure measurements are taken at similar temperatures.

- When the 'suspect' cylinder has been identified, disassembly must be carried out in a clean environment. The scoring of barrels and piston seals will usually indicate contamination of some type has entered the system.

Air in the system:

If one or all of the cylinders drift or the system is 'spongy' air is likely entrained in the system. Check for air bubbles going back to the tank or by removing the return line and catching oil in a clean container. With the rod clevises disconnected and the cylinders horizontal (ports at 12 o'clock) or vertical, hold in the re-phasing position until no aerated oil flows.

Please note: Check the reservoir levels when carrying out this exercise. Once the air has been pushed out of the system the reservoir can become low. This can introduce air into the system again.

Service & Maintenance

⚠ MAINTENANCE SAFETY

- Review the Operator's Manual and all safety items before working with, maintaining or operating the Strawmaster X.
- Lower to ground, stop engine, place all controls in neutral, set park brake and remove ignition key before servicing, adjusting, repairing, or unplugging.
- Ensure wing jacks are down when parked.
- Keep hands, feet, clothing and hair away from all moving and/or rotating parts.
- Clear the area of bystanders, especially children, when carrying out any maintenance and repairs or making any adjustments.
- Place safety stands or large blocks under the frame before removing the tires or working beneath the machine.
- Be careful when working around or maintaining a high pressure hydraulic system. Wear the proper hand and eye protection when searching for a pin hole leak in a hose or fitting.
- Always relieve pressure before disconnecting or working on hydraulic system.

MAINTENANCE CHECKLIST

After reviewing the Maintenance and Hydraulic Safety Information, use the Maintenance Checklist provided for regular service intervals and keep a record of all scheduled maintenance:

(Initial break-in review.)

A. Before using:

1. Read Safety Info. & Operator's Manual.
2. Complete "Pre-Operation Checklist"
3. Check all Bolt Tightness.

B. After operating for 2 hours:

1. Check all hardware. Tighten as required.
2. Check all hydraulic system connections. Tighten if any are leaking.

MAINTENANCE SCHEDULE

After operating for initial 2 hours:

1. Check all hardware. Tighten as required.
2. Check all hydraulic system connections. Tighten if any are leaking.

After operating for initial 8 hours:

1. Check all hardware. Tighten as required.
2. Check all hydraulic system connections. Tighten if any are leaking.
3. Re-torque all bolts on harrow sections and mounting brackets.

Daily - 8 Hours

- Hydraulic Fluid Leaks
- Damaged Hoses
- Check Tire Pressure

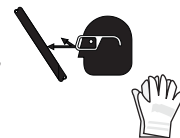

Tires: 560/60 x 22.5: **41 PSI** (283 kPa)

Tires: 500/60 x 22.5: **41 PSI** (283 kPa)

Weekly - 25 Hours

- Grease Endwheel Turrets (Top and Bottom - both sides)
- Grease Truss Arm Ball Joints
- Check Tire Wear
- Clean Safety Signs



Annually - 200 Hours

- Bolt Tightness
- Wheel Bearings
- Latch Mechanism



Service & Maintenance

HARDWARE SPECIFICATIONS

Note: Unless stated otherwise, hardware is typically:
Hex, Plated GR5 UNC or P8.8 (metric)

TORQUE SPECIFICATIONS

Checking Bolt Torque

The tables below give correct torque values for various bolts and capscrews. Tighten all bolts to the torques specified in chart unless otherwise noted. Check the tightness of bolts periodically, using these bolt torque charts as a guide. Replace hardware with the same strength (Grade/Class) bolt.

IMPERIAL TORQUE SPECIFICATIONS

(Coarse Thread - based on "Zinc Plated" values)



Size	Grade 5 lb.ft (N.m)	Grade 8 lb.ft (N.m)
1/4"	7 (10)	10 (14)
5/16"	15 (20)	20 (28)
3/8"	25 (35)	35 (50)
7/16"	40 (55)	60 (80)
1/2"	65 (90)	90 (120)
9/16"	90 (125)	130 (175)
5/8"	130 (175)	180 (245)
3/4"	230 (310)	320 (435)
7/8"	365 (495)	515 (700)
1"	550 (745)	770 (1050)
1-1/8"	675 (915)	1095 (1485)
1-1/4"	950 (1290)	1545 (2095)
1-3/8"	1250 (1695)	2025 (2745)
1-1/2"	1650 (2245)	2690 (3645)

METRIC TORQUE SPECIFICATIONS

(Coarse Thread - based on "Zinc Plated" values)



Size	Class 8.8 lb.ft (N.m)	Class 10.9 lb.ft (N.m)
M6	7 (10)	10 (14)
M8	16 (22)	23 (31)
M10	30 (42)	45 (60)
M12	55 (75)	80 (108)
M14	90 (120)	125 (170)
M16	135 (185)	195 (265)
M18	190 (255)	270 (365)
M20	265 (360)	380 (515)
M22	365 (495)	520 (705)
M24	460 (625)	660 (895)
M27	675 (915)	970 (1315)
M30	915 (1240)	1310 (1780)
M33	1250 (1695)	1785 (2420)
M36	1600 (2175)	2290 (3110)

HYDRAULIC SAFETY

- Make sure that all components in the hydraulic system are kept in good condition and are clean.
- Replace any worn, cut, abraded, flattened or crimped hoses and metal lines.
- Do not attempt any makeshift repairs to the hydraulic lines, fittings or hoses by using tape, clamps or cements. The hydraulic system operates under extremely high-pressure. Such repairs will fail suddenly and create a hazardous and unsafe condition.
- Wear proper hand and eye protection when searching for a high-pressure hydraulic leak. Use a piece of wood or cardboard as a backstop instead of hands to isolate and identify a leak. 
- If injured by a concentrated high-pressure stream of hydraulic fluid, seek medical attention immediately. Serious infection or toxic reaction can develop from hydraulic fluid piercing the skin surface.
- Before applying pressure to the system, make sure all components are tight and that lines, hoses and couplings are not damaged.

HYDRAULIC HOSE SPECIFICATIONS

Note: Unless otherwise stated, Hydraulic Hoses are either 3/8 or 1/2 with ORF female swivel ends.

HYDRAULIC HOSE INSTALLATION TIPS

The following tips are to help you identify some possible problem areas in the installation of hydraulic hoses.

1. Installation should be completed in a clean environment clear of dust and contaminants. Hoses and fittings should be capped if not installed.
2. Ensure hoses are not twisted during installation as this may weaken the hose. Also, the pressure in a twisted hose may loosen fittings or connections.
3. Allow sufficient bend radius in hoses when installing to prevent lines from collapsing and flow becoming restricted.
4. When installing hoses in an area of movement or flexing, allow enough free length for motion and to ensure fitting connections are not stressed.
5. Ensure hoses are properly clamped and secured in position after routing is complete to provide a cleaner installation and prevent possible damage or hazards.

Service & Maintenance

HYDRAULIC FITTING INSTALLATION



The following info is to help you identify and properly install some of our standard hydraulic fittings.

SAE (JIC) 37° Flare

JIC fittings - Metal-to-metal sealing type fittings featuring a 37° flare (angle of sealing surface) and straight UNF (Unified National Fine) Threads.

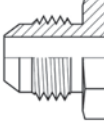
(Lubricated Values)	Dash	Thread Size	Torque - lb.ft (N.m)
	-4	7/16 - 20	9-12 (12-16)
	-6	9/16 - 18	14-20 (19-27)
	-8	3/4 - 16	27-39 (37-53)
	-10	7/8 - 14	36-63 (50-85)
	-12	1-1/16 - 12	65-88 (90-119)

Tightening JIC 37° Flare Type Fittings

1. Check flare and flare seat for defects that might cause leakage.
2. Align fittings before tightening. Lubricate connections & hand tighten swivel nut until snug.
3. Using two wrenches, torque to values shown in table.

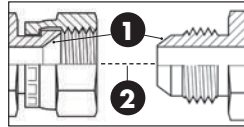

Alternate Installation Method

3. Using two wrenches. Place one wrench on the fixed connector body at a clock position of 6 o'clock.
4. Place the second wrench on the second connection as close to the 3 o'clock position as possible.
5. Tighten by rotating the second connection firmly to at least the 4 o'clock position, but no more than the 7 o'clock position. Typically, the larger the fitting size the less rotation required.

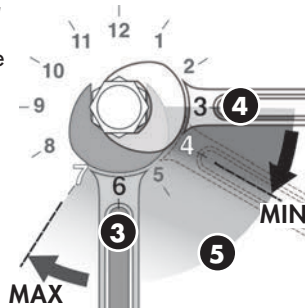

ORFS (O-Ring Face Seal)

ORFS fittings use an O-ring compression method to seal. This method offers a high level of sealing along with good vibration resistance. Male fittings include an O-ring located in a groove on the flat face. Female fittings feature a flat face and UNF straight threaded swivel nut.

The **Torque** method is recommended for ORFS installation.

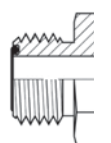
	Dash	Thread Size	Torque - lb.ft (N.m)
	-4	9/16 - 18	18 (25)
	-6	11/16 - 16	30 (40)
	-8	13/16 - 16	40 (55)
	-10	1 - 14	60 (80)
	-12	1-3/16 - 12	85 (115)

Tightening ORFS (O-Ring Face Seal) Fittings

1. Inspect components and ensure the O-Ring seal is undamaged and properly installed in the groove of the face seal. Replacing the O-Ring may be necessary.
2. Align, thread into place and hand tighten.
3. Tighten to proper torque from the table shown above.

Note: A **DASH** size refers to a diameter of a hose (*inside*) or of a tube (*outside*) measured in 1/16" increments. For example, a **Hose** specified as **dash 8** or **-8** would have an **inside** diameter of **8/16"** or **1/2"**. Alternatively, a **Tube** specified as **dash 8** or **-8** would have an **outside** diameter of **8/16"** or **1/2"**.

ORB (O-Ring Boss)

Male ORB fittings have straight UNF threads, a sealing face and an O-ring. The female fittings are generally found in the ports of machines and feature straight threads, a machined surface, and a chamfer to accept the O-ring. Sealing is achieved through the compression of the male O-ring against the chamfered sealing face of the female fitting.

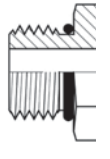
(Lubricated Values)	Dash	Thread Size	Torque	
			Non-Adjustable lb.ft (N.m)	Adjustable lb.ft (N.m)
	-4	7/16 - 20	30 (40)	15 (20)
	-6	9/16 - 18	35 (46)	35 (46)
	-8	3/4 - 16	60 (80)	60 (80)
	-10	7/8 - 14	100 (135)	100 (135)
	-12	1-1/16 - 12	135 (185)	135 (185)

Tightening ORB (O-Ring Boss) Fittings

Non-adjustable Port End Assembly

1. Inspect the components to ensure that male and female threads and sealing surfaces are free of nicks, burrs, scratches, or any foreign material.
2. Ensure O-Ring seal is properly installed and undamaged.
3. Lubricate threads and O-ring to help the O-ring slide past the port entrance corner and avoid damaging it.
4. Screw the fitting into position tighten to proper torque value from the table shown above.

Adjustable Port End Assembly

1. Inspect the components to ensure male & female threads and sealing surfaces are free of nicks, burrs, scratches, or any foreign material.
2. Ensure O-Ring seal is properly installed and undamaged.
3. Lubricate threads and O-ring to help the O-ring slide smoothly into the port and avoid damage.
4. Loosen back the lock nut as far as possible. Make sure back-up washer is not loose and is pushed up as far as possible.
5. Screw the fitting into port until the back-up washer or the retaining ring contacts face of the port. Light wrenching may be necessary. Over tightening may damage washer.
6. To align the end of the fitting to accept incoming tube or hose assembly, unscrew the fitting by the required amount, but not more than one full turn.
7. Using two wrenches, hold the fitting in desired position and tighten the locknut to the proper torque value from the table located above.
8. Inspect to ensure that O-ring is not pinched and that washer is seated flat on the face of the port.

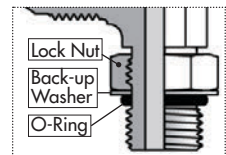

Service & Maintenance

HYDRAULIC CYLINDER REPAIR

PREPARATION

When cylinder repair is required, clean off unit, disconnect hoses and plug ports before removing cylinder.

When removed, open the cylinder ports and drain the cylinder's hydraulic fluid.

Examine the type of cylinder. Make sure you have the correct tools for the job.

You may require the following tools:

- Proper **Seal Kit**
- Allen Key Set
- Emery cloth
- Torque Wrench

Threaded Head Cylinder (Monarch)

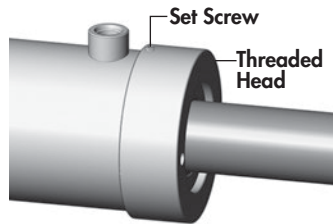

CYLINDER ROD LOCKNUT TORQUE VALUES

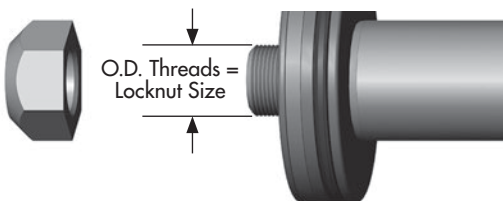

LOCKNUT SIZE (PISTON)	TORQUE VALUE
3/8 - 24 UNF	25-30 lb.ft (35-42 N.m)
1/2 - 20 UNF	40-60 lb.ft (55-80 N.m)
5/8 - 18 UNF	95-105 lb.ft (130-140 N.m)
3/4 - 16 UNF	175-225 lb.ft (240-305 N.m)
7/8 - 14 UNF	200-275 lb.ft (270-370 N.m)
1 - 14 UNF	300-380 lb.ft (405-515 N.m)
1 1/8 - 12 UNF	400-500 lb.ft (540-675 N.m)
1 1/4 - 12 UNF	500-600 lb.ft (675-810 N.m)
1 1/2 - 12 UNF	700-800 lb.ft (950-1085 N.m)
1 3/4 - 12 UNF	800-900 lb.ft (1085-1220 N.m)

REPAIRING A THREADED HEAD CYLINDER

Set Screw Style

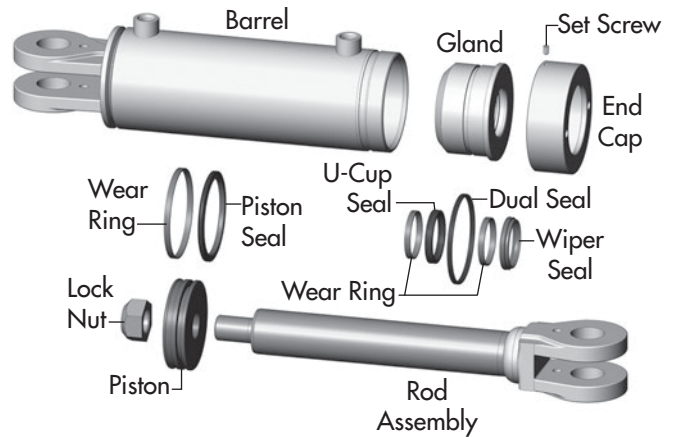

DISASSEMBLY

1. Loosen Set Screw and turn off end cap.
2. Carefully remove piston/rod/gland assemblies.
3. Disassemble the piston from the rod assembly by removing lock nut.

NOTE: DO NOT clamp rod by chrome surface.

4. Slide off gland assembly & end cap.
5. Remove seals and inspect all parts for damage.
6. Install new seals and replace damaged parts with new components.
7. Inspect the inside of the cylinder barrel, piston, rod and other polished parts for burrs and scratches. Smooth areas as needed with an emery cloth.

REASSEMBLY

1. Reinstall rod through end cap & gland assembly.
2. Secure piston to rod with lock nut. Torque lock nut to proper value (refer to chart for proper torque value).
3. Lube inside of barrel, piston seals, and gland seals with hydraulic oil.
4. With cylinder body held gently in a vise, insert piston, gland, end cap and rod combination using a slight rocking motion.
5. Apply Loctite anti-seize before installing cylinder end cap.
6. Torque cylinder end cap to 440 lb.ft (600 N.m).
7. Tighten Set Screw on end cap to 6 lb.ft (8 N.m).

Service & Maintenance

REPLACING A PRESSED BUSHING

NOTE: You may need the following tools:
Press, hammer, punch, pry-bar, "Step-Tool"

Use the following as a guideline for repair:

1. Ensure the area and frame are properly secured, supported, and safe to work on. Safely remove the pin(s), cylinder, and/or components necessary in order to access and work on the damaged bushing.
2. Remove the existing bushing using required tools. In some instances, you may need to cut the damaged bushing in order for easier removal (use proper safety precautions and try not to damage other components if using this method).
3. With the bushing removed, clean and prepare the location for the new bushing insert.

Note: It is recommended to use a mixture of "Dish Soap and Water" as a lubricant on the outside of the composite bushing. **IMPORTANT: DO NOT** use oil or grease on outside or inside of composite bushings.

4. Use a stepped tool to ensure the edge of the bushing is not damaged when inserting.

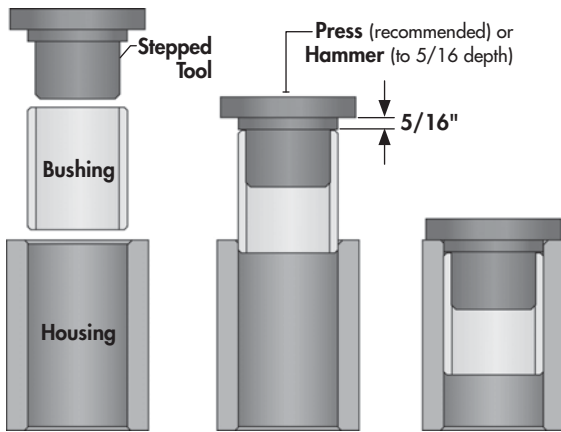

5. Ensuring the bushing is properly aligned, press into hole (preferred method) or hammer into position by striking the stepped tool.
6. Continue to install until the bushing edge is recessed in to a distance of 5/16" to allow for the outer seal to be properly installed. Do not exceed this depth.
7. Repeat procedure for bushing on opposite side.

8. When both bushings are installed to the proper depth, install new seals.

9. Re-assemble all other necessary components.

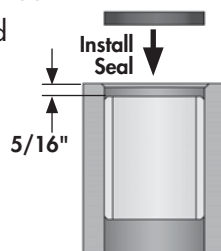

Service & Maintenance

WHEEL HUB REPAIR

DISASSEMBLY

1. Remove dust cap.
2. Remove cotter pin from nut.
3. Remove nut and washer.
4. Pull hub off spindle.
5. Dislodge the inner cone bearing and dust seal.
6. Inspect cups that are press fitted into hub for pits or corrosion and remove if necessary.
7. Inspect and replace defective parts with new ones.

IMPORTANT: Be sure to block up unit securely before removing tires.

COMMON HUB & SPINDLE COMPONENTS

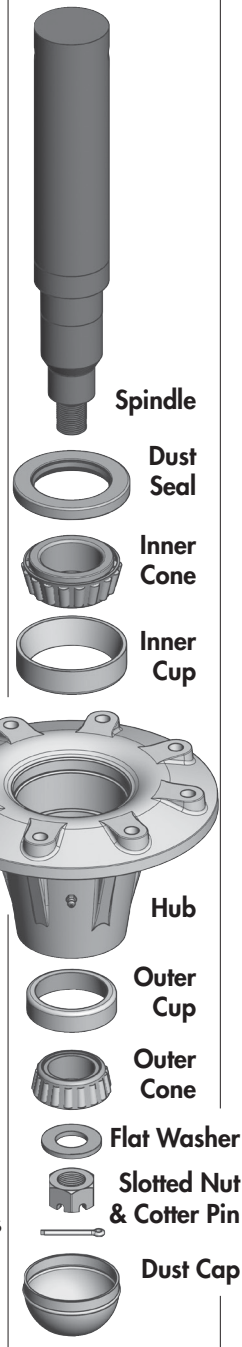

ASSEMBLY

1. If cups need replacing, be careful to install them gently and evenly into hub until they are fully seated.
2. Apply a thick wall of grease inside hub. Pack grease in cones.
3. Install inner cone and dust seal as illustrated.
4. Position hub onto spindle and fill surrounding cavity with grease.
5. Assemble outer cone, washer and nut.
6. Tighten nut while rotating hub until there is a slight drag.
7. Turn nut back approximately 1/2 turn to align cotter pin hole with notches on nut.
8. Install cotter pin and bend legs sideways over nut.
9. Fill dust cap half full of grease and gently tap into position.
10. Pump grease into hub through grease fitting until lubricant can be seen from dust seal.

WHEEL NUT & WHEEL BOLT TORQUE



BOLT PATTERNS

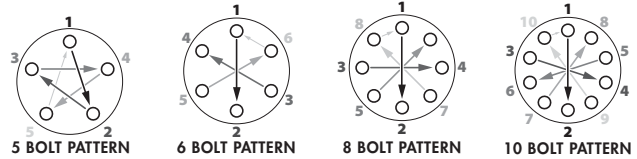

Wheel Nut/Bolt Torque

Size	lb.ft (N.m)
9/16	120-130 (165-175)
5/8	185-190 (250-260)
3/4	280-300 (380-405)

Wheel Tightening Procedure

1. Install and **hand tighten** nuts/bolts.
2. Tighten to approx. **20% Torque** value using the Bolt **Star or CrissCross** patterns shown above.
3. Tighten to **Full Torque** value using the **Star or CrissCross** pattern.
4. If applicable, install **Rear Locknuts** using **Wheel Torque Values**.

WHEEL NUT / BOLT TORQUE

1. The Recommended 5/8 wheel nut/bolt torque for this implement is 185-190 lb.ft (250-260 N.m)
2. When attaching the wheel, tighten to this specifications. Check again after approximately 500 revolutions and re-tighten as required.
3. Check wheel bolts twice annually to ensure proper bolt torque.

Service & Maintenance - Tine Replacement

TINE REPLACEMENT

Note: Tines **must** be replaced when worn down to 20 in. or less in length. Tines may be replaced while the machine is in transport position, or field position.

NOTE: Avoid replacing one tine at a time, unless wear is minimal. Tines should be replaced all at once whenever possible so there is even wear to all the tines. In some instances, (raking operations) the front row of tines will wear sooner. If this is the case, replace the front row. Check that wear is minimal on the other tines.

(Note: Harrow designs may vary from shown, but the overall procedure is the same.)

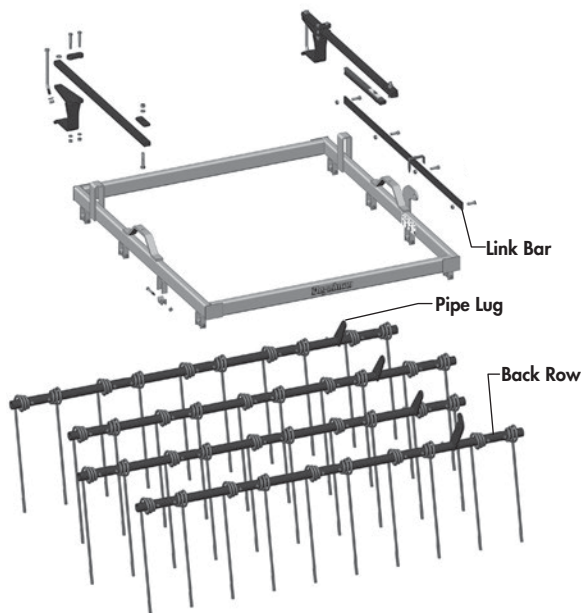

DISASSEMBLY:

Follow this procedure one pipe row at a time so pipes do not get mixed up, or number each pipe before disassembly.

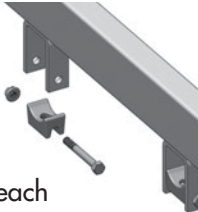
1. Remove the bolt from the link bar to pipe lug, so pipe will rotate freely. 
2. Remove the pin from the back end of the jack if the back row is being replaced. (Not Shown)
3. Remove the bolts and spacer from the bracket on the sides of the frame. The row will drop out. 
4. Remove the bolts holding the tines on the pipe. (Starting at each end and working in)
5. Slide the tines off the pipe.

ASSEMBLY:

1. Slide the tines onto the pipe. (Make sure all tines are installed facing the same direction) 
2. Position tines centred over bolt holes as shown in the diagram. Install bolts and nuts.
3. Position pipe between the brackets on the sides of the frame, with the lug on the outside of the frame. Install the spacer and bolt, secure with locknut. Ensure pipe turns freely when tightening.

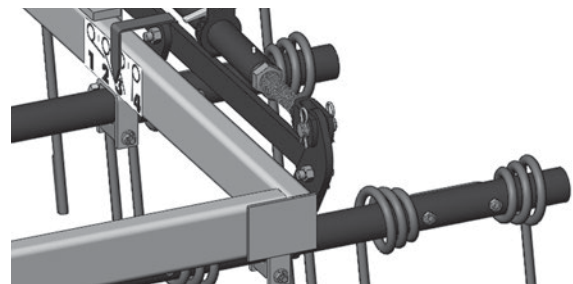

4. Line up hole on lug with hole on link bar, install bolt and secure with nut.
5. Back row: Install pin through the cylinder and lug. Secure with hair clip.
6. See the adjustments section and adjust as required.

Troubleshooting

GENERAL TROUBLESHOOTING

In the following section, we have listed some of the problems, causes, and solutions that you may encounter. If you encounter a problem that is difficult to solve, even after having read through this troubleshooting section, please call your local dealer or distributor. Before you call, have this manual and the serial number from your unit ready.

SYMPTOM	PROBLEM	SOLUTION
Hydraulics creep down during operation.	Damaged hose or loose fittings.	Search for leaks with a piece of paper (not by hand) and repair.
	Hydraulic cylinder leak.	Replace seals or damaged components.
	Tractor hydraulic leak.	To verify, raise sections half way up, disconnect at tractor. Observe if sections creeps down. If not repair tractor hydraulics.
Harrow sections raise too slowly.	Hydraulic pressure from tractor too low.	Check pressure, should be 2500 psi.
	Restriction in hose.	Disconnect & blow out lines with compressed air.
	External hydraulic leak.	Repair as needed.
Oil accumulation on cylinder shaft.	Hydraulic cylinder leak.	Replace seals or damaged components.
	Oil bypassing seals.	Seal manufacturer advises that small amounts of oil getting past seals is desirable. If problem becomes excessive, replace seals.
Auto-Fold latch will not close for field position.	Truss clamp has slid on wing frame.	With machine in field position and sections raised up, adjust the wing beam support arm distance (refer to maintenance section).
Auto-Fold latch will not open for transport position.	External hydraulic leak.	Search for leaks with a piece of paper (not by hand) and repair.
	Hydraulic cylinder leak.	Replace seals or damaged components.
One wing seems to fall back, not straight with the other wing.	The Wing Beam Truss Arm Clamps may have shifted or slid slightly on the wing beam.	With machine in field position and sections raised up, adjust the wing beam support arm distance (refer to maintenance section).
Dirt lumps in straw.	Do not hold straw in harrows while aggressively discing.	Reduce tine angle or pressure.
		Reduce disc angle to move less dirt.

Part Section Overview

PARTS SECTION - TABLE OF CONTENTS

Part Assemblies & Components

Front Trailer Overview/Components	22
Rock Shaft Components	25
Center & Wing Beam Components	26
End Wheel Components	27
Wing/Center Beam Mount Locations	28
Disc Section Assemblies & Components	30
Harrow Section Components	36
Wing Section Components	38

Hydraulic Routing

Hydraulic Routing - Wheels	37
Hydraulic Routing - Transport	40
Hydraulic Routing - DOC	41
Hydraulic Routing - Tine Angle	42
Hydraulic Routing - Latch & End Wheel	43
Hydraulic Routing - Jack	45
Electrical Layout & Light Components	46

Warranty

47

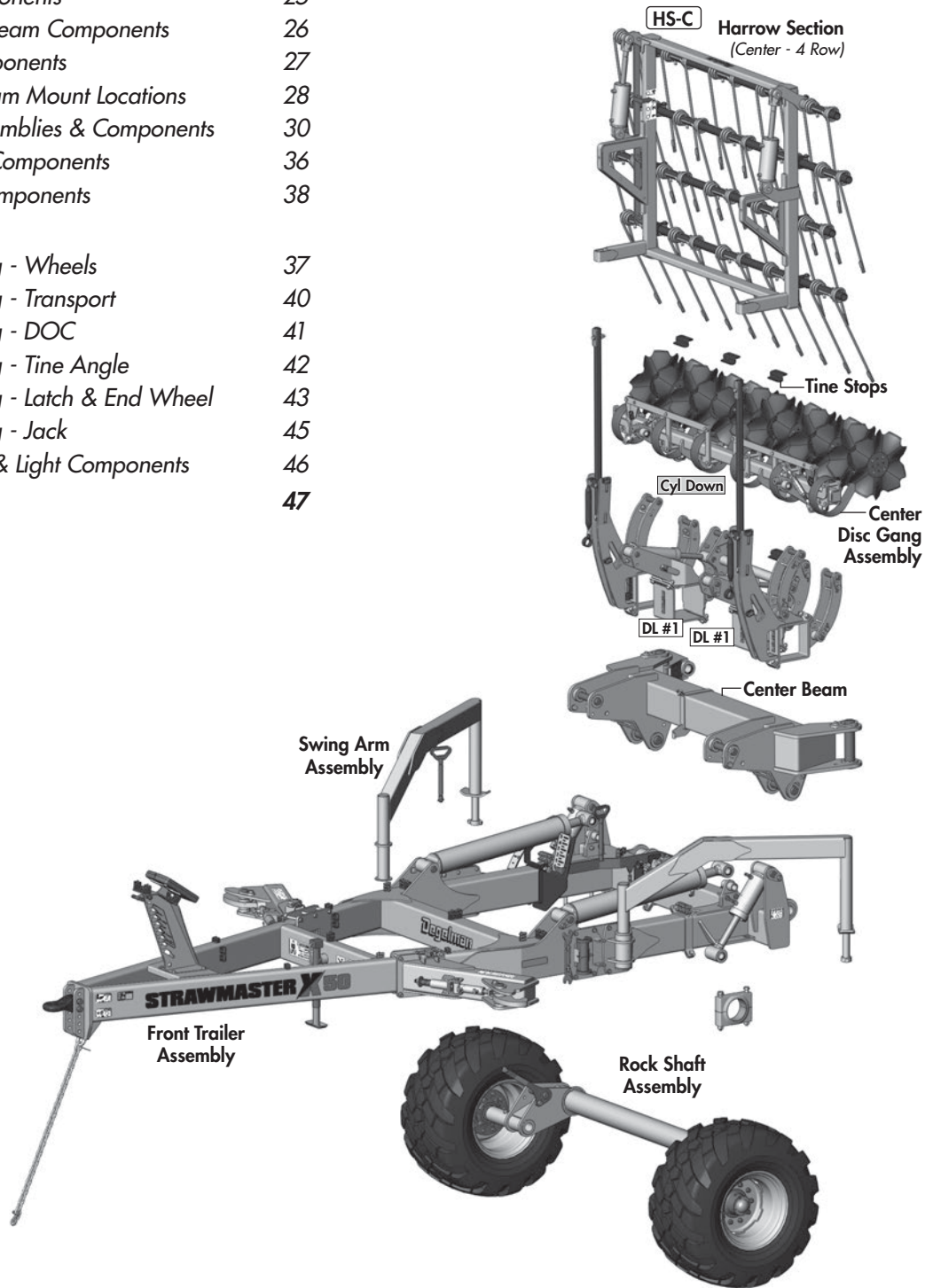

Part Section Overview

LH Wing Assembly Overview

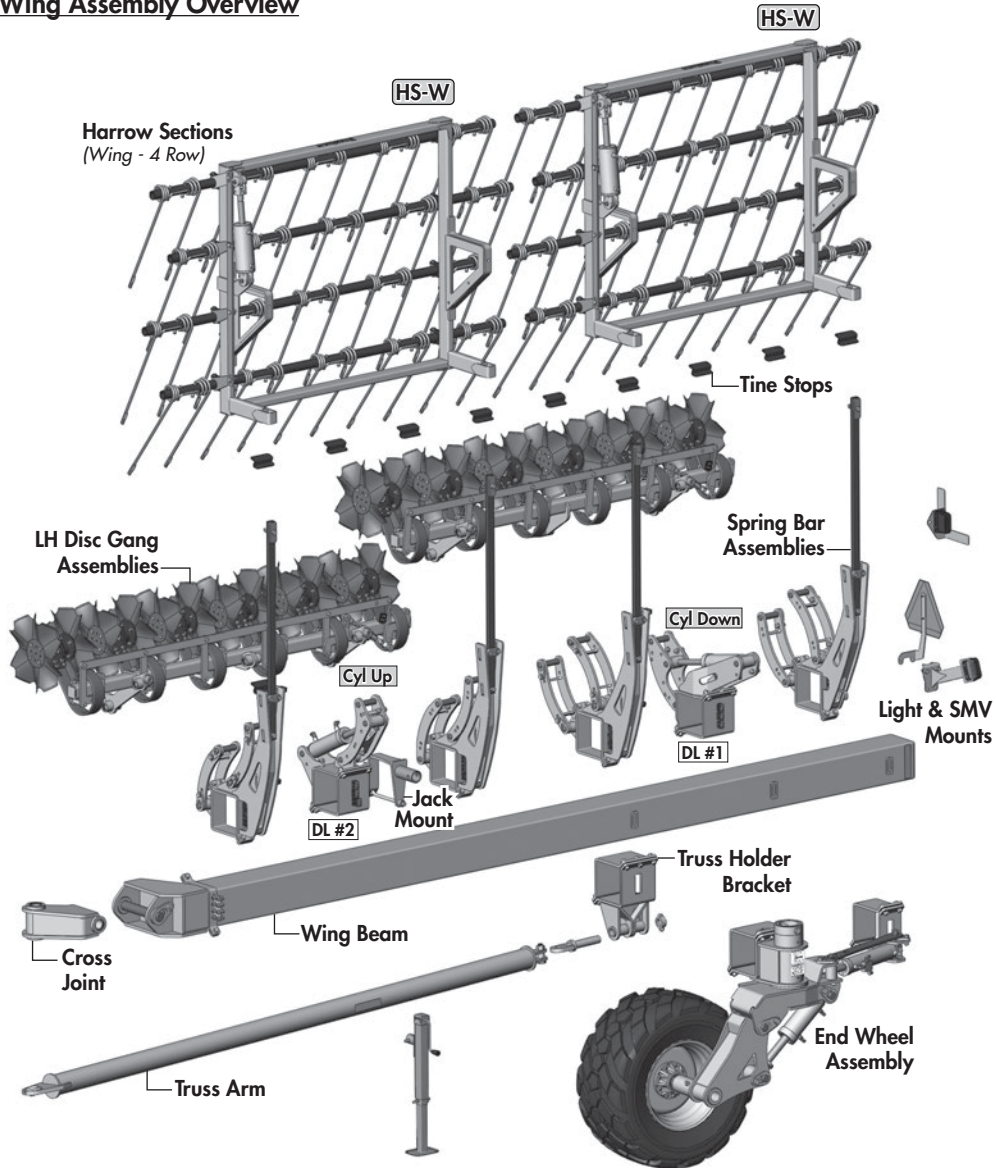

Transport Overview

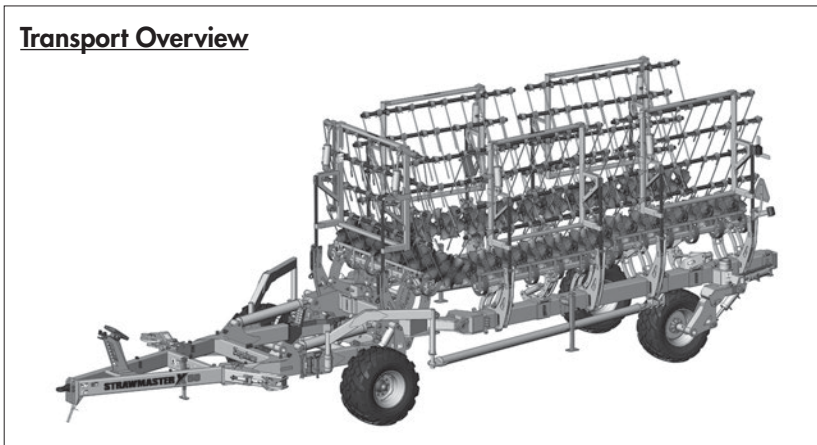

Front Trailer Components

Front Trailer Frame Components

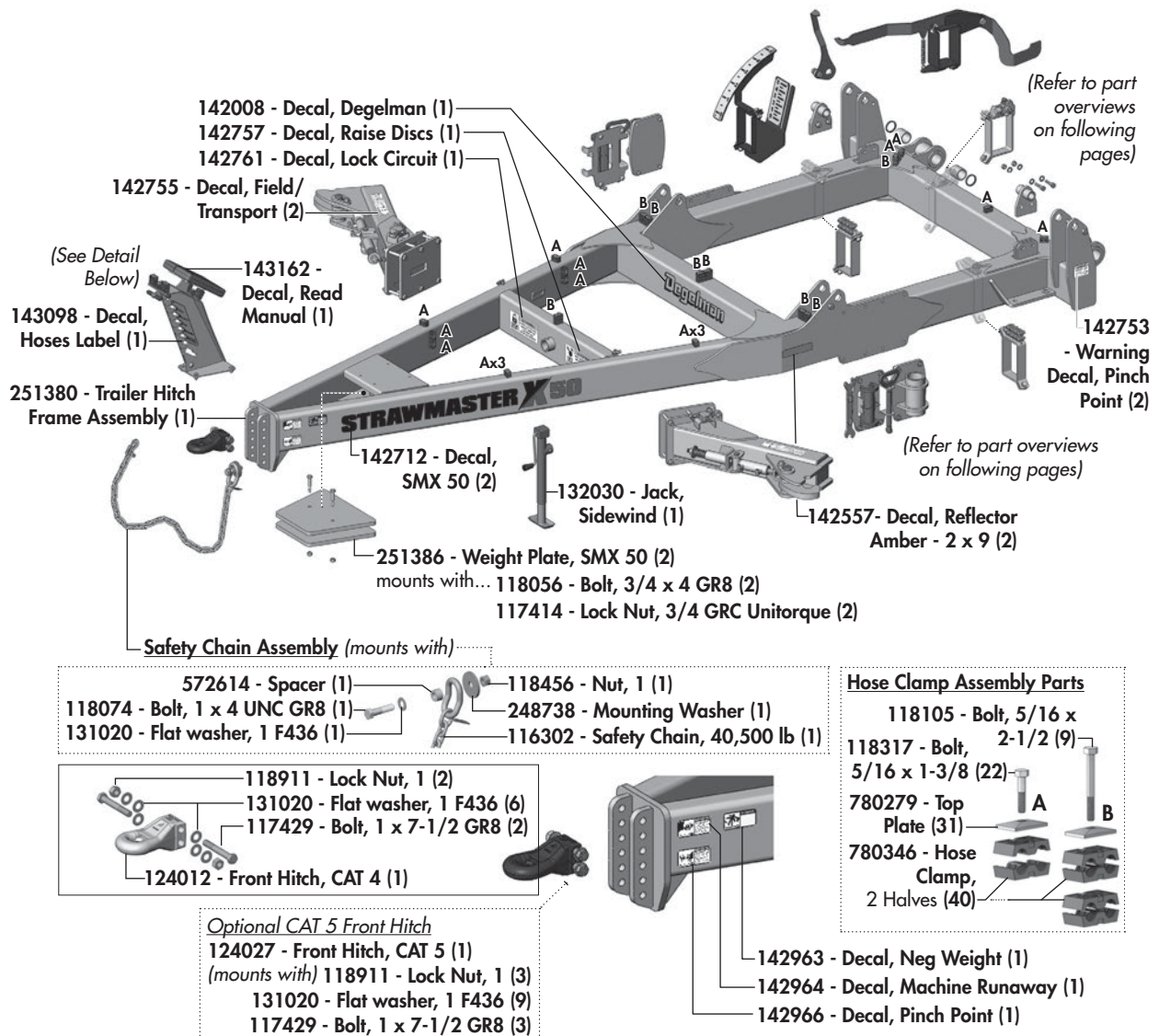

Hose Mount Components

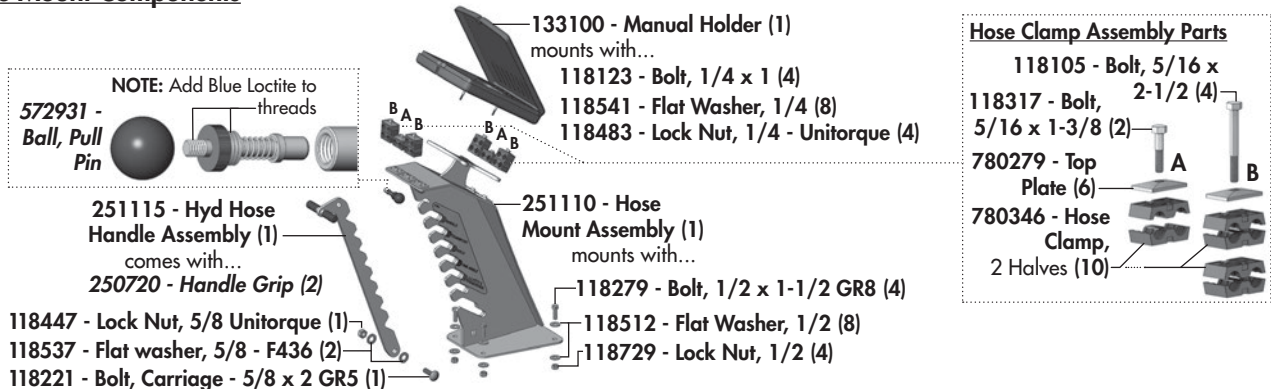

Front Trailer Components

Latch Arm Assembly Overview

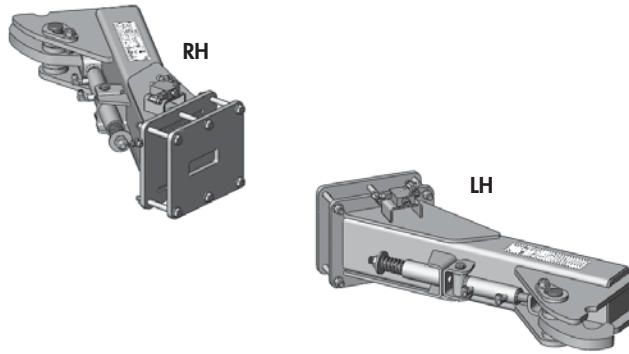

Exploded Latch Components

(LH exploded assembly shown)

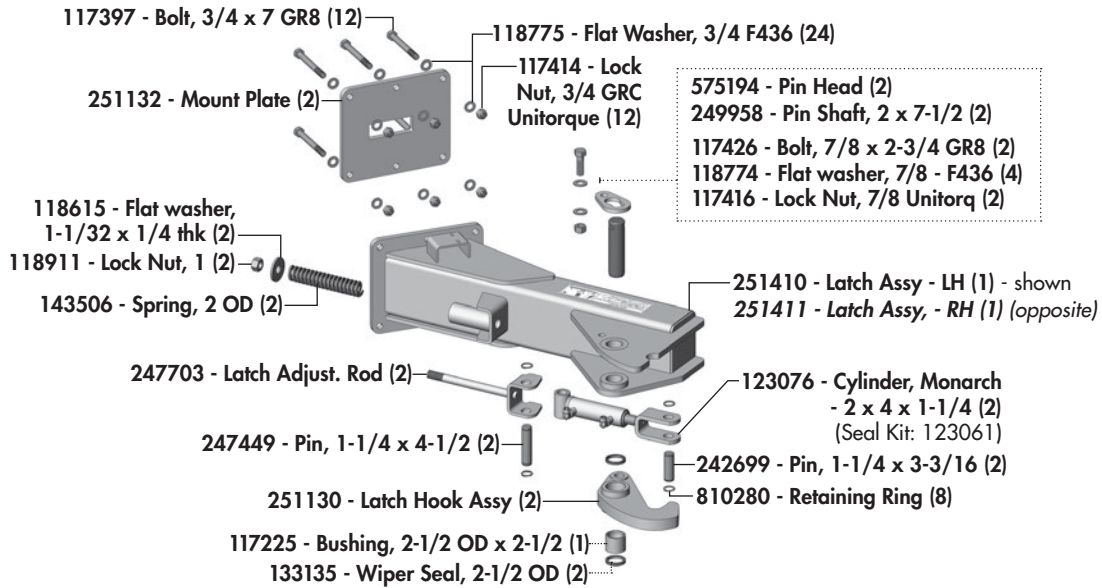

Swing Arm Components

(LH exploded assembly shown)

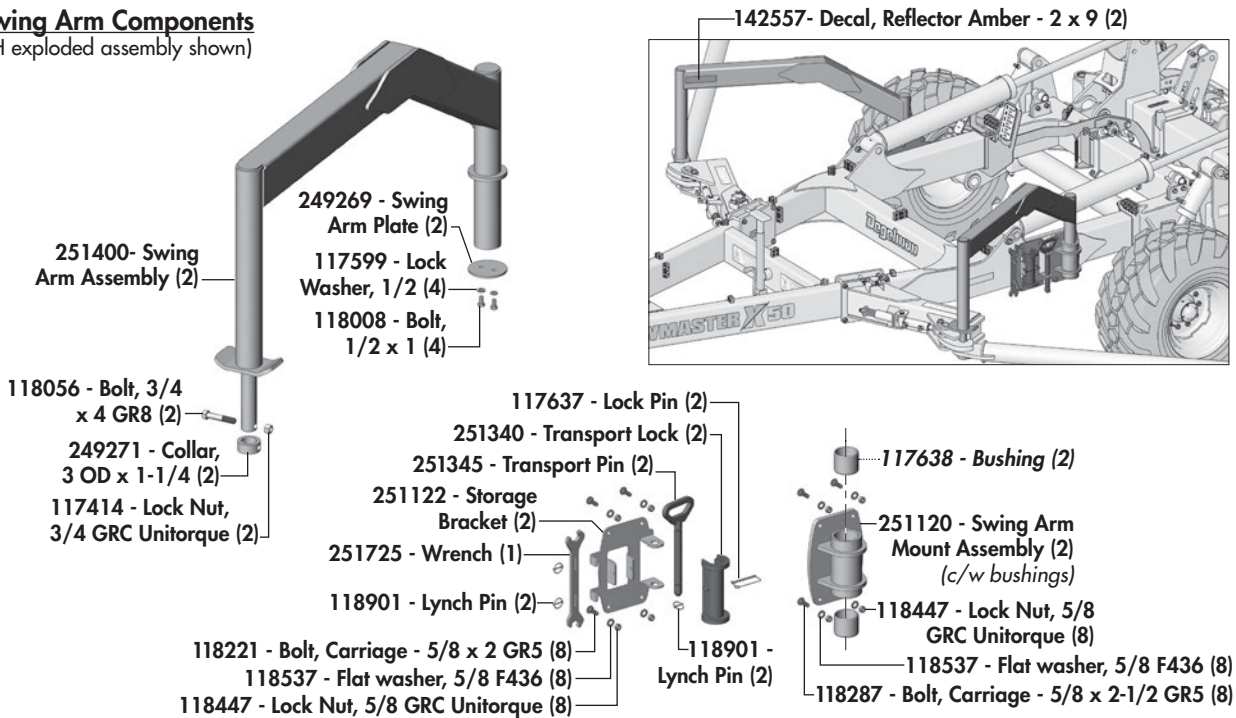

Front Trailer Components

Other Components

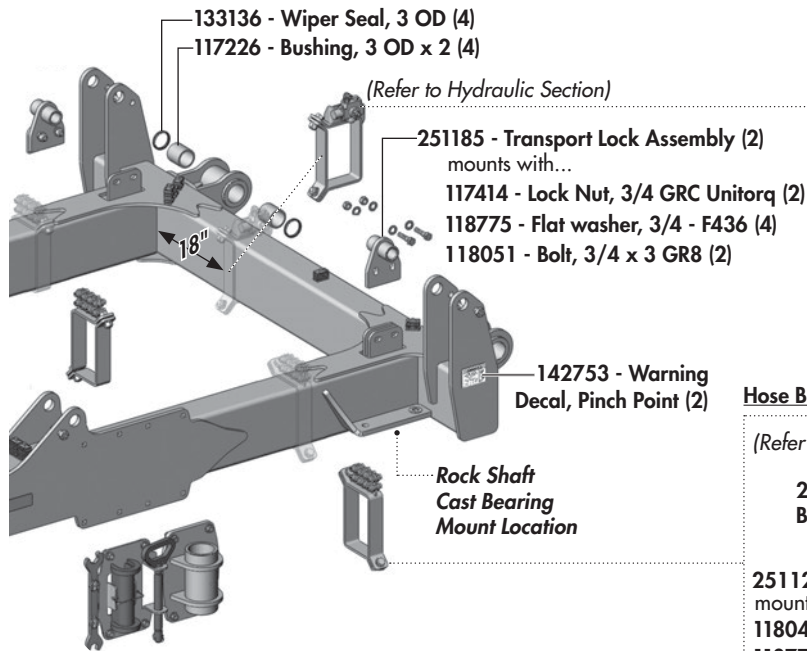

Valve Bracket Assembly

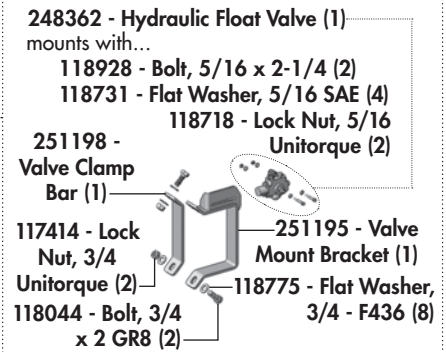

Hose Bulkhead Assembly (2)

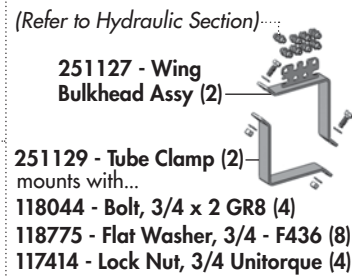

Indicator Assembly Components

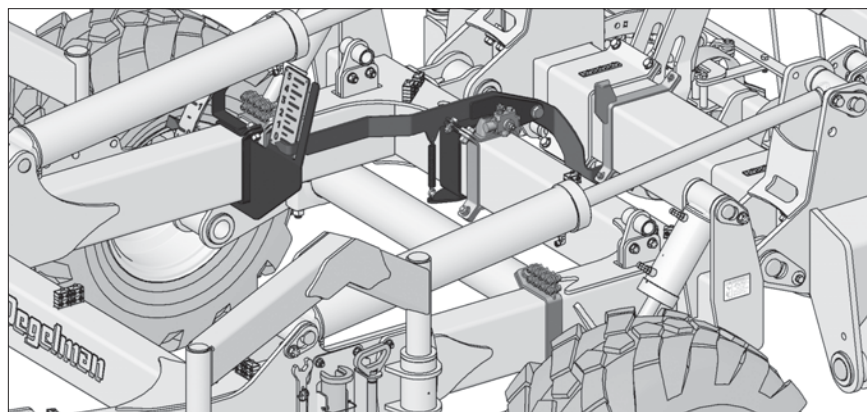
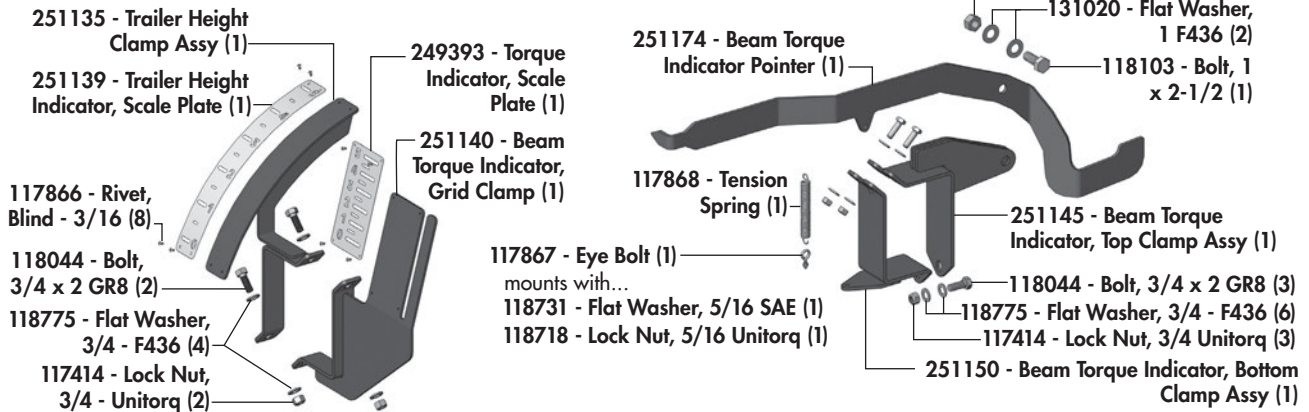

Rock Shaft Components

Rock Shaft Components

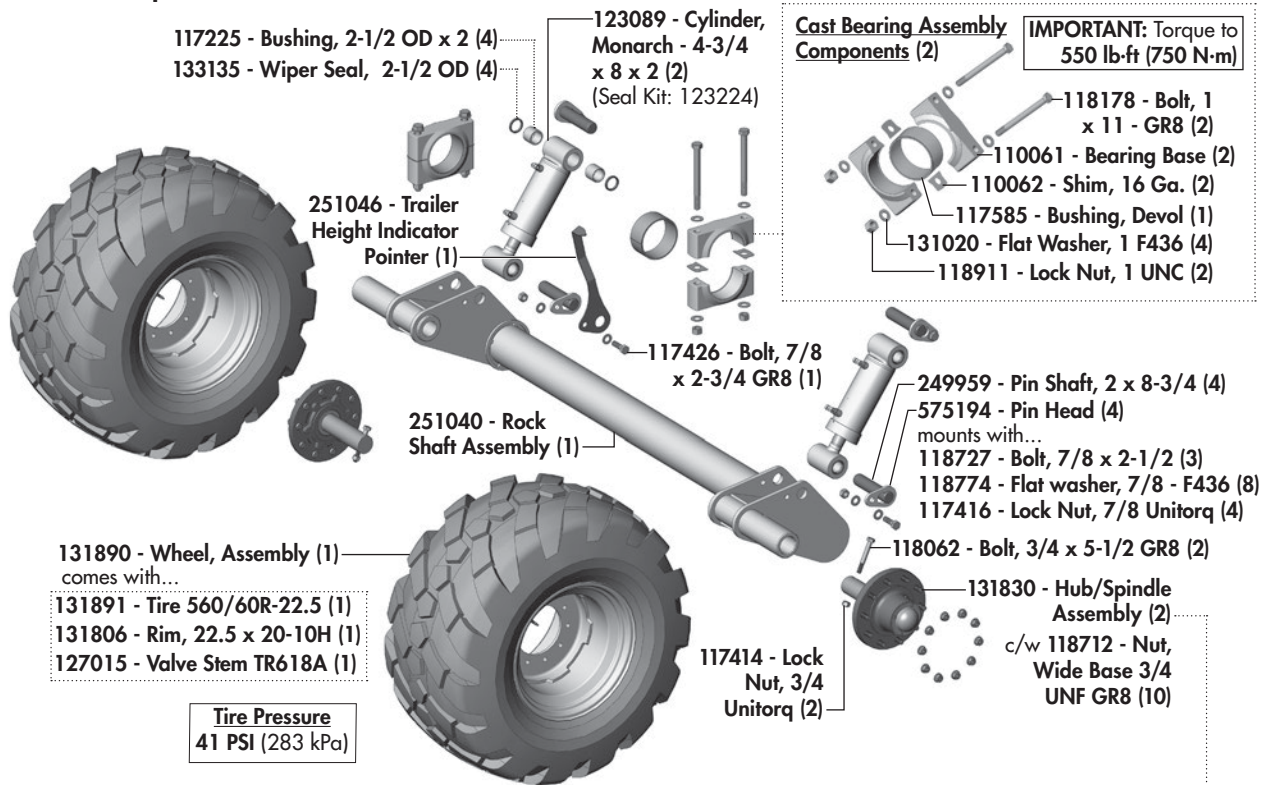

131830 - Hub/Spindle Assembly (2)

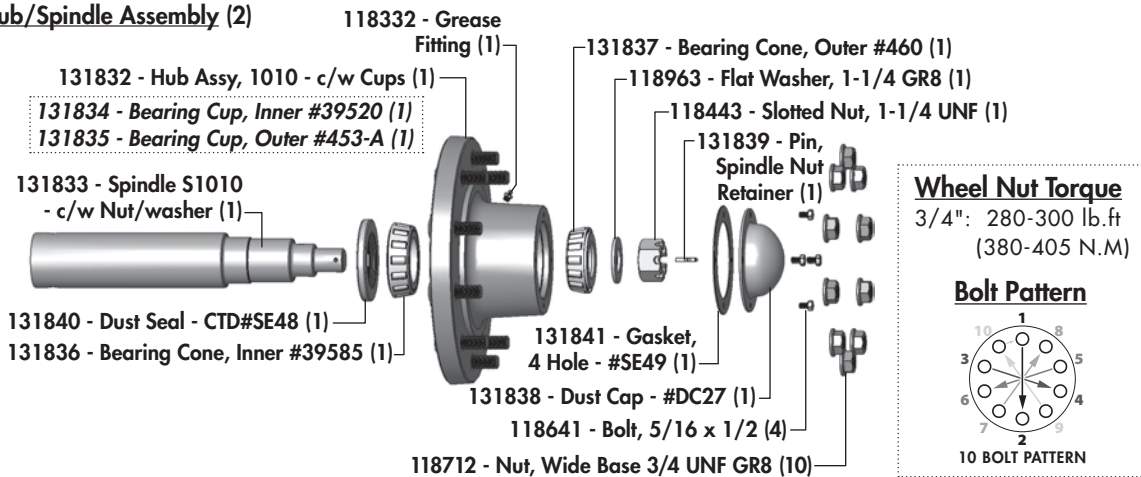

End Wheel Hub/Spindle Components

131616 - Hub / 3" Spindle Assembly (2)

Requires: 131776 - Wheel Nut, 5/8 - 18 UNF (8)
 Torque, 5/8 Wheel Nuts to: 185-190 lb.ft (250-260 N.m)

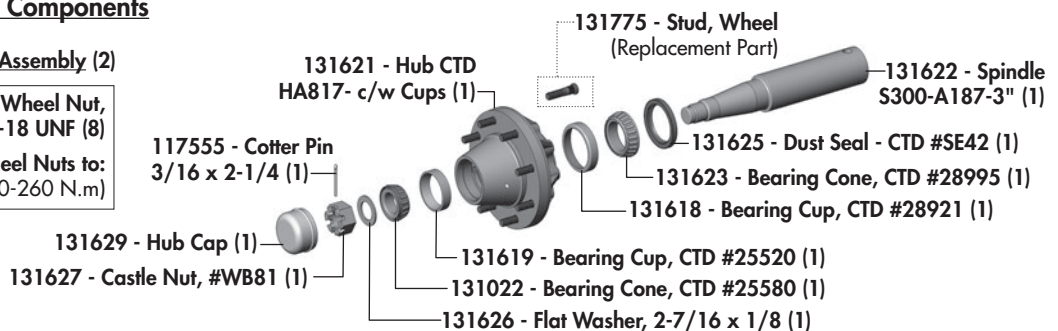

Center & Wing Beam Components

Center Beam Components

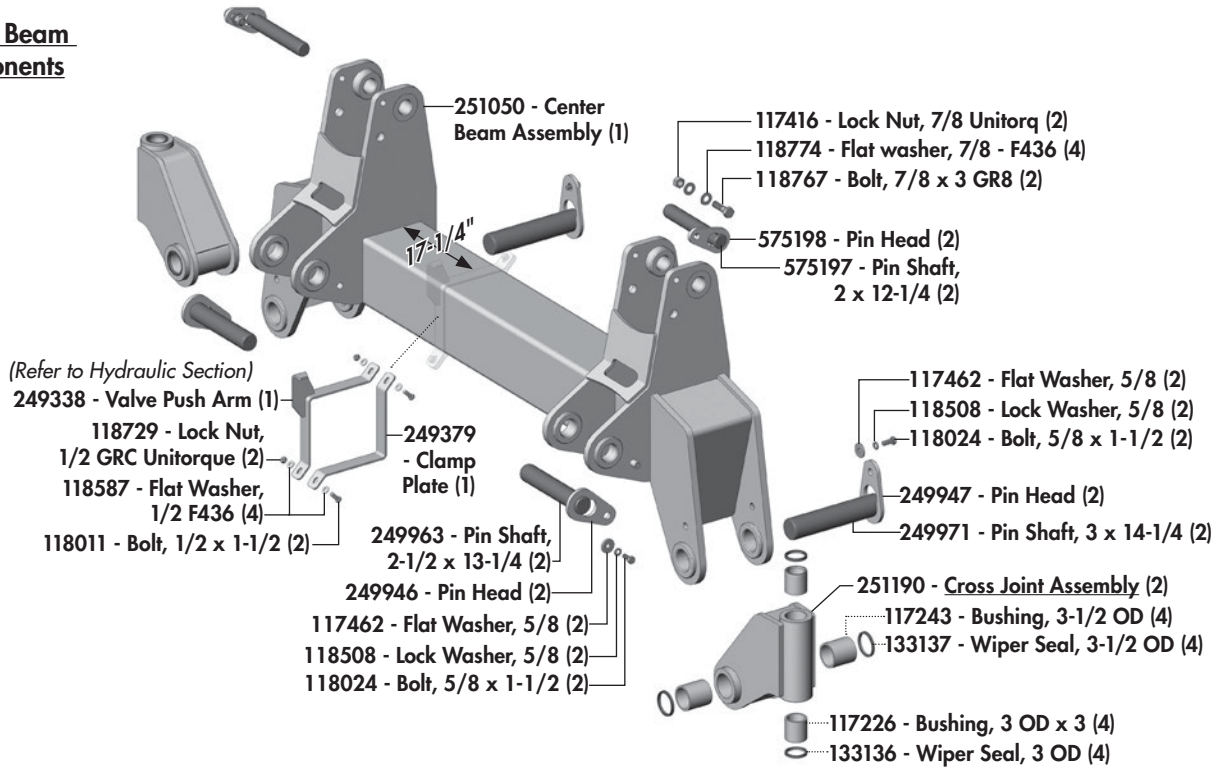

Wing Beam Components

(LH wing beam shown)

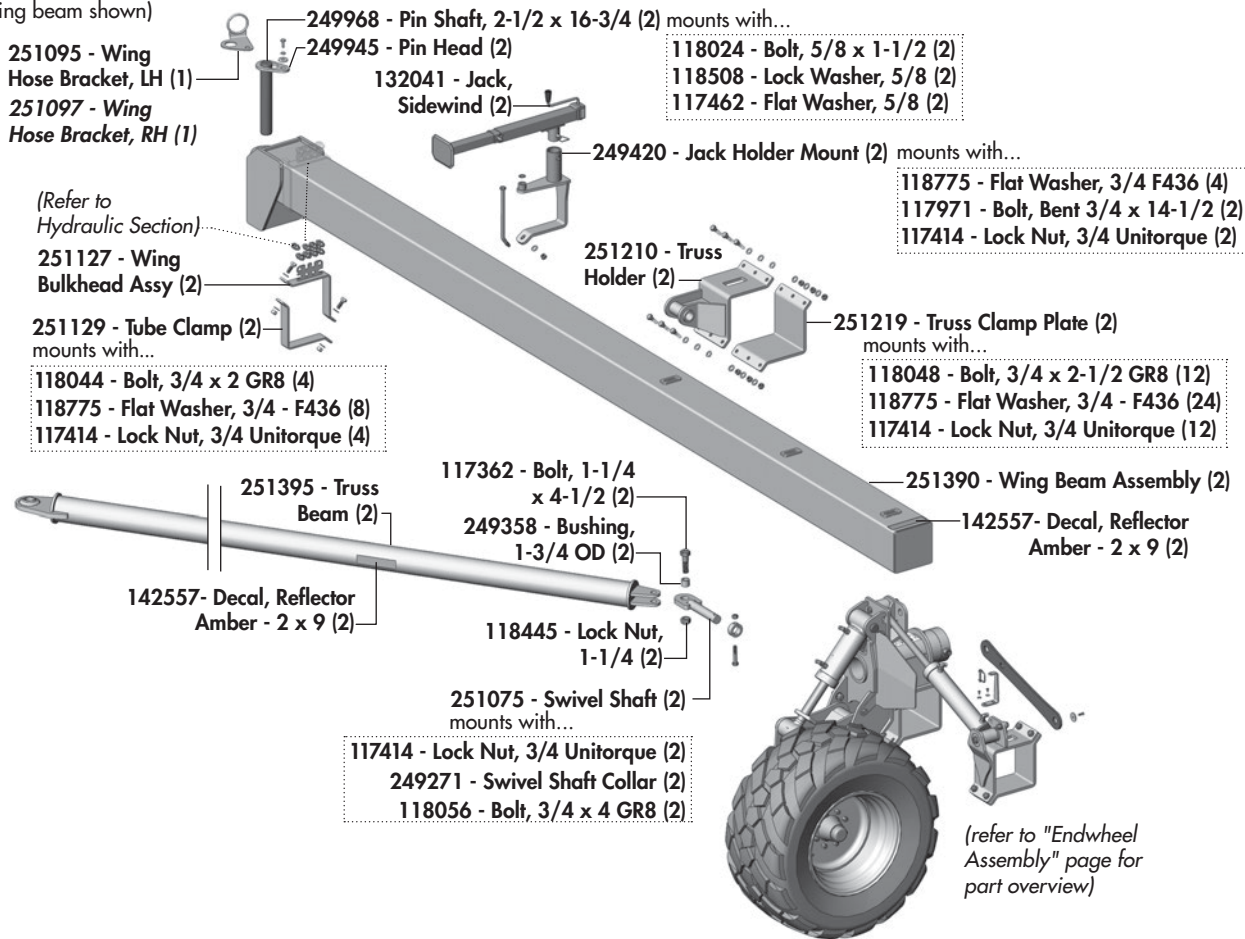

End Wheel Assembly

End Wheel Overview

(LH Shown - RH is Mirrored)

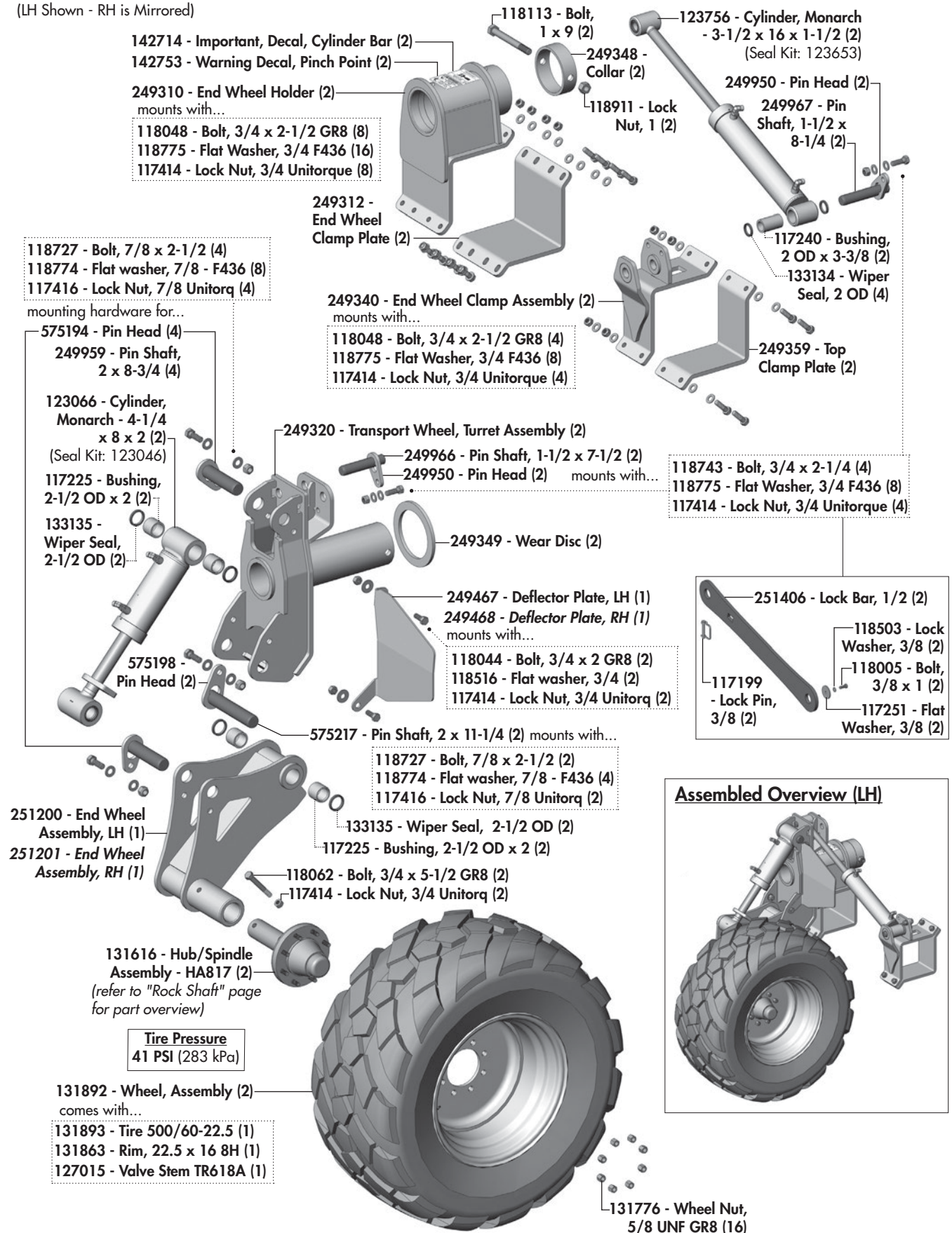

Wing/Center Beam Mount Locations

Strawmaster X Top Overview

(Location overview for Disc Assembly and Harrow Section mounting)

HS-C - Harrow Section - Center

HS-W - Harrow Section - Wing

DL # - Disk Arm Linkage Assembly 1 or 2

251XXX - Disk Gang Assembly #

B1 - Beam Mount 1 (251657 x5)

B2 - Beam Mount 2 (251650 x3)

B3 - Beam Mount 3 (251414 x1)

B4 - Beam Mount 4 (251415 x1)

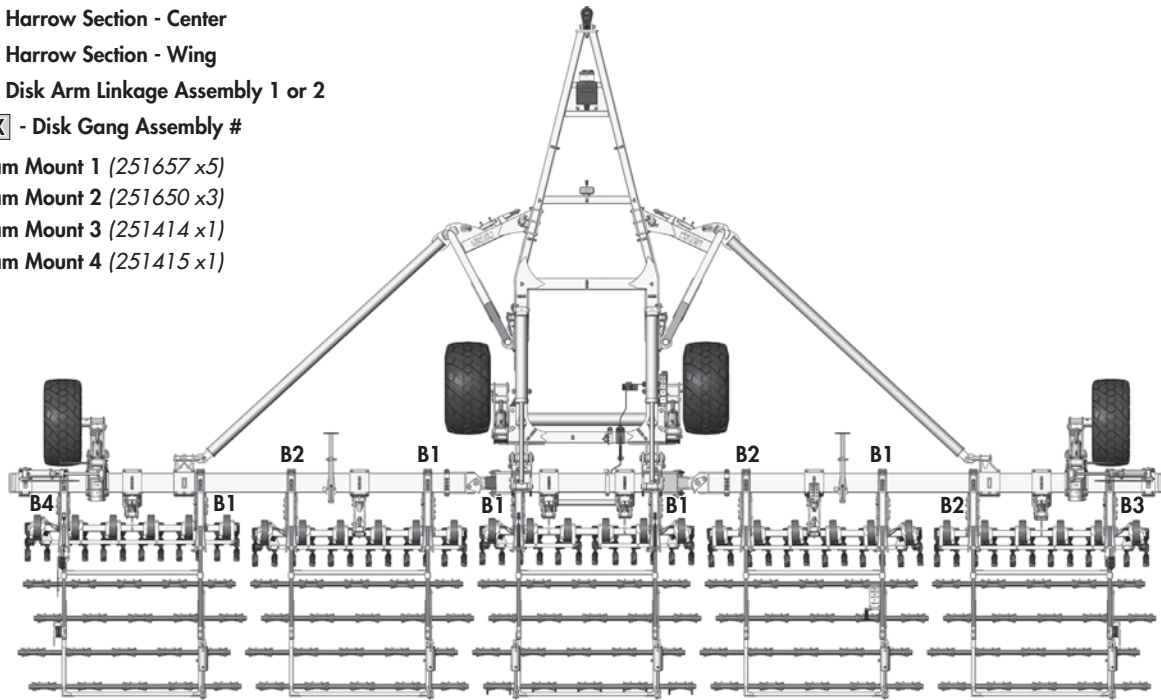

LH Wing Beam Mounting Location Overview

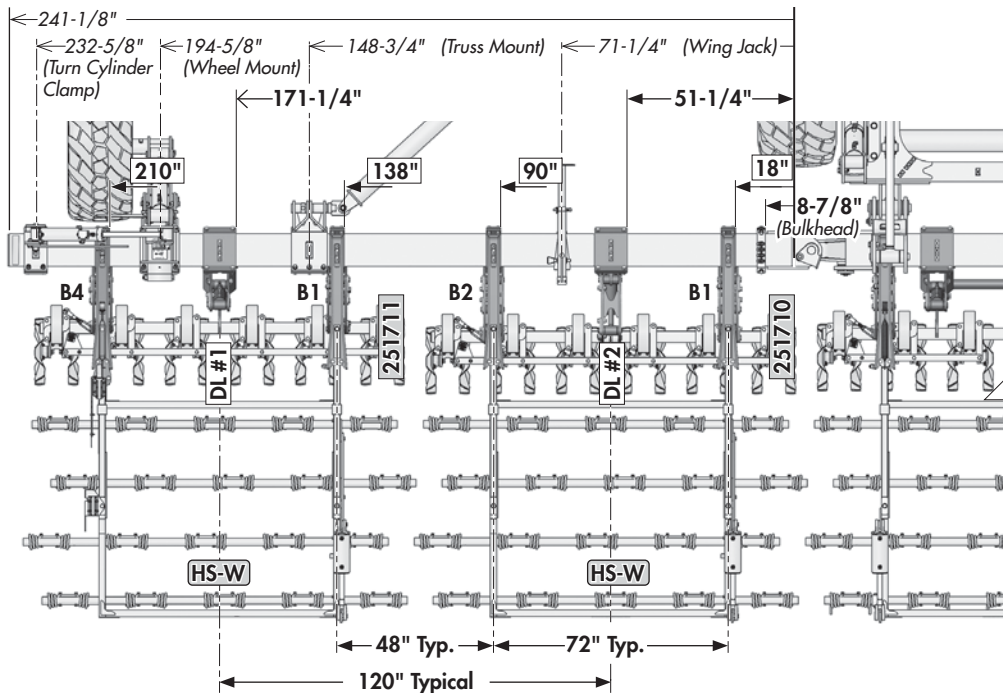

Wing/Center Beam Mount Locations

Center Section Mounting Location Overview

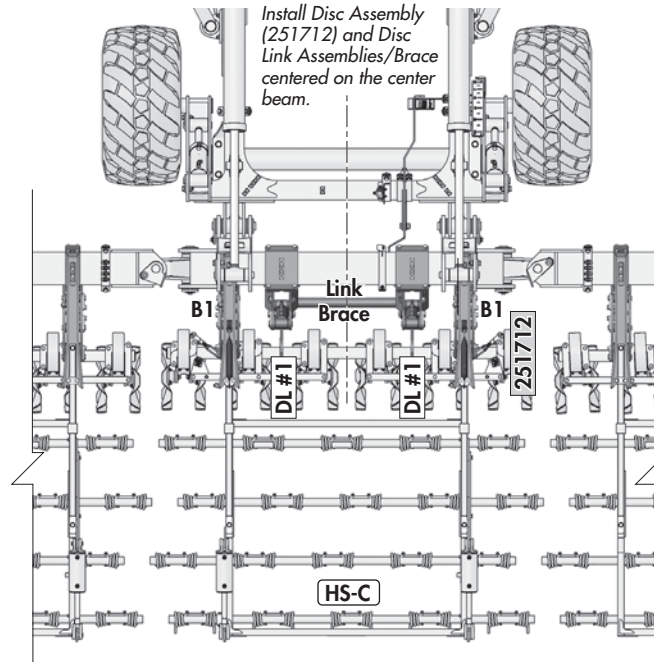

RH Wing Beam Mounting Location Overview

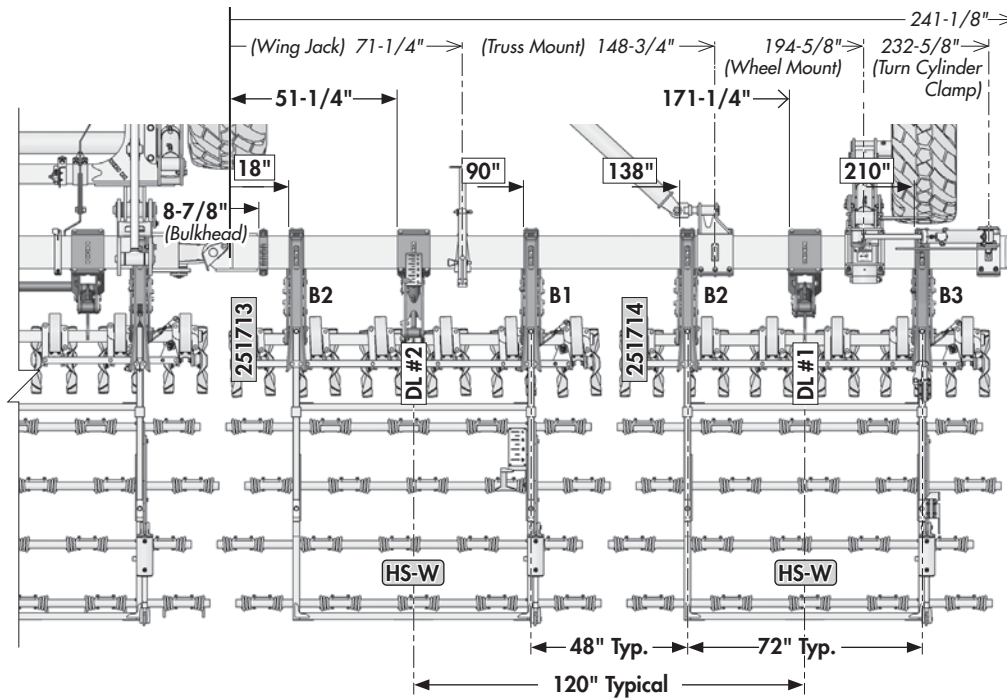

Disc Arm Linkage Components

DL #1 - Disc Arm Linkage Assembly #1 Components DL #1

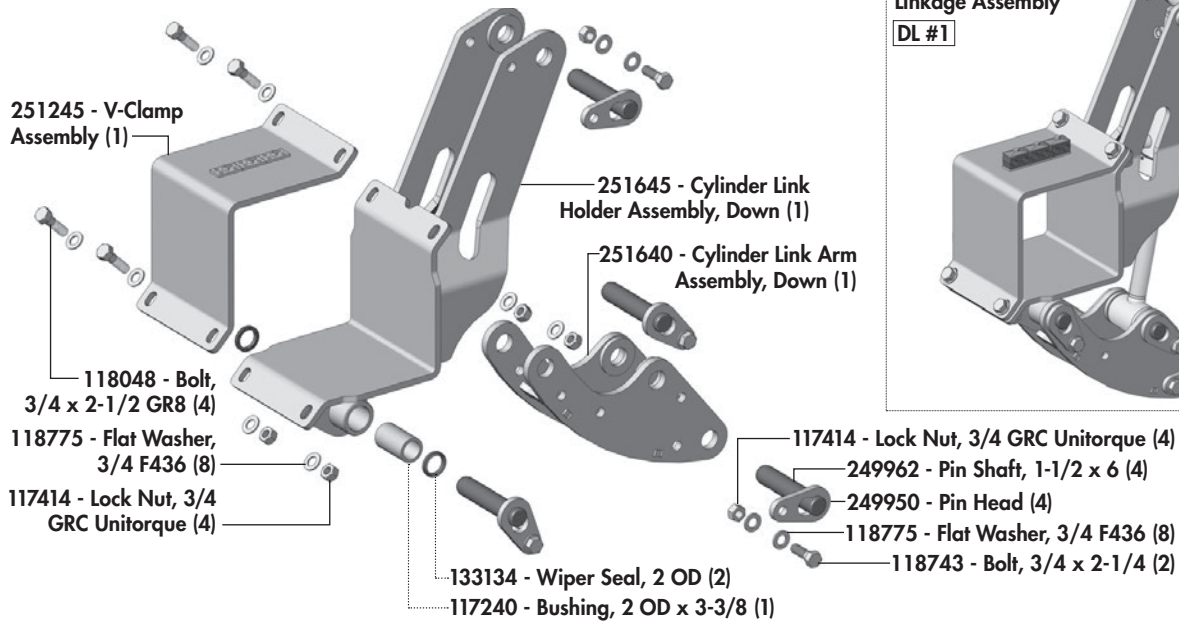

Center Section Disc Arm Linkage Assembly/Cross Beam

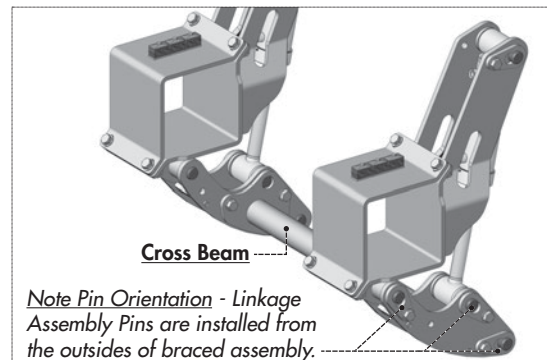
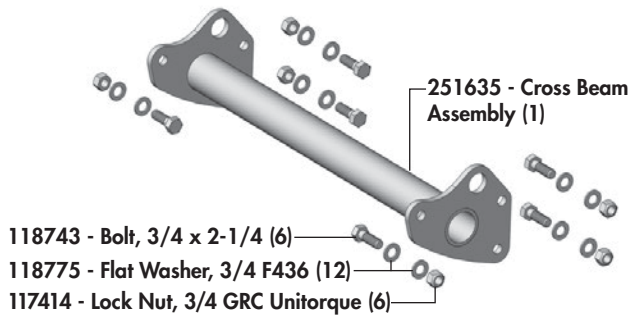

DL #2 - Disc Arm Linkage Assembly #2 Components DL #2

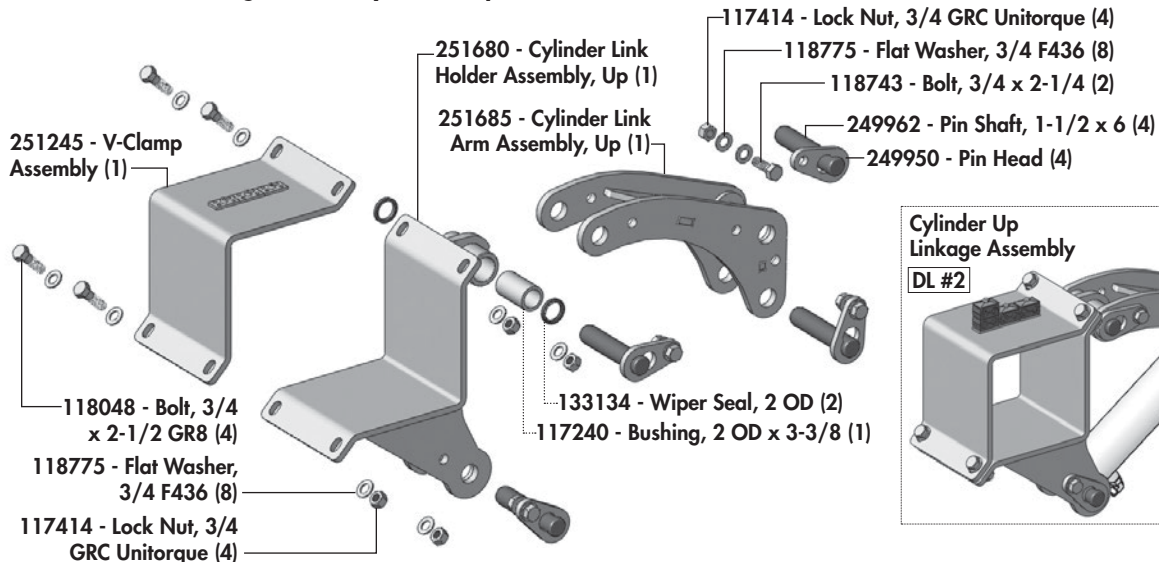

Disc Gang Assembly - Center

Cylinders Down Center - Disc Gang Overview 251712 (Center Section)

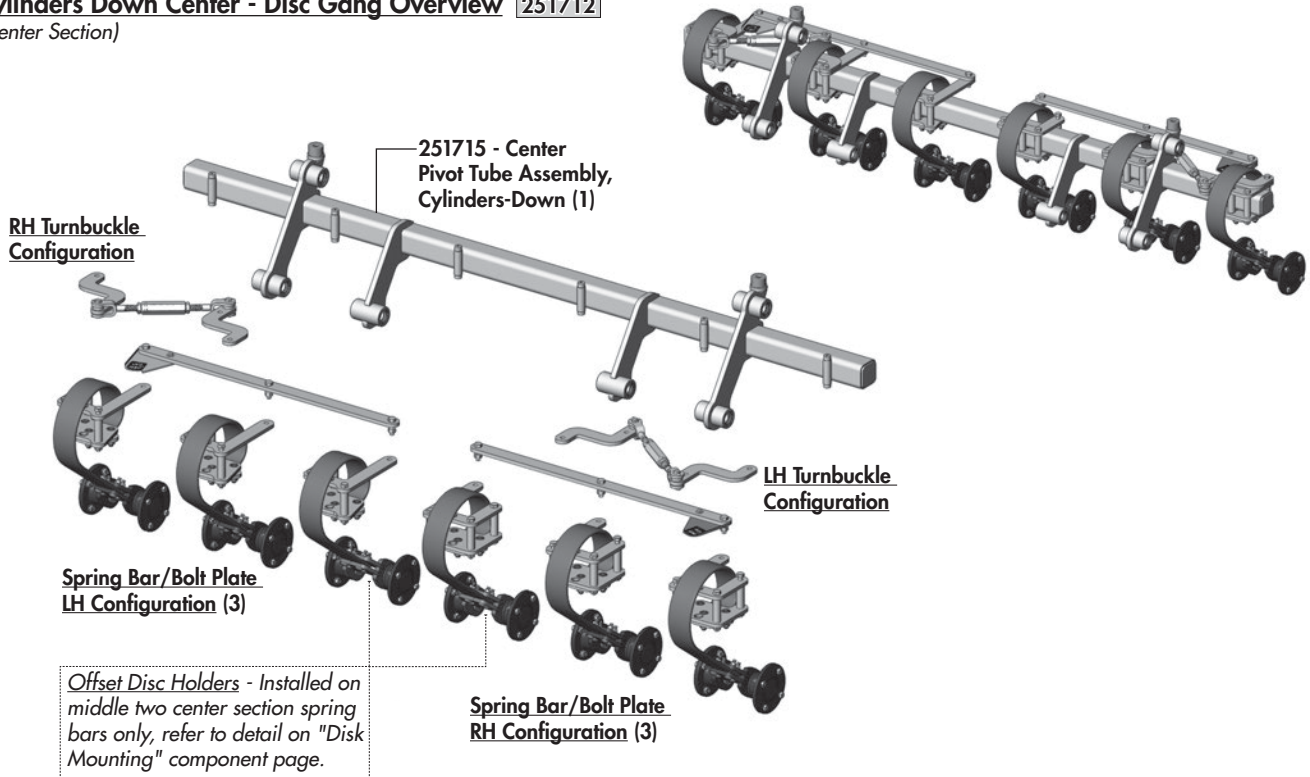

Disc Section Details (Typical Components)

RH Turnbuckle Configuration

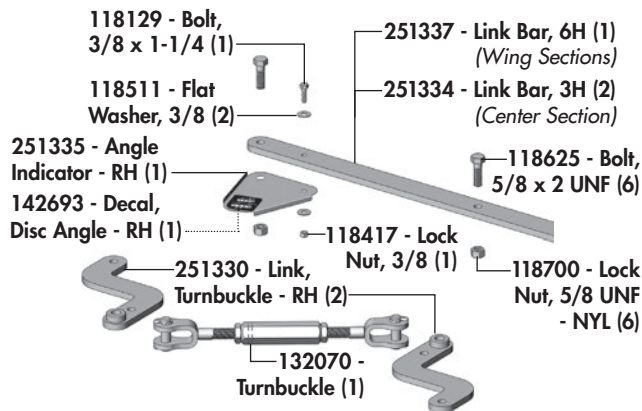

Pivot Tube Components

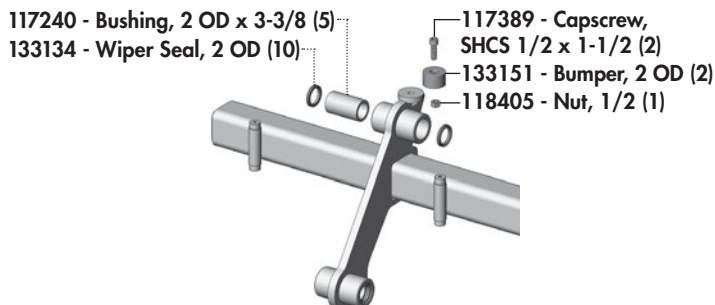

LH Turnbuckle Configuration

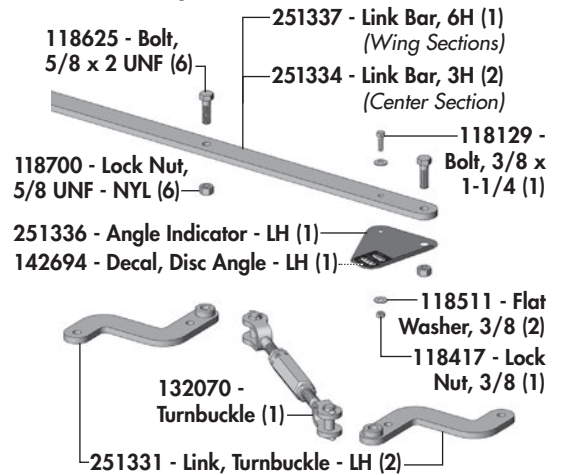

Disc Gang Assembly - LH

Cylinder Up LH - Disc Gang Overview 251710 *(LH Wing Outer and Third Section)*

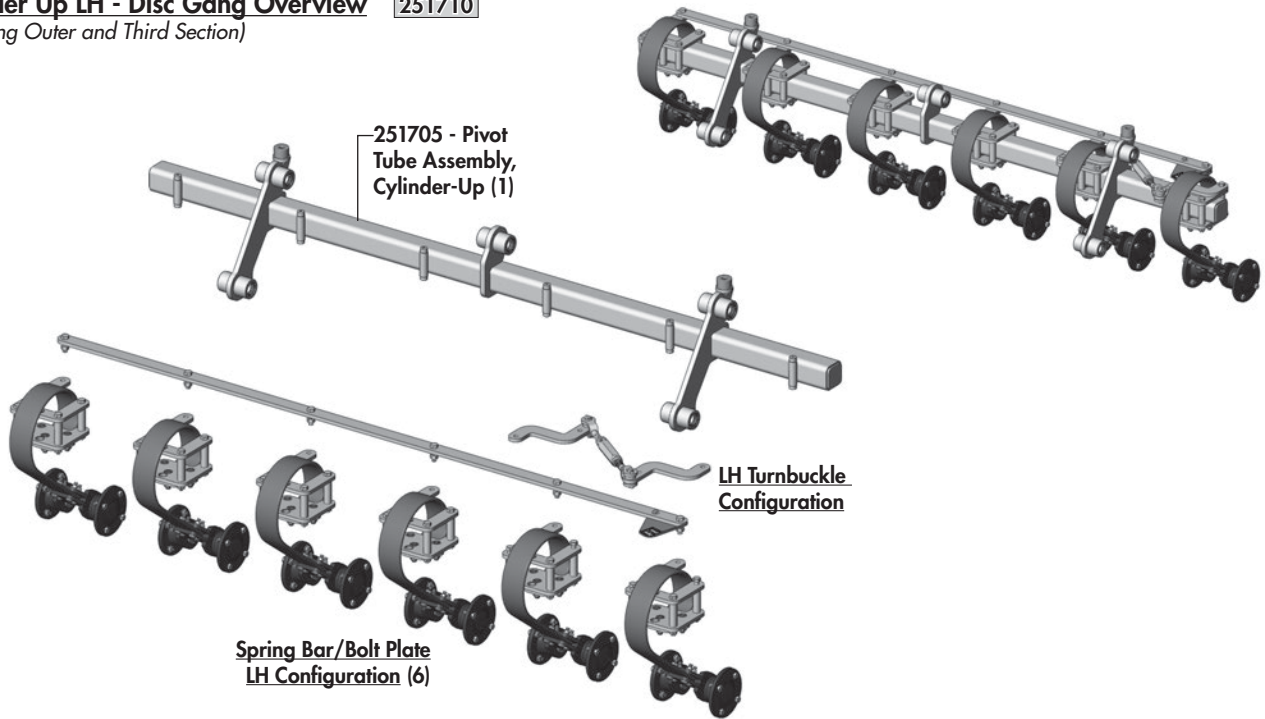

Cylinder Down LH - Disc Gang Overview 251711 *(LH Wing Second Section)*

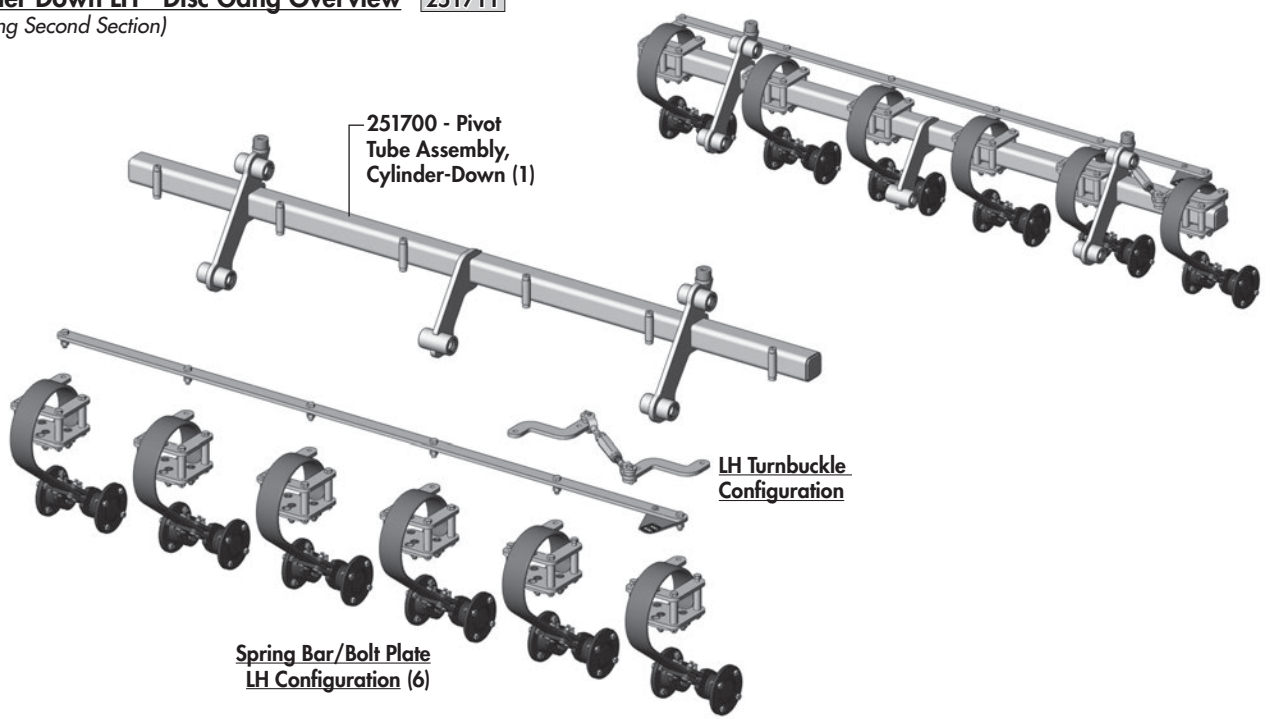

Disc Gang Assembly - RH

Cylinder Up RH - Disc Gang Overview 251713 (RH Wing Outer and Third Section)

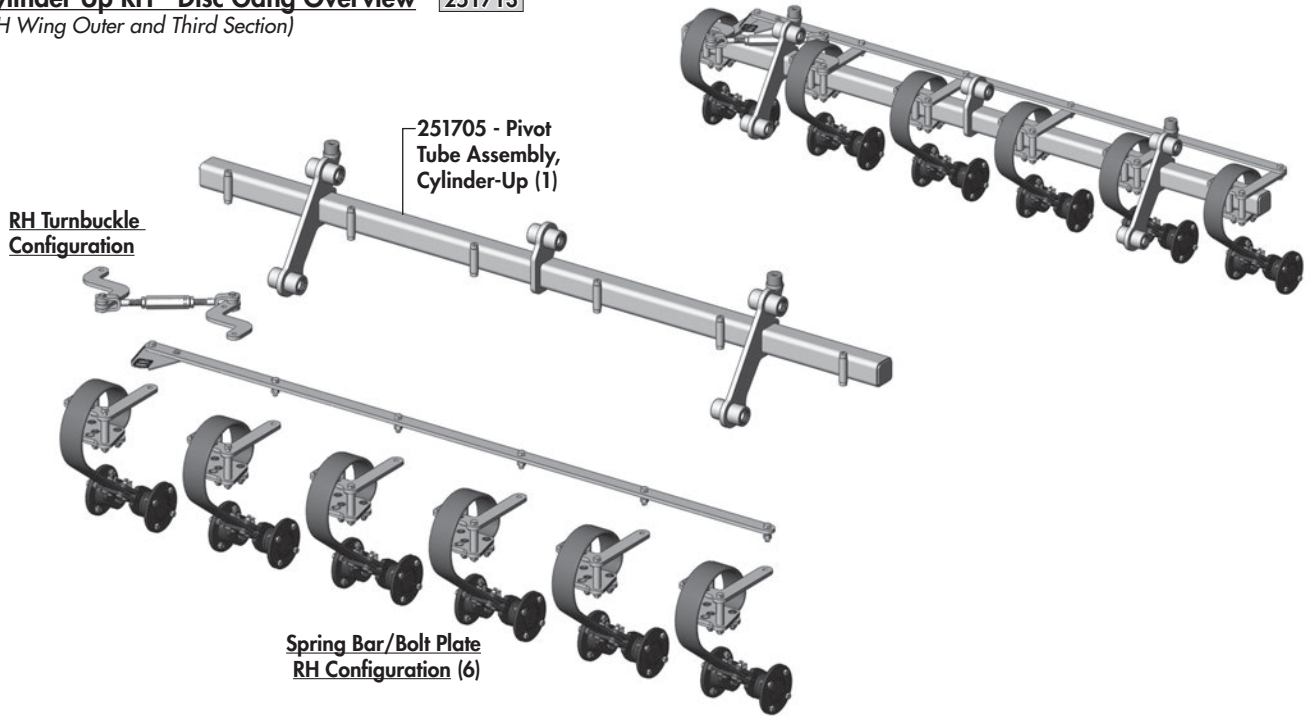

Cylinder Down RH - Disc Gang Overview 251714 (RH Wing Second Section)

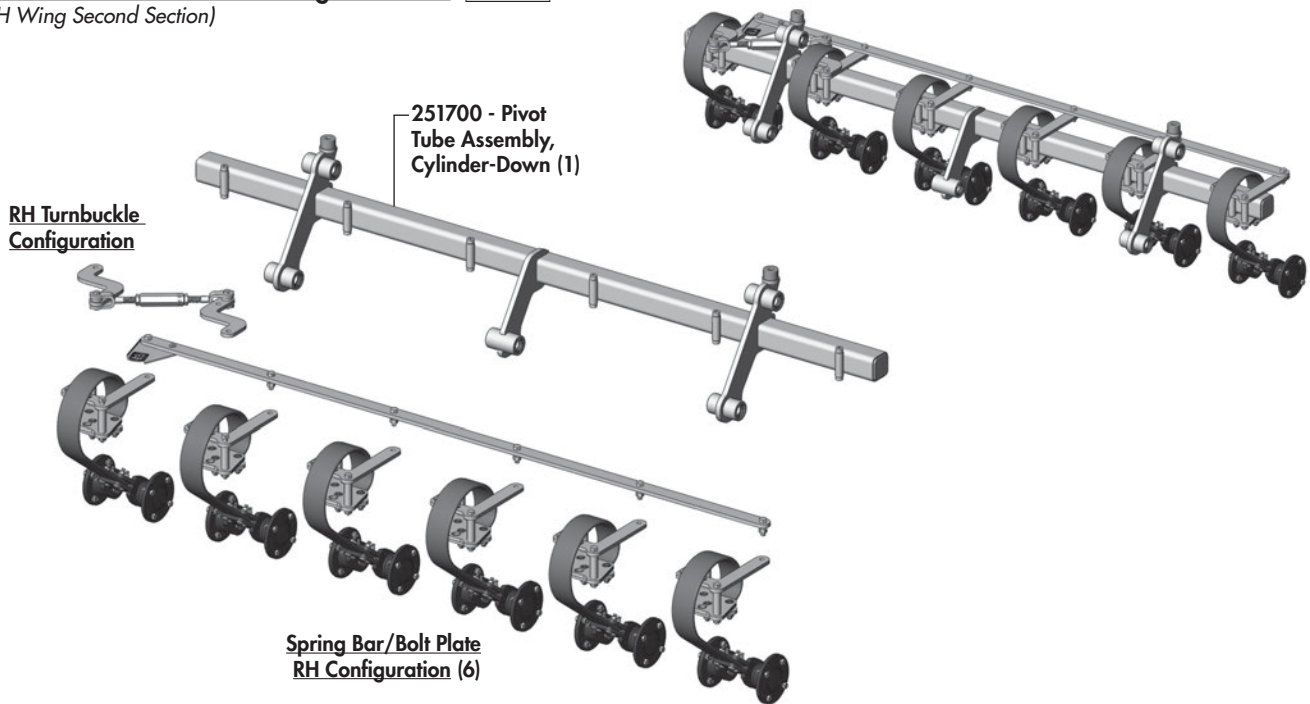

Disc Mounting Components

Spring Bar/Bolt Plate Components

(Quantities shown are numbers required for each Spring Bar)

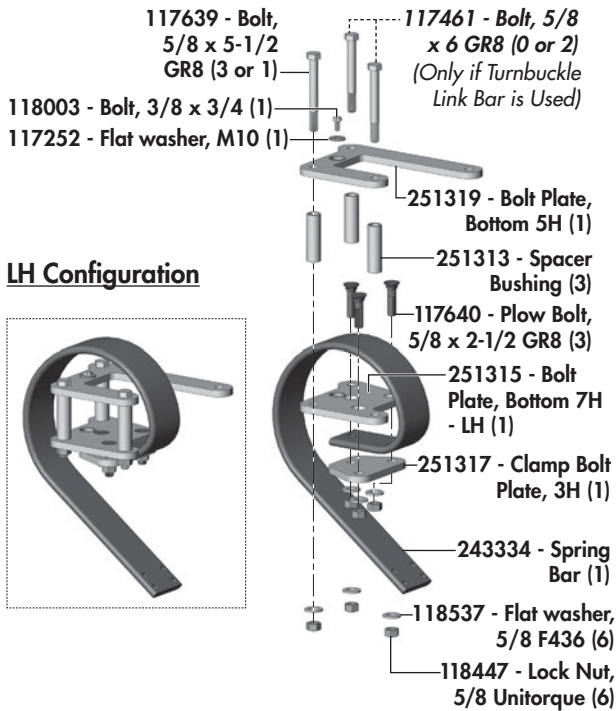

RH Configuration

(Use same items as LH unless indicated. Note: Orientation differs from LH)

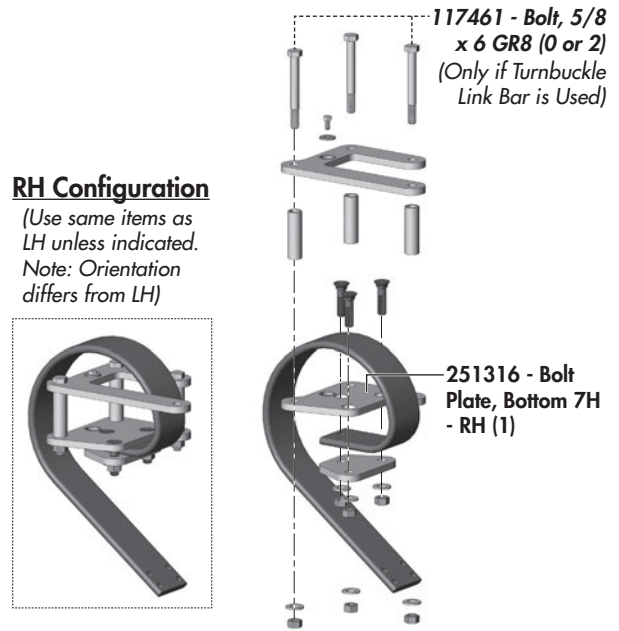

Disc Mounting Components

(Quantities shown are numbers required for each Spring Bar)

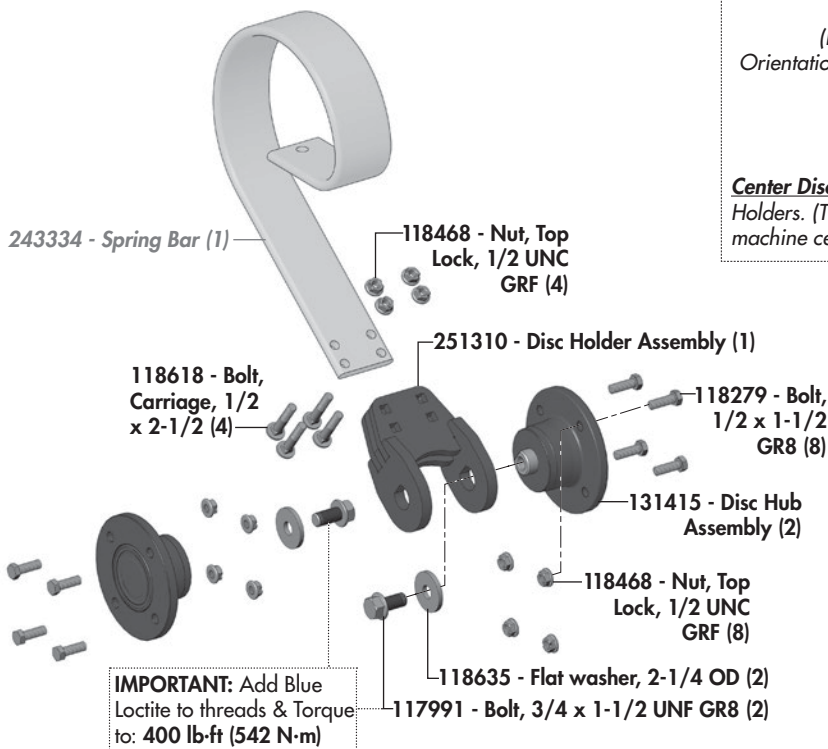

251309 - Disc Holder Assembly, w/Offset (2)

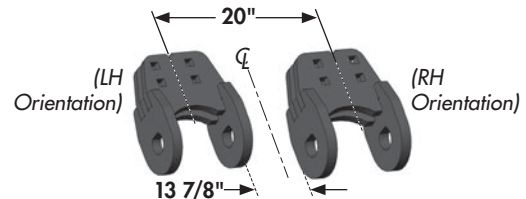

Center Disc Assembly Section Only - Middle two Disc Holders. (The offset side of disc holder positioned towards machine center, align arrow notch to center of spring bar.)

Disc Options

Disc Option Component Overview

Wave Samurai

- Good for cutting heavy trash and mixing soil while incorporating.
- Extremely aggressive edge maintains penetration and wear.
- Fluted disc allows blade to turn in heavy residue.
- 4° to 10° , can be angled more aggressively if needed.

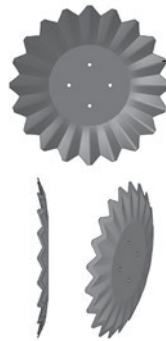

251994 - Samurai, Wave Set (60)

143499 - Samurai, Wave - 20" (1)

Wave Notched

- Good for maximum coverage and mixing soil at shallow working depth.
- 4" wave assist disc to turn in extreme conditions.
- Notches help disc penetrate and size material.
- Maintains constant cutting angle as it wears.
- 0° to 10° .



251996 - Notched, Wave Set (60)

143494 - Notched, Wave - 20" (1)

Curved Wave VT

- Good for opening ground and cutting with minimal soil disruption.
- Soil razor edge cuts aggressively with good wear characteristics.
- Curved waves allows blade to turn in heavy residue without turning soil over.
- 0° to 4° , should not be angled aggressively.

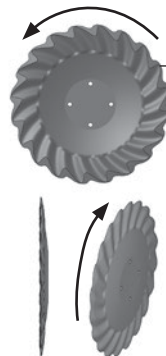

251995 - Curved VT, Wave Set (30 RH, 30 LH)

143497 - Curved VT, Wave - 20" LH (1)

143498 - Curved VT, Wave - 20" RH (1)

Flattened Double V

- Good for cutting/sizing trash and incorporating.
- Aggressive edge maintains penetration and wear.
- Double V provides a smoother furrow.
- 2° to 10° , can be used more aggressively if needed.



251997 - Double V, Flattened Set (60)

143495 - Double V, Flattened - 20" (1)

Harrow Section Components

Harrow Section - Wings

HS-W

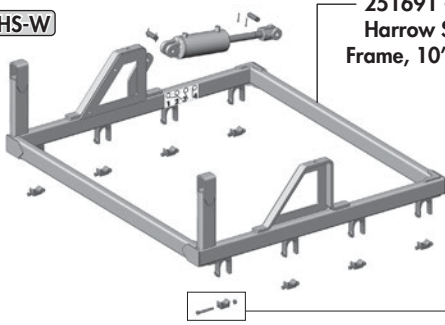

251691 - Wing Harrow Section Frame, 10' - 4 Row

Harrow Section - Center

HS-C

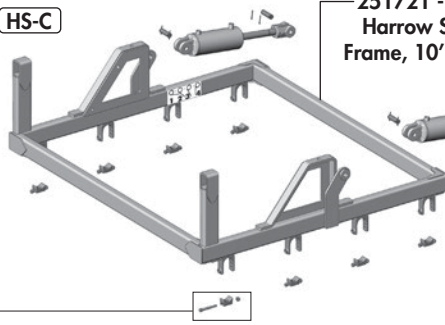

251721 - Center Harrow Section Frame, 10' - 4 Row

Note: When tightening, ensure pipe turns freely.

118126 - Bolt, 1/2 x 4 (8)

118468 - Nut, Top Lock Flange - 1/2 (8)

110050 - Pipe Spacer, CSTG (8)

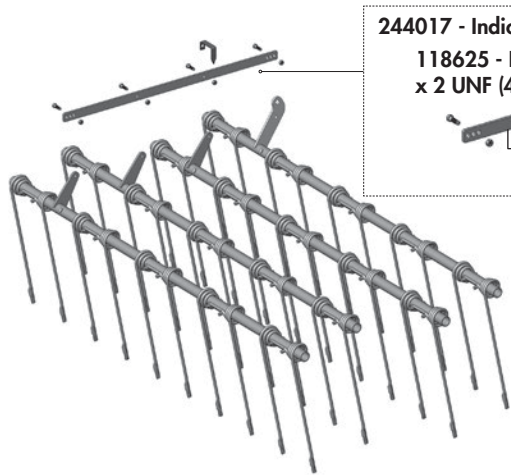

244017 - Indicator Pointer (1)

118625 - Bolt, 5/8 x 2 UNF (4)

118700 - Lock Nut, 5/8 UNF (4)

251349 - Link Bar, 8 hole (1)

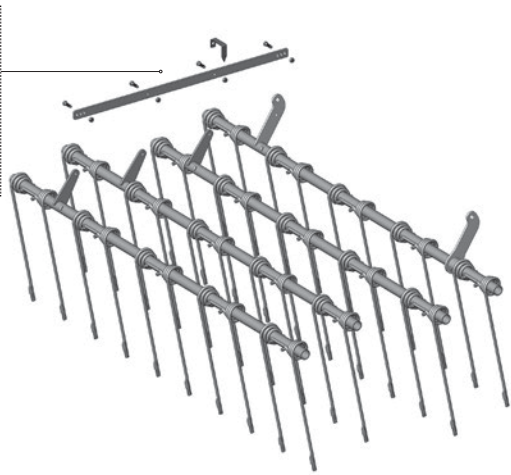

244215 - Pipe, 20-1/2" offset (1)

HS-W

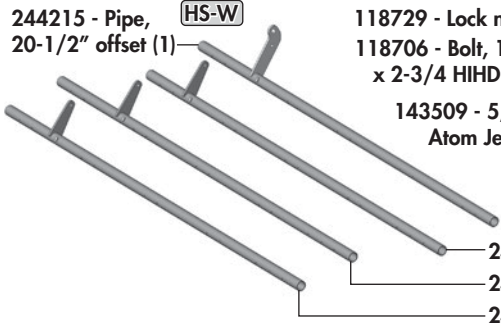

118729 - Lock nut, 1/2 (2)

118706 - Bolt, 1/2 x 2-3/4 HIHD (2)

143509 - 5/8 x 30 Atom Jet Tip (1)

(10' Section - 20 tines)

244214 - Pipe, 14-3/4" offset (1)

244213 - Pipe, 23-1/4" offset (1)

244212 - Pipe, 17-1/2" offset (1)

244899 - Pipe, 20-1/2" offset (1)

HS-C

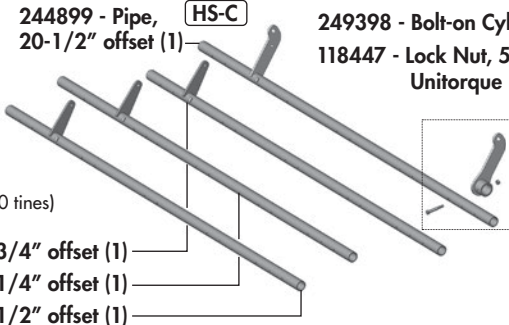

249398 - Bolt-on Cylinder Lug (1)

118447 - Lock Nut, 5/8 Unitorque (1)

118094 - Bolt, 5/8 x 4 GR8 (1)

Harrow Section Components

Harrow Spring Bar Assembly Components (2 per Harrow Section)

- 251226 - Bungee Bracket (2)
- 133149 - Bungee, Spring (2)
- 133150 - Tie Cable (2)
- 118094 - Bolt, 5/8 x 4 GR8 (2)
- 650250 - Cast Shank Bolt Bar (1)
(Flat side faces up)
- 243339 - Bar, Spring Steel (1)
- 118054 - Bolt, 3/4 x 3-1/2 GR8 (1)
- (Center Section Only)
- 118056 - Bolt, 3/4 x 4 GR8 (1)
- 118775 - Flat Washer, 3/4 F436 (4)
- 243061 - Bar, Back-up (1)
- 117414 - Lock Nut, 3/4 Unitorque (2)

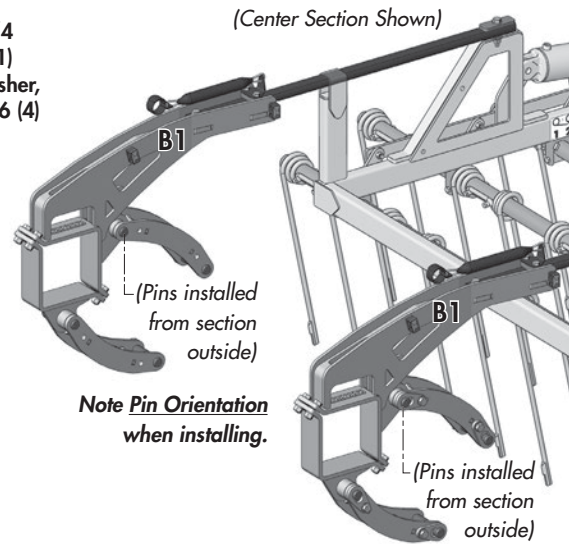

Refer to "Wing/Center Beam Mount Locations" page for spring bar assembly "B1/B2/B3/B4 - Beam Mount" locations.

B1 Spring Bar Assembly (251657) -with Hydraulic Clamps

- 251657 - Spring Bar Extension Assembly (8)
- 118048 - Bolt, 3/4 x 2-1/2 GR8 (4)
- 118775 - Flat Washer, 3/4 F436 (8)
- 117414 - Lock Nut, 3/4 Unitorque (4)
- 251660 - Clamp Plate (1)
- 117240 - Bushing, 2 OD x 3-3/8 (2)
- 133134 - Wiper Seal, 2 OD (4)
- 118537 - Flat Washer, 5/8 - F436 (4)
- 118447 - Lock Nut, 5/8 Unitorq (2)
- 251665 - Parallel Link Assembly (2)
- 249950 - Pin Head (4)
- 249962 - Pin Shaft, 1-1/2 x 6 (4) mounts with...
- 118743 - Bolt, 3/4 x 2-1/4 (2)
- 118775 - Flat Washer, 3/4 F436 (8)
- 117414 - Lock Nut, 3/4 GRC Unitorq (4)

B2 Spring Bar Assembly (251650) Same as B1 -without Hydraulic Clamps

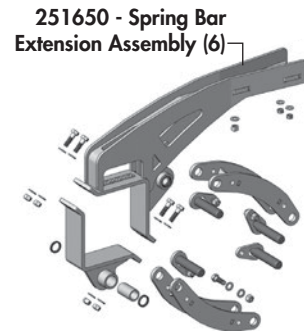

Hose Clamp Parts A

- 118317 - Bolt, 5/16 x 1-3/8 (2)
- 780279 - Top Plate (2)
- 780346 - Hose Clamp, 2 Halves (2)

B3 Spring Bar Assembly (251414) -with Hydraulic Clamps

- 251414 - Spring Bar Extension Assembly (8)
- 118048 - Bolt, 3/4 x 2-1/2 GR8 (4)
- 118775 - Flat Washer, 3/4 F436 (8)
- 117414 - Lock Nut, 3/4 Unitorque (4)
- 251660 - Clamp Plate (1)
- 117240 - Bushing, 2 OD x 3-3/8 (2)
- 133134 - Wiper Seal, 2 OD (4)
- 118537 - Flat Washer, 5/8 - F436 (4)
- 118447 - Lock Nut, 5/8 Unitorq (2)
- 251665 - Parallel Link Assembly (2)
- 249962 - Pin Shaft, 1-1/2 x 6 (4)
- 249950 - Pin Head (4) mounts with...
- 118743 - Bolt, 3/4 x 2-1/4 (2)
- 118775 - Flat Washer, 3/4 F436 (8)
- 117414 - Lock Nut, 3/4 GRC Unitorq (4)

B4 Spring Bar Assembly (251415) Same as B3 -without Hydraulic Clamps

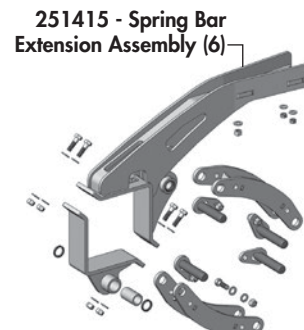

Wing Section Components

Indicator Assembly Components

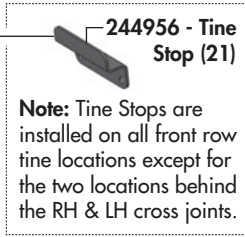
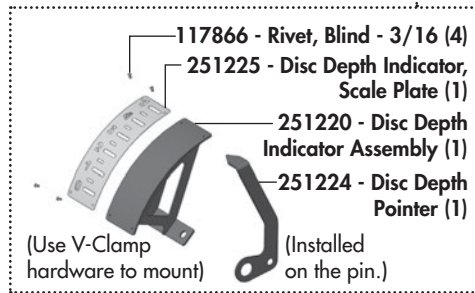
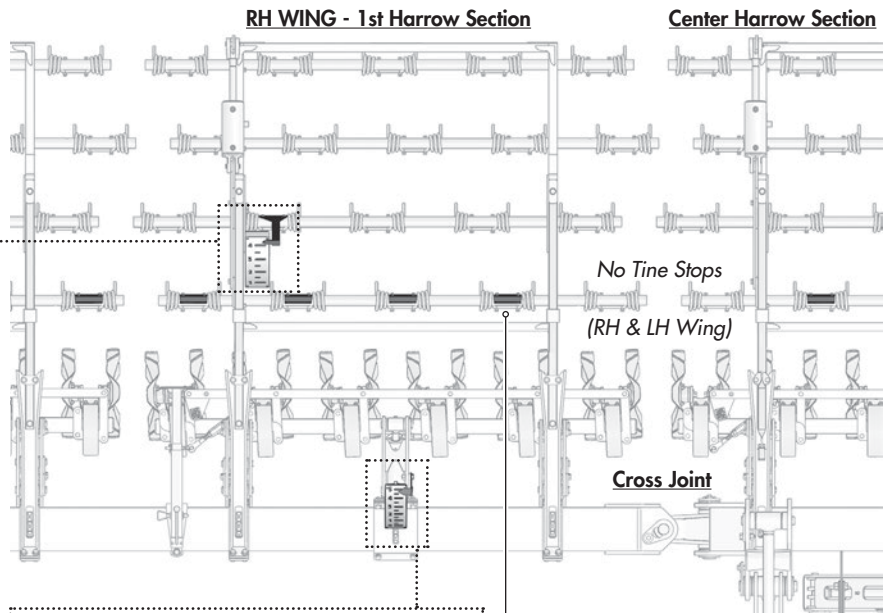
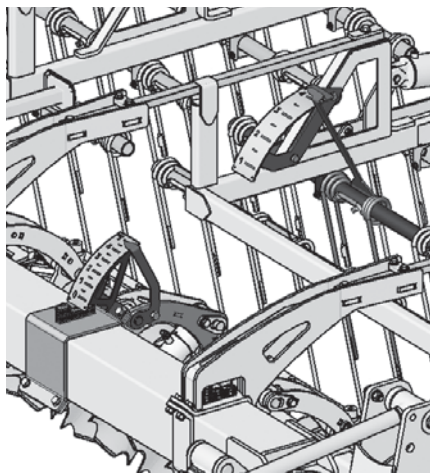
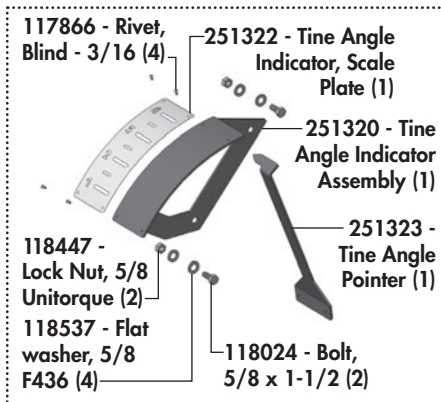

Hose Clamp Locations

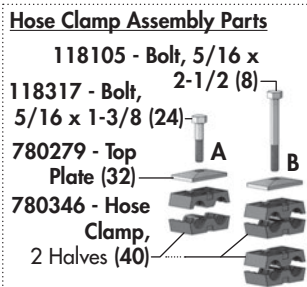

RH Wing

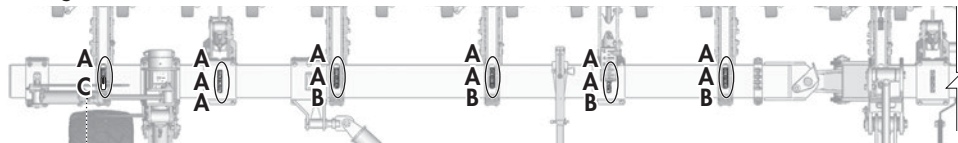

Center Frame - (No Hose Clamps)

Endwheel Lock Holder

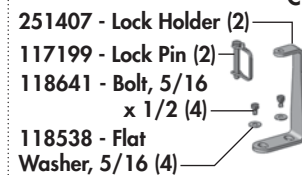

LH Wing

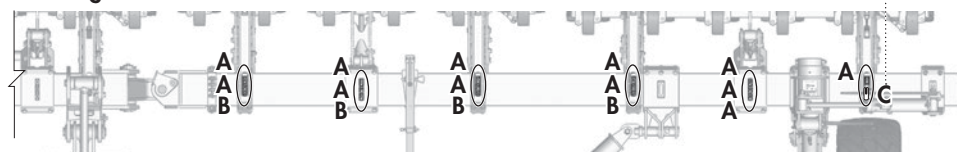

Hydraulic Layout - Wheels

Hydraulic Fittings Required

- | | | | |
|---|--|--|-----|
| 1 | | 141581 - Coupler Tip, 3/4 ORB F | (2) |
| 2 | | 141830 - Coupler, Green (+) | (1) |
| 3 | | 141831 - Coupler, Green (-) | (1) |
| 4 | | 141703 - Adaptor, 1/2 ORB M x ORFS M | (2) |
| 5 | | 141754 - Connector, 1/2 ORFS M x M | (8) |
| 6 | | 141704 - Elbow, 90° 1/2 ORB M x ORFS M | (8) |
| 7 | | 141706 - Tee, 1/2 ORFS M x M x M | (2) |

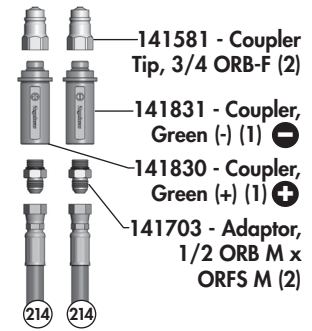

Required Hoses for Wheel Cylinders

Hoses, 3/8 - 1/2 ORFS F-SW

- (242) 126179 - Hose, 3/8 x 242 (2)
- (214) 126866 - Hose, 3/8 x 214 (2)
- (132) 126190 - Hose, 3/8 x 132 (4)
- (120) 126877 - Hose, 3/8 x 120 (2)
- (55) 126163 - Hose, 3/8 x 55 (2)
- (26) 126162 - Hose, 3/8 x 26 (2)

Hoses, 3/8 - 1/2 ORFS F-SW x F-90°

- (238) 126178 - Hose, 3/8 x 238 (2)

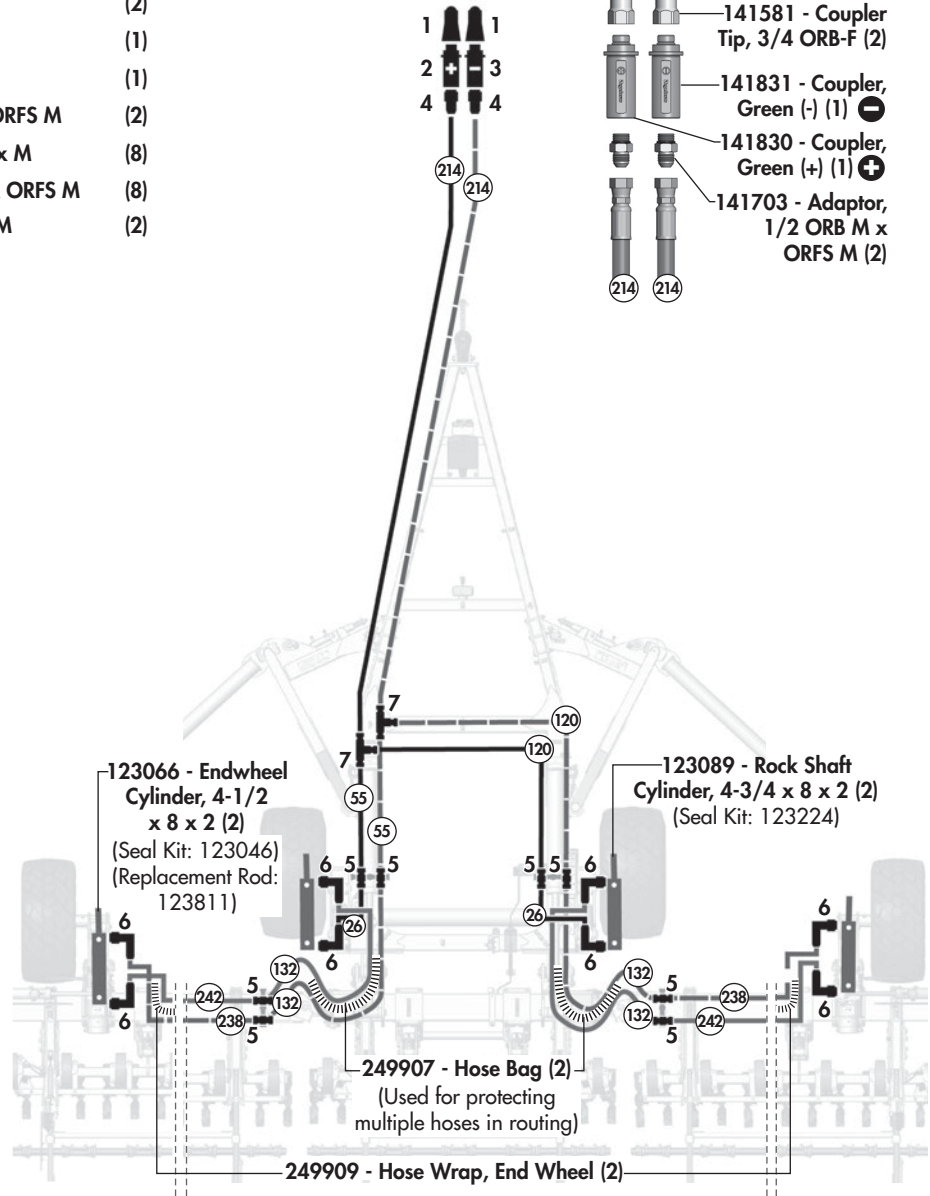

Center Beam Hose Routing Reference

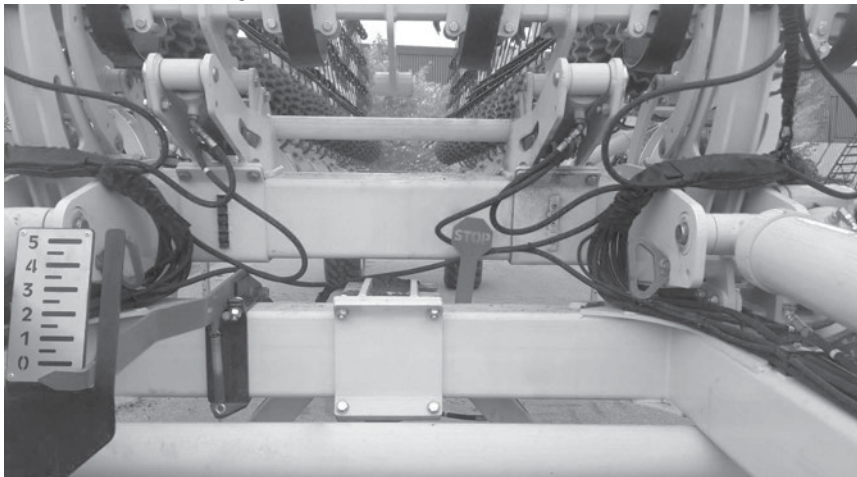



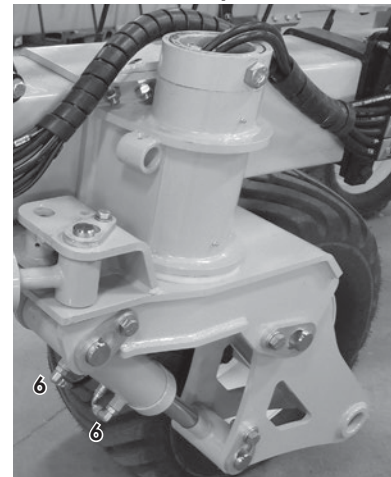



RH Endwheel Assembly



Hydraulic Layout - Transport

Hydraulic Fittings Required

- 1  141581 - Coupler Tip, 3/4 ORB F (2)
- 2  141832 - Coupler, Blue (+) (1)
- 3  141833 - Coupler, Blue (-) (1)
- 4  141703 - Adaptor, 1/2 ORB M x ORFS M (2)
- 5  141706 - Tee, 1/2 ORFS M x M x M (2)
- 6  141704 - Elbow, 90° 1/2 ORB M x ORFS M (4)

Required Hoses for Transport Cylinders

Hoses, 3/8 - 1/2 ORFS F-SW





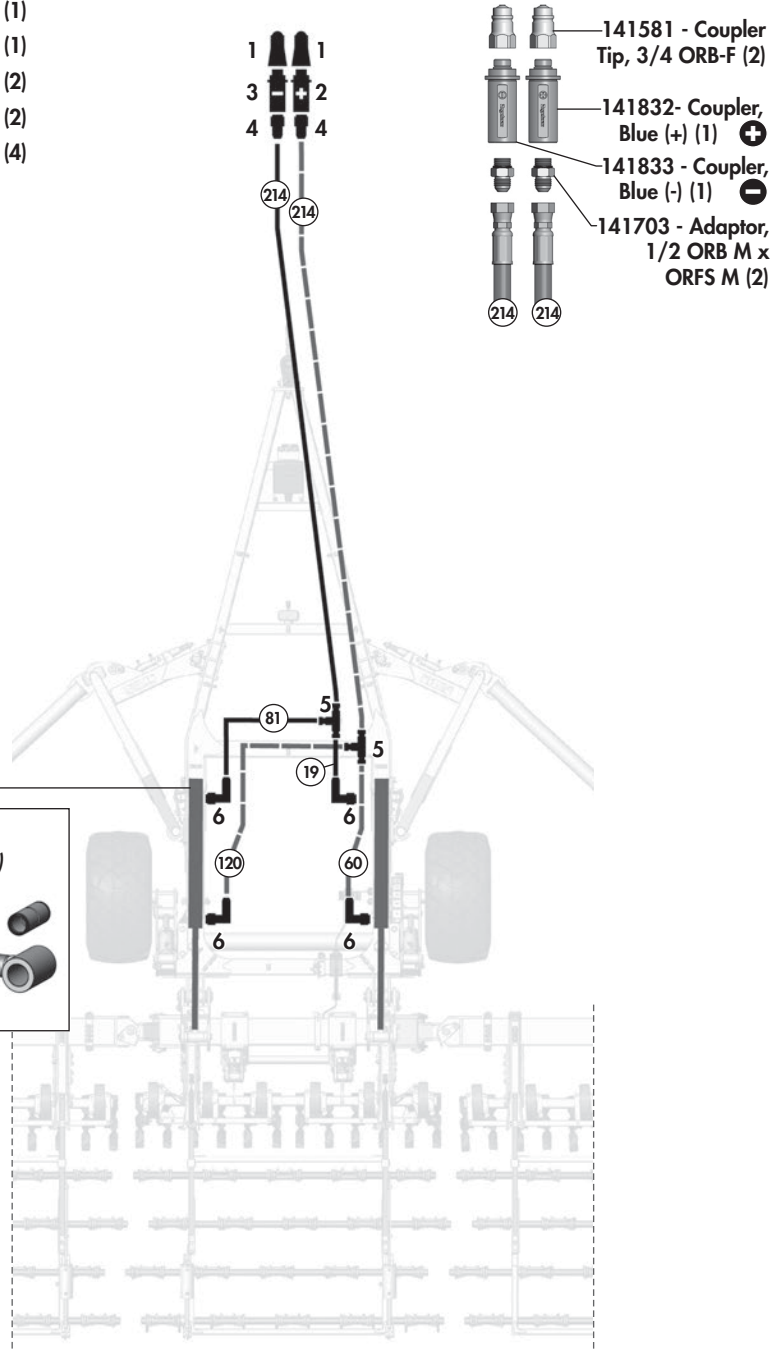
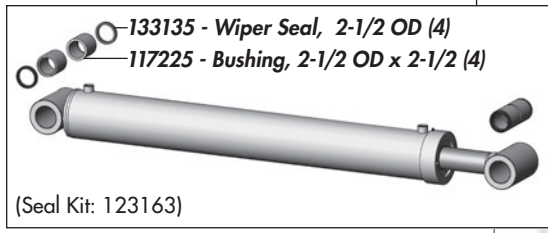



- (214) 126866 - Hose, 3/8 x 214 (2)
- (120) 126877 - Hose, 3/8 x 120 (1)
- (81) 126876 - Hose, 3/8 x 81 (1)
- (60) 126879 - Hose, 3/8 x 60 (1)
- (19) 126878 - Hose, 3/8 x 19 (1)

123053 - Cylinder, Monarch - 6 x 40 x 2-1/2 (2)



Hydraulic Layout - DOC

Hydraulic Fittings Required

- 1  141581 - Coupler Tip, 3/4 ORB F (2)
- 2  141834 - Coupler, Brown (+) (1)
- 3  141835 - Coupler, Brown (-) (1)
- 4  141703 - Adaptor, 1/2 ORB M x ORFS M (2)
- 5  141754 - Connector, 1/2 ORFS M x M (8)
- 6  141704 - Elbow, 90° 1/2 ORB M x ORFS M (8)
- 7  141706 - Tee, 1/2 ORFS M x M x M (2)
- 8  141739 - Elbow, 45° 1/2 ORB M x ORFS M (4)

Required Hoses for Disc-On-Command Cylinders

Hoses, 3/8 - 1/2 ORFS F-SW

- 183 126175 - Hose, 3/8 x 183 (2)
- 171 126174 - Hose, 3/8 x 171 (2)
- 156 126944 - Hose, 3/8 x 156 (2)
- 149 126170 - Hose, 3/8 x 149 (2)
- 132 126190 - Hose, 3/8 x 132 (2)
- 102 126167 - Hose, 3/8 x 102 (2)
- 100 126166 - Hose, 3/8 x 100 (2)
- 80 126165 - Hose, 3/8 x 80 (2)
- 70 126164 - Hose, 3/8 x 70 (2)

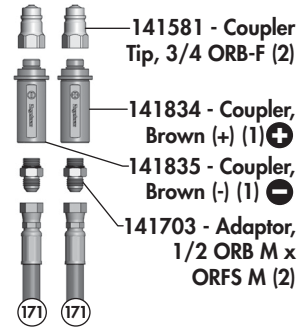

IMPORTANT: To ensure optimum performance, all entrapped air must be purged from the rephasing cylinder systems frequently. Follow the "Rephasing the Cylinder Circuits" procedure.

IMPORTANT: Ensure Hydraulic Hoses are safely routed and secured on the outside of all harrow sections as to avoid "rubbing" against any components and causing wear issues.

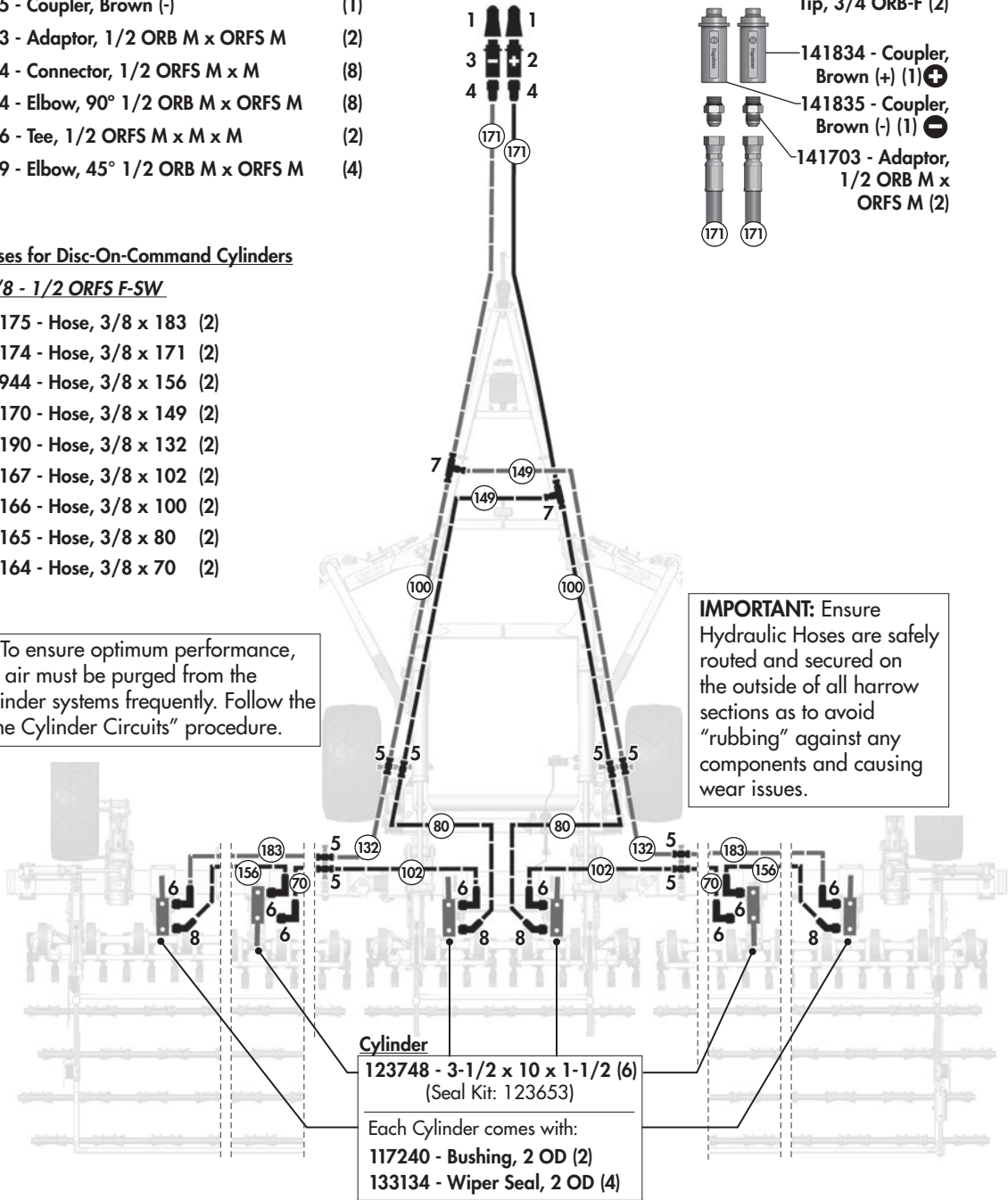

Hydraulic Layout - Tine Angle

Hydraulic Fittings Required

- 1 141581 - Coupler Tip, 3/4 ORB F (2)
- 2 141836 - Coupler, Black (+) (1)
- 3 141837 - Coupler, Black (-) (1)
- 4 141703 - Adaptor, 1/2 ORB M x ORFS M (2)
- 5 141754 - Connector, 1/2 ORFS M x M (8)
- 6 141704 - Elbow, 90° 1/2 ORB M x ORFS M (12)
- 7 141706 - Tee, 1/2 ORFS M x M x M (2)

Required Hoses for Tine Angle Cylinders

Hoses, 3/8 - 1/2 ORFS F-SW

- 307 126954 - Hose, 3/8 x 307 (2)
- 295 126180 - Hose, 3/8 x 295 (1)
- 214 126866 - Hose, 3/8 x 214 (2)
- 230 126176 - Hose, 3/8 x 230 (1)
- 185 126189 - Hose, 3/8 x 185 (1)
- 180 126839 - Hose, 3/8 x 180 (2)
- 163 126171 - Hose, 3/8 x 163 (2)
- 132 126190 - Hose, 3/8 x 132 (2)
- 120 126877 - Hose, 3/8 x 120 (3)
- 55 126163 - Hose, 3/8 x 55 (2)





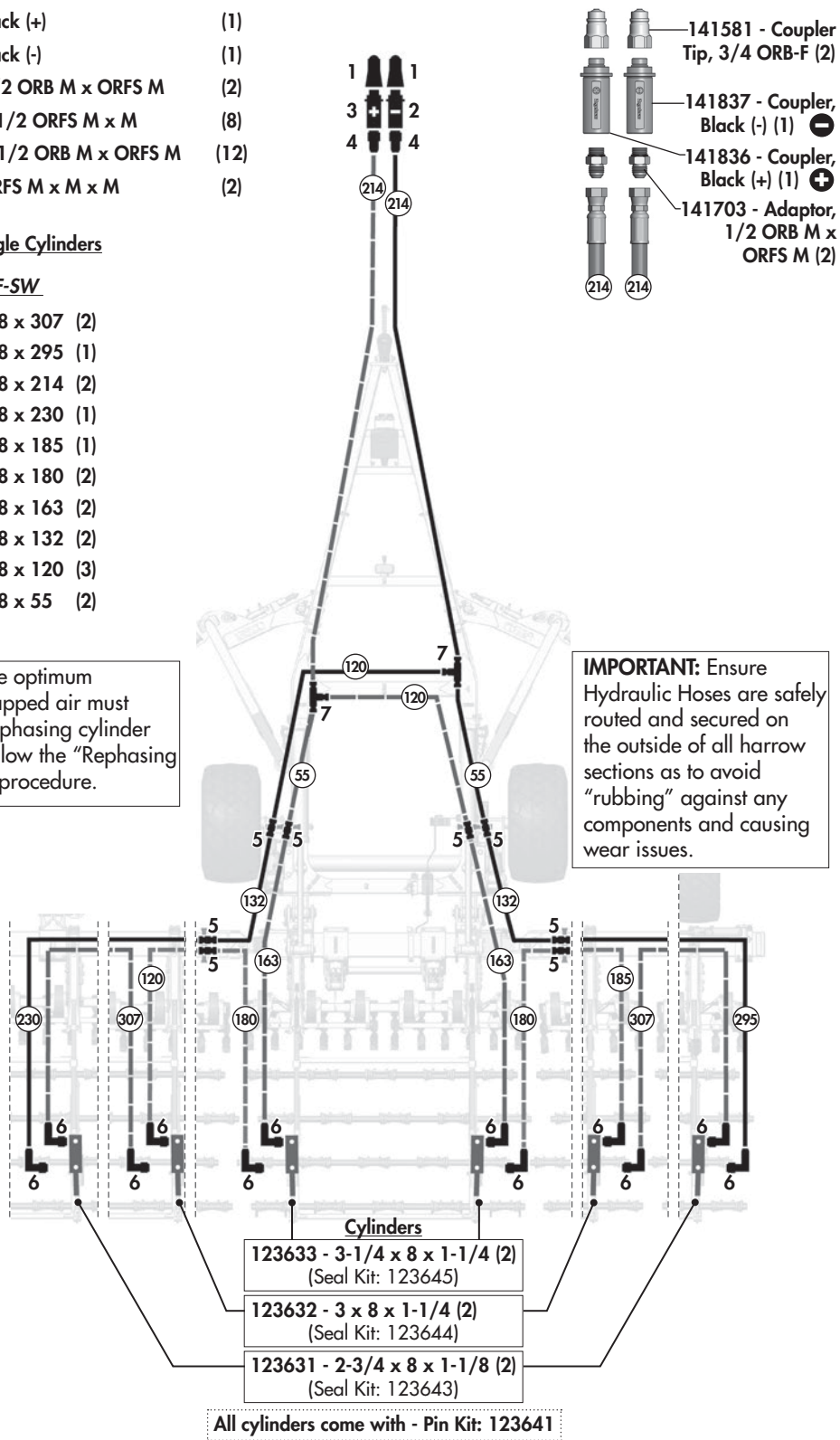







IMPORTANT: To ensure optimum performance, all entrapped air must be purged from the rephasing cylinder systems frequently. Follow the "Rephasing the Cylinder Circuits" procedure.

IMPORTANT: Ensure Hydraulic Hoses are safely routed and secured on the outside of all harrow sections as to avoid "rubbing" against any components and causing wear issues.







Hydraulic Layout - Latch & Endwheel Steering

Hydraulic Fittings Required

- 1  141581 - Coupler Tip, 3/4 ORB F (2)
- 2  141838 - Coupler, Grey (+) (1)
- 3  141839 - Coupler, Grey (-) (1)
- 4  141703 - Adaptor, 1/2 ORB M x ORFS M (5)
- 5  141754 - Connector, 1/2 ORFS M x M (8)
- 6  141704 - Elbow, 90° 1/2 ORB M x ORFS M (5)
- 7  141706 - Tee, 1/2 ORFS M x M x M (3)
- 8  141707 - Tee, 1/2 ORFS M x M x 1/2 ORB M-adj (4)
- 9  141727 - Tee, 1/2 ORFS M x F-SW x M (2)
- 10  141699 - Adaptor, 3/8 ORB M x 1/2 ORB F (2)
- 11  141728 - Tee, 1/2 ORFS M x M x F-SW (1)
- 12  141711 - Elbow, 90° 1/2 ORFS X 9/16 ORB M (6)
- 13  141735 - Hydraulic Check Valve (4)

Valves mount with...

- 118121 - Bolt, 5/16 x 2 (2)
- 118538 - Flat washer, 5/16 (4)
- 118718 - Lock Nut, 5/16 (2)

- 14  248385 - Plug, 1/2 ORB M (1)
- 15  248362 - Hydraulic Float Valve (1)
- 16  141731 - 90° Elbow, 3/4 ORB M x M (2)
- 17  141715 - Elbow, 90° 1/2 ORFS F-SW x ORFS M (2)

Required Hoses for Latch & Steering Cylinders

Hoses, 3/8 - 1/2 ORFS F-SW

- ③42 126185 - Hose, 3/8 x 342 (1)
- ②35 126177 - Hose, 3/8 x 235 (4)
- ①71 126174 - Hose, 3/8 x 171 (1)
- ①32 126190 - Hose, 3/8 x 132 (4)
- ①20 126877 - Hose, 3/8 x 120 (2)
- ①16 126168 - Hose, 3/8 x 116 (1)
- ⑤5 126163 - Hose, 3/8 x 55 (2)
- ③2 126899 - Hose, 3/8 x 32 (1)
- ②6 126161 - Hose, 3/8 x 26 (1)
- ②5 126865 - Hose, 3/8 x 25 (4)

Hoses, 3/8 - 1/2 ORFS F-SW x F-90°

- ⑥6 126936 - Hose, 3/8 x 66 (2)
- ①6 126937 - Hose, 3/8 x 16 (1)
- ①2 126910 - Hose, 3/8 x 12 (2)

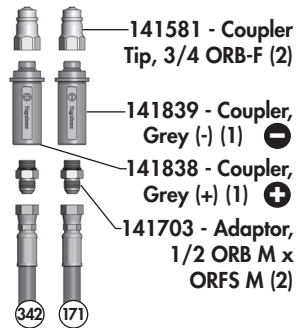
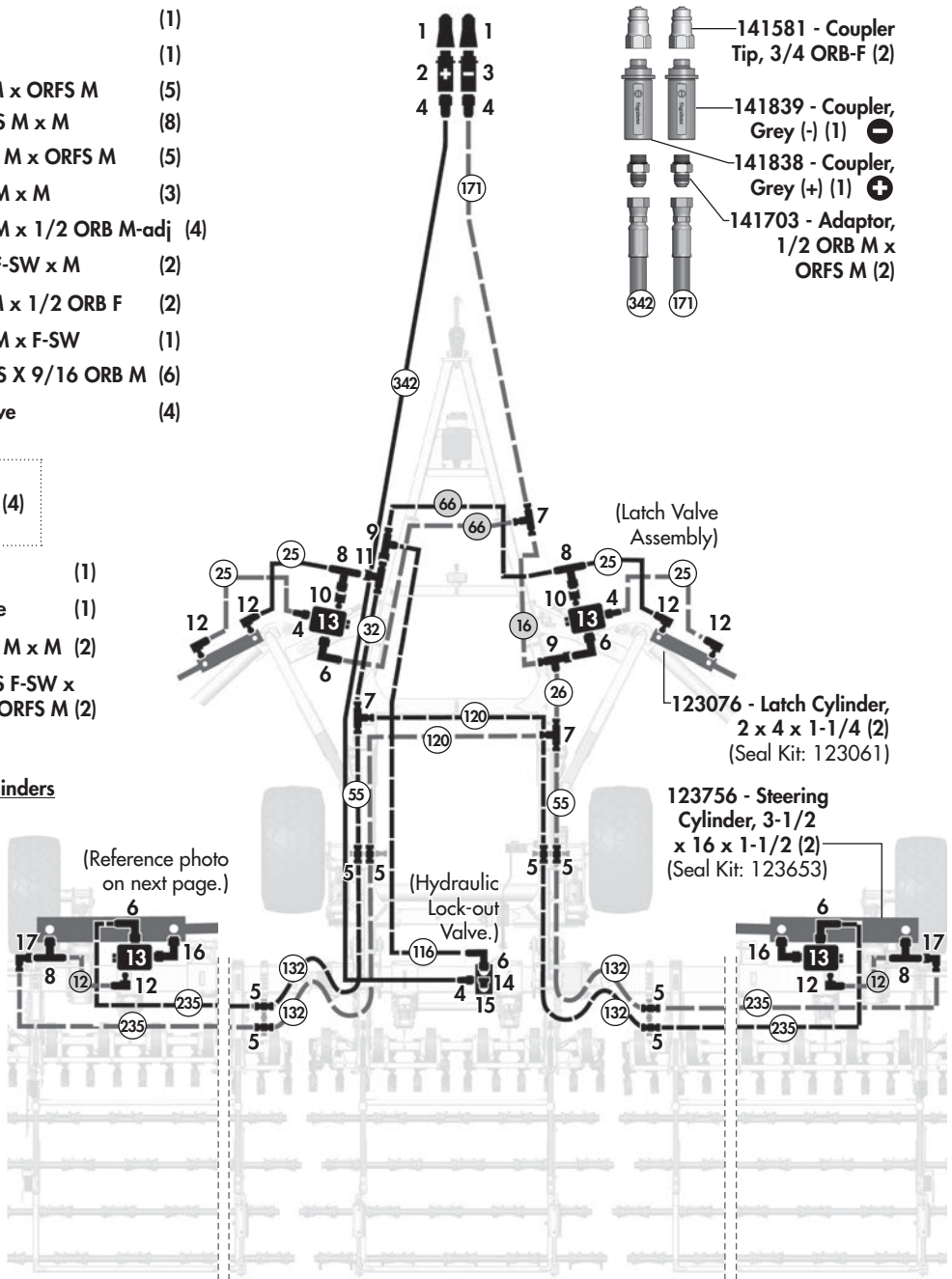

LH Latch Valve Components

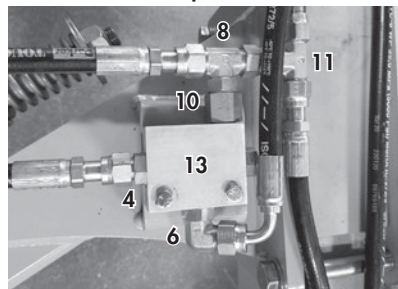

RH Latch Assembly Overview

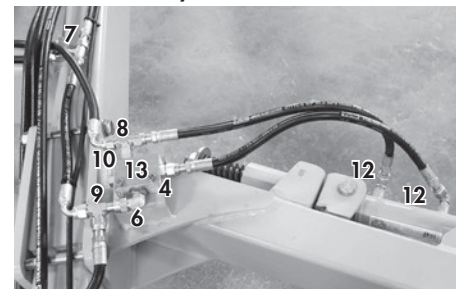

Hydraulic Layout - Latch & Endwheel Steering

LH Endwheel Valve Assembly Overview

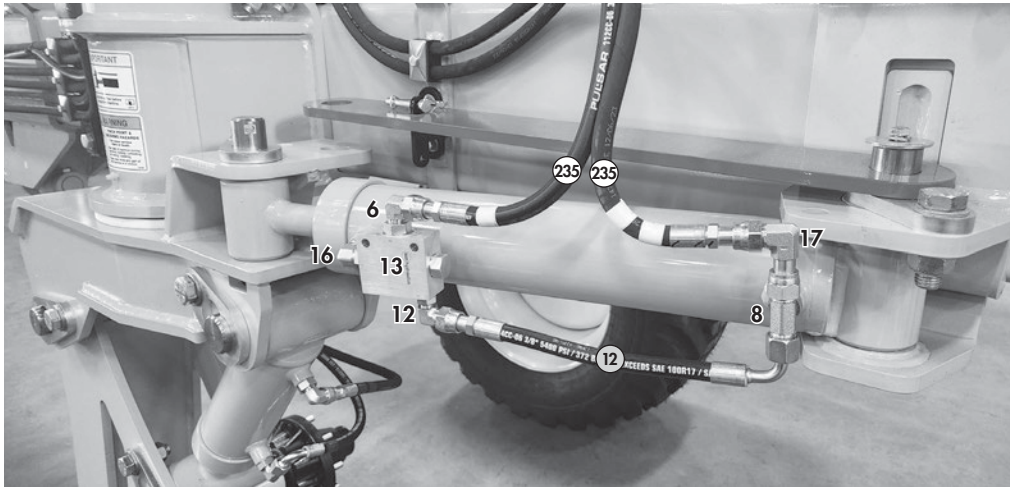

(Hydraulic part reference on previous page.)

Hydraulic Lock-Out Valve Overview

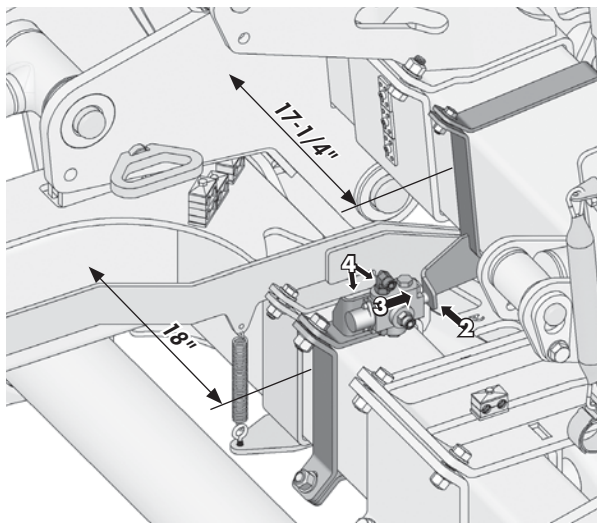

Installation Instructions:

1. With the Strawmaster X in transport position, fully retract the transport cylinders.
2. Move the push arm clamp so that the push arm face is in line with the valve piston.
3. Slide the valve down adjustment slot until the piston is pushed in all the way, then move it back 1/16\".
4. Tighten the valve mounting bolts.

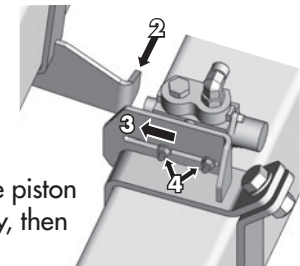

Electrical Layout / Light Components

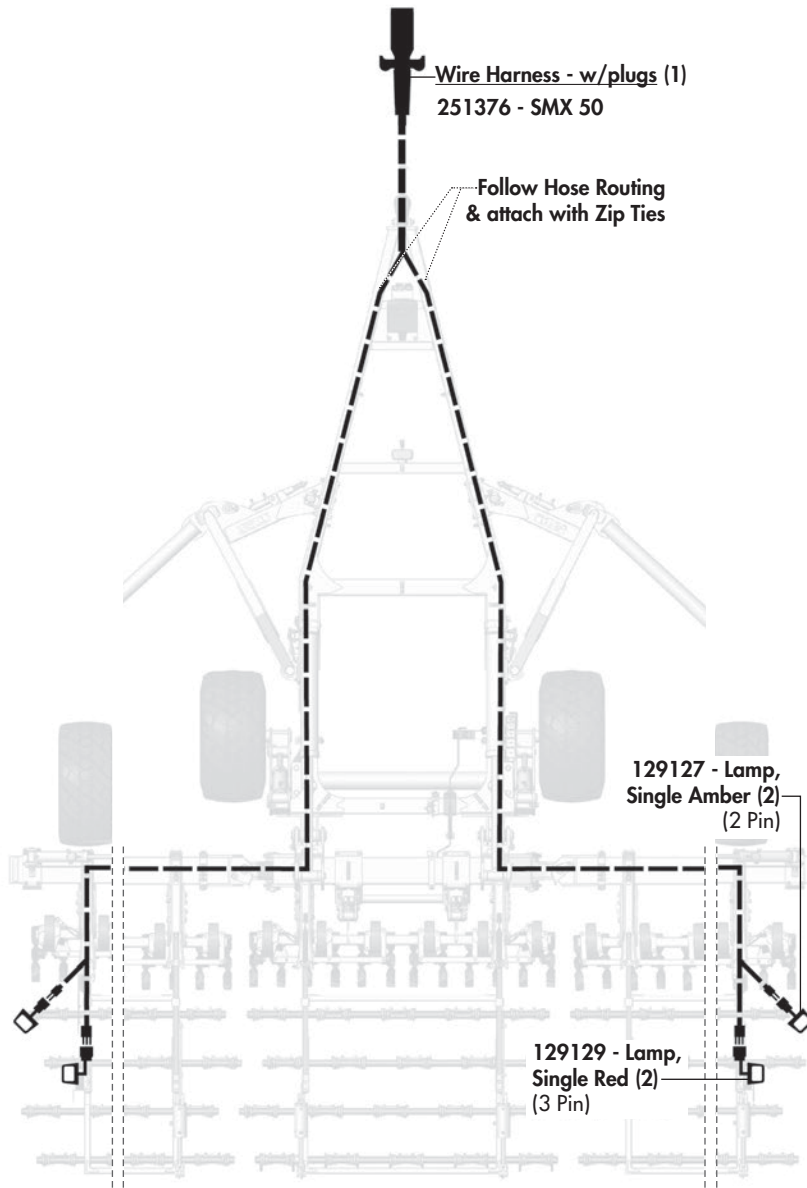

Light Overview (LH Shown)

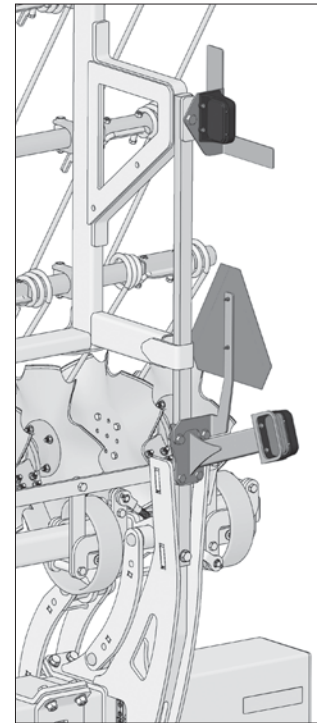

SMV Sign Mount (LH Only)

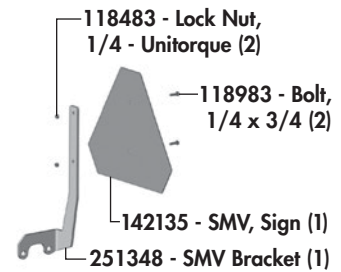

Light Mount - Upper (LH Shown)

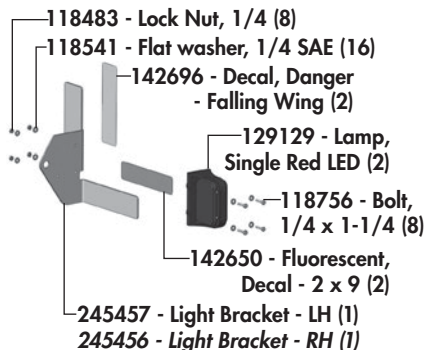

Light Mount - Lower (LH Shown)

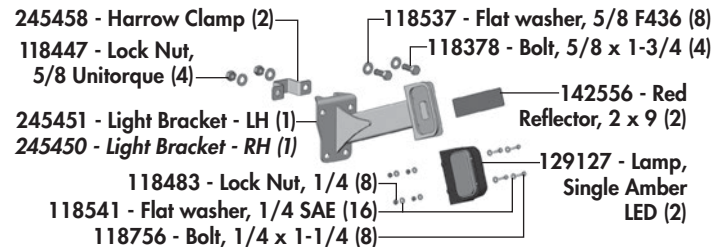

Warranty

2 Year **Limited Warranty - Agricultural Products**

Degelman Industries LP (“Degelman”) warrants to the original purchaser of any new Degelman equipment, purchased from an authorized Degelman dealer, that the equipment will be free from defects in material and workmanship for a period of two (2) years from the date of delivery, for non-commercial use (including farm, institutional, government, and municipality) and (1) year from the date of delivery for commercial use. The obligation of Degelman to the purchaser under this warranty is limited to the repair or replacement of defective parts in the first year and to the provision, but not the installation of replacement parts in the second year. Degelman reserves the right to inspect any equipment or parts which are claimed to have been defective in material or workmanship.

This warranty limits its replacement or repair coverage to what is consistent with the warranty of Degelman’s suppliers of purchased components.

Replacement or repair parts installed in the equipment covered by this limited warranty are warranted for ninety (90) days from the date of delivery of such part or the expiration of the applicable new equipment warranty period, whichever ever occurs later. Warranted parts shall be provided at no cost to the user at an authorized Degelman dealer during regular working hours. Warranted replacement parts will either be replaced or rebuilt at Degelman’s discretion.

Disclaimer of implied warranties & consequential damages

This warranty shall not be interpreted to render Degelman Industries LP liable for injury, death, property damage or damages of any kind, whether direct, consequential, or contingent to property. Without limiting the generality of the foregoing, Degelman shall not be liable for damages resulting from any cause beyond its reasonable control, including, without limitation, loss of crops, any expense or loss of labour, supplies, rental machinery or loss of use.

No other warranty of any kind whatsoever, express or implied is made with respect to this sale; and all implied warranties of merchantability and fitness for a particular purpose which exceed the obligations set forth in this written warranty are hereby disclaimed and excluded from this sale. This exclusion shall not apply in any jurisdiction where it is not permitted by law.

This limited warranty shall not apply:

1. If, in the sole opinion of Degelman, the unit has been subjected to misapplication, abuse, misuse, negligence accident or incorrect off-site machine set-up.
2. To any goods that have sustained damage or deterioration attributable to a lack of routine maintenance (eg. Check and Re-torque of fastening hardware, Hydraulic fluid purities, drive train alignments, and clutch operation)
3. If parts not made or supplied by Degelman have been used in the connection with the unit, if, in the sole judgement of Degelman such use affects its performance, safety, stability or reliability.
4. If the unit has been altered or repaired outside of an authorized Degelman dealership in a manner which, in the sole judgement of Degelman, affects its performance, safety, stability or reliability.
5. To expendable or wear items such as (eg. Harrow tines, Rock Picker and Rock Rake wear teeth and replaceable bushings and pins.) and any other items that in the company’s sole judgement are a wear item.

No employee or representative of Degelman Industries LP is authorized to change this limited warranty in any way or grant any other warranty unless such change is made in writing and signed by the Degelman Service Manager.

This limited warranty is subject to any future availability of supply, which may directly affect Degelman’s ability to obtain materials or manufacture replacement parts.

Degelman reserves the right to make improvements in design or changes in specifications at any time, without incurring obligations to owners of equipment previously delivered.

This limited warranty is subject to compliance by the customer to the enclosed *Retail Customer’s Responsibility Under Degelman Warranty*.

Warranty

Retail Customer's Responsibility Under Degelman Warranty.

It is the retail customer and/or Operator's responsibility to read the Operator's Manual, to operate, lubricate, maintain and store the equipment in accordance with all instructions and safety procedures. Failure of the operator to read the operators manual is a misuse of this equipment.

It is the retail customer and/or operators responsibility to inspect the product and to have any part(s) repaired or replaced when continued operation would cause damage or excessive wear to other parts or cause safety hazard.

It is the retail customer's responsibility to deliver the product to the authorized Degelman dealer, from whom he purchased it, for service or replacement of defective parts, which are covered by warranty. Repairs to be submitted for warranty consideration must be made within forty-five days of failure.

It is the Retail Customer's responsibility for any cost incurred by the dealer for hauling of the product for the purpose of performing a warranty obligation or inspection.

WARRANTY INFORMATION

Make certain the warranty registration card has been forwarded to:

**Degelman Industries LP
Box 830 -272 Industrial Dr.
Regina, SK, Canada
S4P 3B1**

Always give your dealer the serial number of your Degelman product when ordering parts or requesting service or other information.

The serial number is located on the serial number plate (*similar to the one shown in the image below*). In the space provide, please record the model number, the serial number and the date of purchase to assist your dealer in providing you with prompt and efficient service.

SERIAL NUMBER: _____

MODEL NUMBER: _____

DATE OF PURCHASE: _____



