

## *manure spreader*

# M28

# M34

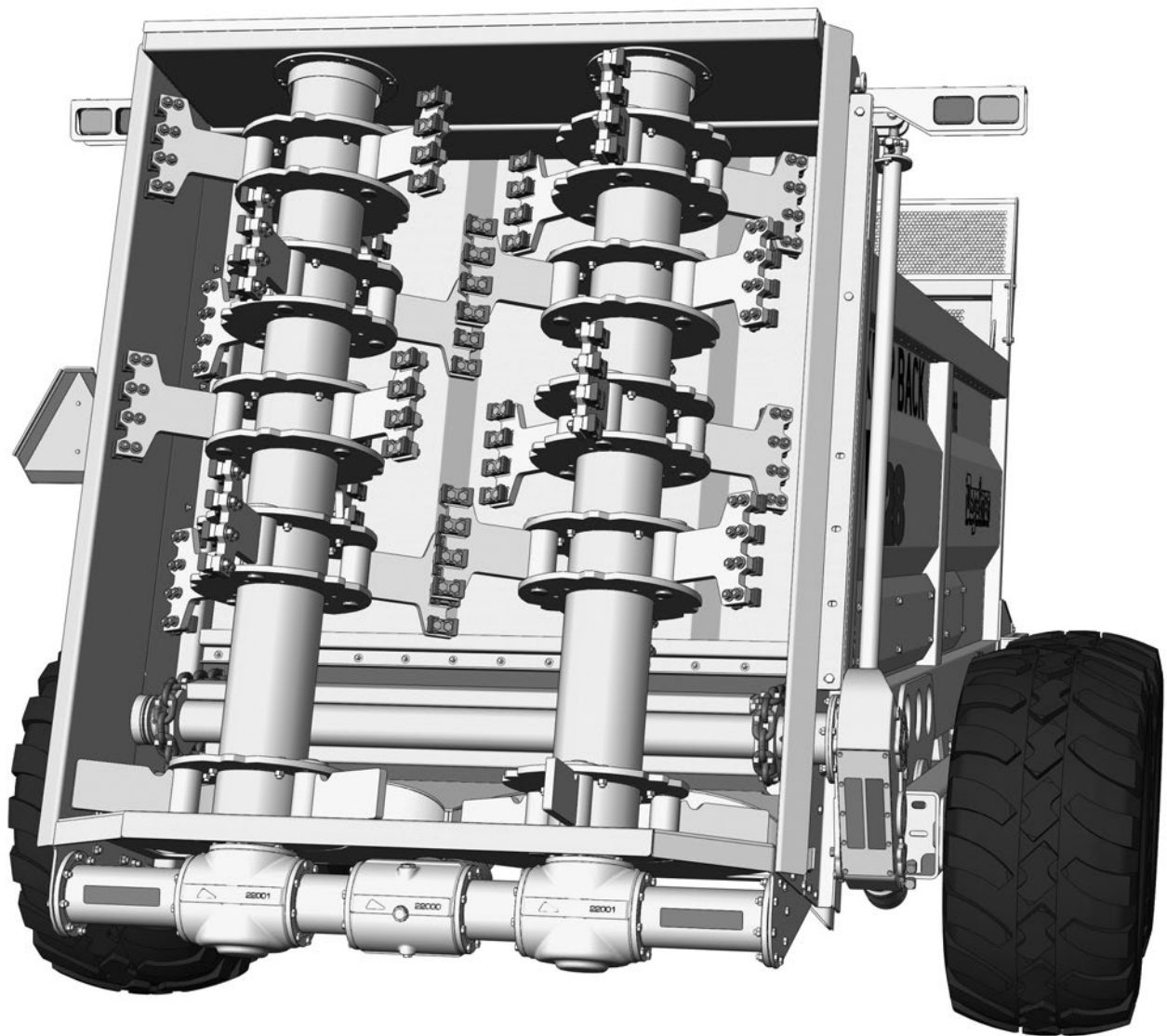

143678 v1.0

**DEGELMAN INDUSTRIES LP**  
BOX 830-272 INDUSTRIAL DRIVE,  
REGINA, SK, CANADA, S4P 3B1  
FAX 306.543.2140 PH 306.543.4447  
1.800.667.3545 DEGELMAN.COM

**MANURE SPREADER**  
**M28 / M34**

SN: 1311 and above



# QUICK-START GUIDE\* for MANURE SPREADER

\* Refer to operators manual for complete safety and operation info.



# Zegelman

## A Hook-up to Manure Spreader

**NOTE:** Stop the tractor engine, place all controls in neutral, set park brake before dismounting.

1. Connect and properly secure to tractor drawbar.
2. Connect PTO driveline to tractor.
3. Connect the Flow Control cable plugs.
4. Connect the Electrical Light plug.
5. Connect the Hydraulics. **① CHAIN CONVEYOR CIRCUIT.....Hydraulic Motor**  
**② GATE LIFT CIRCUIT.....Rear Gate Cylinders**
6. Raise, adjust hitch jack 90° to storage position, or relocate to alternate side storage location.

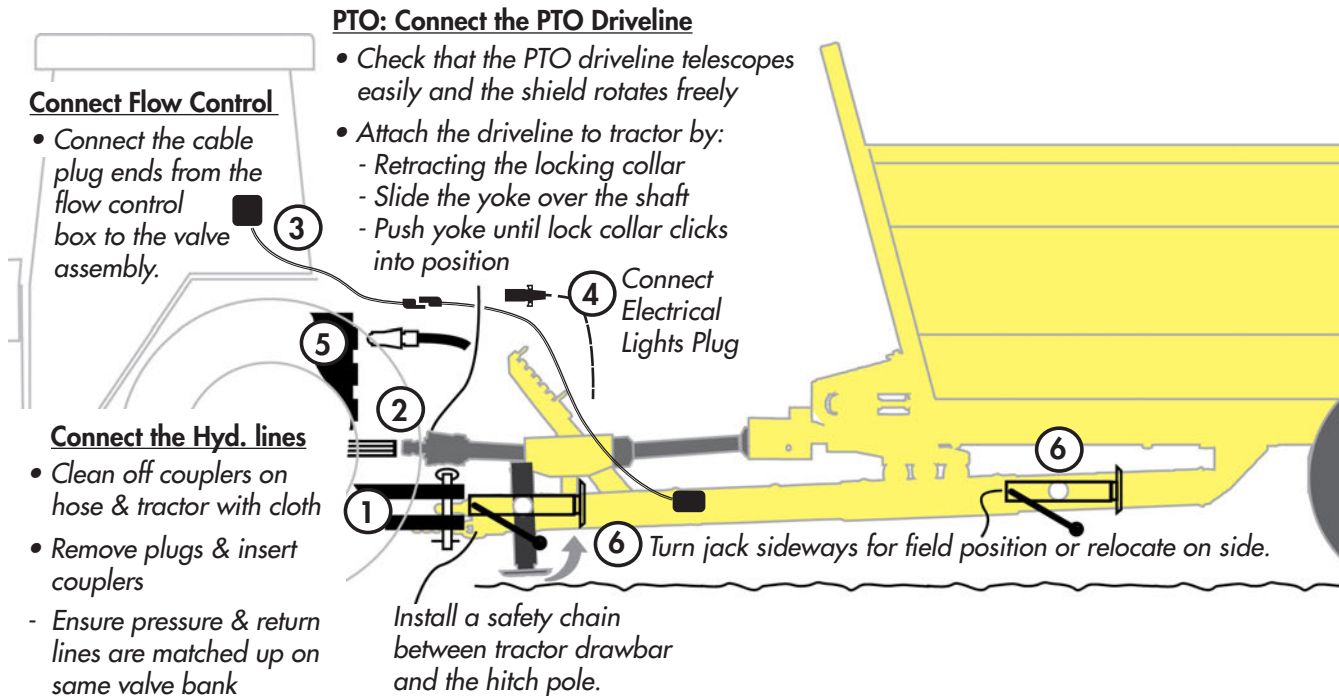

## B Loading the Manure Spreader

1. Fully close the rear hydraulic gate.

**NOTE:** - Always check the floor drag chain and slats to make sure they are not frozen to the bottom of the bed.  
- It is recommended to make sure chains and table floor are operating properly before loading the spreader.

2. Load the Spreader.

**NOTE:** - The moisture content will determine how full it can be loaded. Refer to the specifications for capacity.  
- Do not heap load such that manure is allowed to fall off spreader during transporting on roadways.  
- Solid manure can generally be loaded level to slightly heaped. High moisture materials may limit loading.  
- Use front mesh cover when loading wet, slurry materials. When spreading coarser material, mesh cover may be removed for visibility, if desired.

## C Unloading/Operating the Manure Spreader

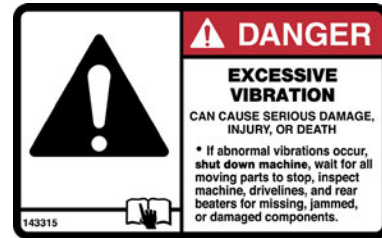

**IMPORTANT:** For customers with John Deere tractors, to reduce the risk of damaging your M28/34 driveline clutches, please contact your local JD Dealer regarding PTO calibration and Soft Start settings on tractor.

1. Start up the rear beaters (PTO) and bring up to speed.
2. Fully open rear gate all the way to the top.
3. Start the table floor: Turn on Control Box. Turn on the hydraulics used to start the table floor moving. Adjust speed with the Flow Control Dial. (A typical starting speed on the flow control dial is 40, based on spreading cattle manure. Operators may wish to slow this down a bit depending on preference or material being spread.)



**NOTE:** - A slower speed results in a finer spread as the beaters have more time to process the material.  
- At the end of the day, turn off the Control Box power switch to prevent possibility of battery drain.

4. Travel Speed: - A suggested starting speed is between 4-5 mph. This can be adjusted to operator preference. The effective spread is roughly 60ft (although thinned out material may cover distances of up to 100ft).
5. IMPORTANT: Lower Gate as Load Decreases

**DANGER:** When the load decreases, it is strongly recommended to lower the rear gate about 1/3 of the way down to prevent debris from being projected towards the front.

(Normally, the load itself blocks possible manure and loose materials from being thrown towards the front. As the load/pile gets reduced, the rear beaters may throw some material forward.)



## D Unplugging the Manure Spreader

1. Stop the table floor: Disengage the hydraulics that run the table floor chains and turn off flow control box.
2. Lower RPM: After PTO clutch dis-engages, lower RPM below 500 RPM in order for it to re-engage.
3. Reverse the Table Floor Direction: Reverse the hydraulics used to start the table floor moving in order to back material away from beaters. Stop table after material is backed away from beaters or if pile doesn't move.
4. Re-start Beaters: Bring beaters back up to regular speed.
5. Start table floor chain: Re-start table floor movement by turning the hydraulics on in the proper direction.

**NOTE:** If this does not solve the situation, a closer inspection and manual unplugging may be required.

**DANGER:** Stop the tractor engine and wait for all moving parts to stop before servicing or unplugging.



**Maintenance**  
(Check Machine Daily)

- Check for missing, worn or damaged parts.
- Drivelines, PTO, working points & pins

- Hydraulic Connections & Hoses
- Tires, Hubs & Spindles

*\* Reference Sheet Quick-Start Guide*

**OPERATORS SECTION - TABLE OF CONTENTS**

<b>Introduction</b>	<b>2</b>
<b>Overview</b>	<b>3</b>
<b>Safety</b>	<b>4</b>
<b>Preparation</b>	
Hook-Up / Unhooking	6
Tractor & Spreader Preparation	7
<b>Operation</b>	
Operation Safety & Preparation	8
Loading / Unloading	9
Freezing Weather Operation	10
Optional - Material Trailer Use	10
<b>Transporting &amp; Storage</b>	<b>11</b>
<b>Service &amp; Maintenance</b>	
Safety & Specifications	12
Service Intervals	15
Adjustments & Repair	16
Troubleshooting	23

**PARTS SECTION - TABLE OF CONTENTS**

<b>Parts Section - Table of Contents</b>	<b>24</b>
<b>Warranty</b>	<b>49</b>



# Introduction

---

## M28 & M34 SERIES MANURE SPREADERS

---



**CONGRATULATIONS** Congratulations on your choice of a Degelman M28/M34 Manure Spreader to complement your farming operation. It has been designed and manufactured to meet the needs of a discerning agricultural market for the efficient and uniform spread distribution of manure. Use this manual as your first source of information about this machine. If you follow the instructions given in this manual, your machine will work well for many years.

Safe, efficient and trouble free operation of your Degelman Spreader requires that you and anyone else who will be operating or maintaining the Spreader, read and understand the Safety, Operation, Maintenance and Troubleshooting information contained within this Manual.

Keep this manual handy for frequent reference and to pass on to new operators or owners. Call your Degelman Dealer if you need assistance, information or additional copies of the manual.

**OPERATOR ORIENTATION** - The directions left, right, front and rear, as mentioned throughout the manual, are as seen from the tractor drivers' seat and facing in the direction of travel.



# Overview

## TO THE NEW OPERATOR OR OWNER

The Degelman M28 & M34 Manure Spreaders are designed to efficiently and uniformly spread manure in widths of up to 60 feet in fields. Many of the features incorporated into this machine are the result of suggestions made by customers like you.

It is the owner's or operator's responsibility to read this manual carefully to learn how to operate the machine safely and how to set it to provide maximum efficiency. Safety is everyone's business. By following safe operating practices, a safe environment is provided for the operator and bystanders.

The manual will take you step-by-step through your working day. By following the operating instructions in conjunction with a good maintenance program, your machine will provide many years of trouble-free service.

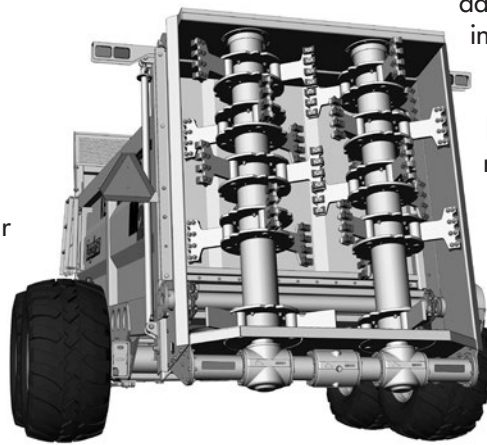

## PRINCIPLES OF OPERATION

The Manure Spreader consists of a smooth walled material trailer with a floor chain drag system that pulls material steadily through a discharge gate at the rear of the machine where the dual vertical beaters process and distribute the material at high speeds in a uniform spread pattern.

The dual rear beaters are directly driven by gearboxes that are connected to the tractor's PTO through drivelines.

The floor chain drag system is hydraulically controlled and incorporates a "Flow Control System" adjusted by an incremental dial located on an in-cab control box. This controls the speed of which the chains drag material towards the rear beaters. The chain is driven by a hydraulic motor and gearbox located on the rear right-hand side of the spreader.

A rear gate is used to prevent material from packing into the rear beaters while loading and to prevent material from falling out during transport. It is raised and lowered by two hydraulic cylinders.

### Spreader Components

1. Hitch Frame
2. Walking Axle
3. Material Trailer
4. Conveyor Chain/ Slat Assembly
5. Rear Gate
6. Beater Assembly
7. Chain Drive/Hyd. Motor/Gearbox
8. PTO Driveline
9. Conveyor Axle
10. Chain Shield
11. Upper Guard
12. Mesh Cover

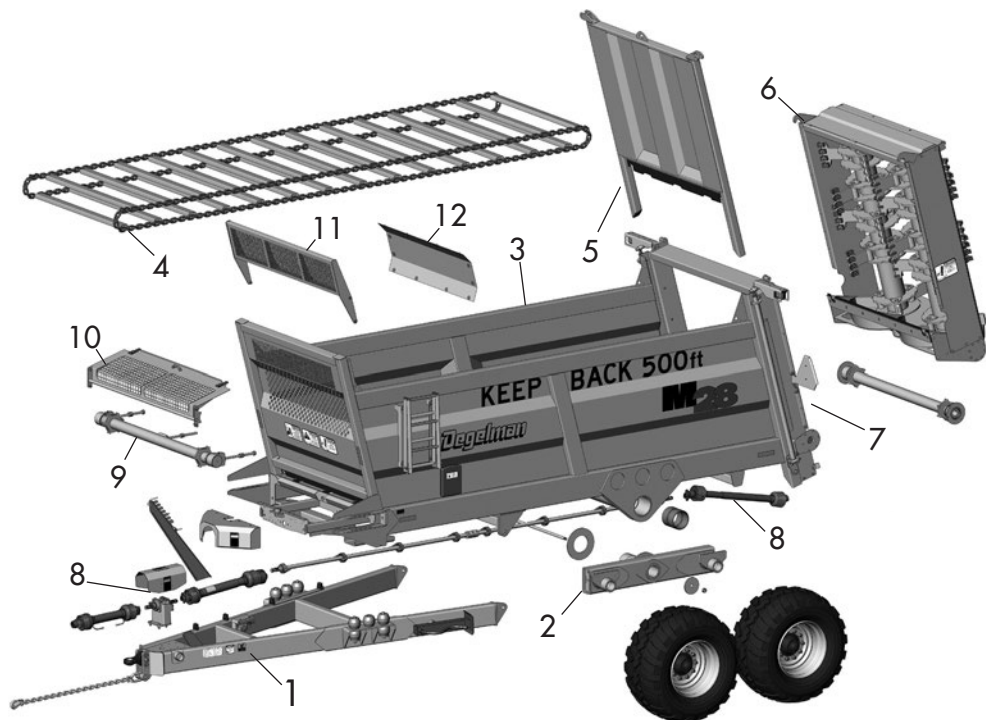

## Why is SAFETY important to YOU?

3 **BIG** Reasons:

- Accidents Can Disable and Kill
- Accidents Are Costly
- Accidents Can Be Avoided



### SAFETY ALERT SYMBOL

---

The **Safety Alert Symbol** identifies important safety messages applied to the Manure Spreader and in this manual. When you see this symbol, be alert to the possibility of **injury or death**. Follow the instructions provided on the safety messages.

The **Safety Alert Symbol** means:

**ATTENTION!**  
**BECOME ALERT!**  
**YOUR SAFETY IS INVOLVED!**

### SIGNAL WORDS

---

Note the use of the Signal Words: **DANGER**, **WARNING**, and **CAUTION** with the safety messages. The appropriate Signal Word has been selected using the following guidelines:



**DANGER:** Indicates an imminently hazardous situation that, if not avoided, **WILL** result in death or serious injury if proper precautions are not taken.



**WARNING:** Indicates a potentially hazardous situation that, if not avoided, **COULD** result in death or serious injury if proper precautions are not taken.



**CAUTION:** Indicates a potentially hazardous situation that, if not avoided, **MAY** result in minor or moderate injury if proper practices are not taken, or, serves as a reminder to follow appropriate safety practices.



# Safety





## SAFETY

**YOU** are responsible for the safe operation and maintenance of your Degelman Manure Spreader. **YOU** must ensure that you and anyone else who is going to operate, maintain or work around the Spreader be familiar with the operating and maintenance procedures and related **SAFETY** information contained in this manual. This manual will take you step-by-step through your working day and alerts you to all good safety practices that should be adhered to while operating this equipment.

Remember, **YOU** are the key to safety. Good safety practices not only protect you but also the people around you. Make these practices a working part of your safety program. Be certain that **EVERYONE** operating this equipment is familiar with the recommended operating and maintenance procedures and follows all the safety precautions. Most accidents can be prevented. Do not risk injury or death by ignoring good safety practices.

- Manure Spreader owners must give operating instructions to operators or employees before allowing them to operate the Spreader, and at least annually thereafter.
- The most important safety device on this equipment is a SAFE operator. It is the operator's responsibility to read and understand ALL Safety and Operating instructions in the manual and to follow these. All accidents can be avoided.
- A person who has not read and understood all operating and safety instructions is not qualified to operate the machine. An untrained operator exposes himself and bystanders to possible serious injury or death.
- Do not modify the equipment in any way. Unauthorized modification may impair the function and/or safety and could affect the life of the equipment.
- Think SAFETY! Work SAFELY!

## GENERAL SAFETY

1. Read and understand the Operator's Manual and all safety signs before operating, maintaining or adjusting the Manure Spreader. 
2. Install and properly secure all shields and guards before operating. Use hitch pin with a mechanical locking device.
3. Have a first-aid kit available for use should the need arise and know how to use it. 
4. Have a fire extinguisher available for use should the need arise and know how to use it. 
5. Wear appropriate protective gear. This list includes but is not limited to:
  - A hard hat
  - Protective shoes with slip resistant soles
  - Protective glasses or goggles 
  - Heavy gloves 
  - Wet weather gear
  - Hearing protection
  - Respirator or filter mask
6. Clear the area of people, especially small children, and remove foreign objects from the machine before starting and operating.
7. Do not allow riders.
8. Stop tractor engine, set park brake, remove ignition key and wait for all moving parts to stop before servicing, adjusting, repairing or unplugging.
9. Review safety related items with all operators annually.

# Preparation

## HOOK-UP / UNHOOKING

The Manure Spreader should always be parked on a level, dry area that is free of debris and foreign objects. Follow this procedure when attaching:

1. Clear the area of bystanders and remove foreign objects from the machine and working area.
2. Make sure there is enough room to back the tractor up to the hitch pole.
3. Start the tractor and slowly back it up to the hitch point.
4. Stop the tractor engine, place all controls in neutral, set park brake and remove ignition key before dismounting.
5. Use the hitch pole jack to raise or lower the pole to align with the drawbar.
6. Install a drawbar pin with provisions for a mechanical retainer such as a Klik pin. Install the retainer.
7. Install a safety chain between the tractor drawbar and the hitch pole.
8. Connect PTO driveline to tractor.
9. Connect the Flow Control cable plugs.

10. Connect the Electrical Light plug.

11. Connect the hydraulics. To connect, proceed as follows:

- Use a clean cloth or paper towel to clean the couplers on the ends of the hoses. Also clean the area around the couplers on the tractor.
- Remove the plastic plugs from the couplers and insert the male ends.

**NOTE:** If the direction of motion is wrong, reverse the couplers.

12. Raise the hitch jack and rotate it 90° to place in its stowed position or relocate on jack bushing located on the side frame (see detail below).

13. When unhooking from the tractor, reverse the above procedure.

**NOTE:** Occasionally air may become trapped in the hydraulic circuit, making it necessary to "bleed" the circuit.

To perform this operation cycle the hydraulics several times or especially on older tractors, temporarily loosen an easily accessible hose fitting enough to allow any trapped air to escape while cycling the hydraulics. Retighten fitting.

### PTO: Connect the PTO Driveline

- Check that the PTO driveline telescopes easily and the shield rotates freely.
- Attach the driveline to tractor by:
  - Retracting the locking collar.
  - Slide the yoke over the shaft.
  - Push yoke until lock collar clicks into position.

### Connect Flow Control

- Connect the cable plug ends from the flow control box to the valve assembly.

### Connect the Hyd. lines

- Clean off couplers on hose & tractor with cloth.
- Remove plugs & insert couplers.
- Ensure pressure & return lines are matched up on same valve bank.

Connect Electrical Lights Plug.

Turn jack sideways for field position or relocate on side.

Install a safety chain between tractor drawbar and the hitch pole.

- Always park on a level surface clear of debris and obstacles.

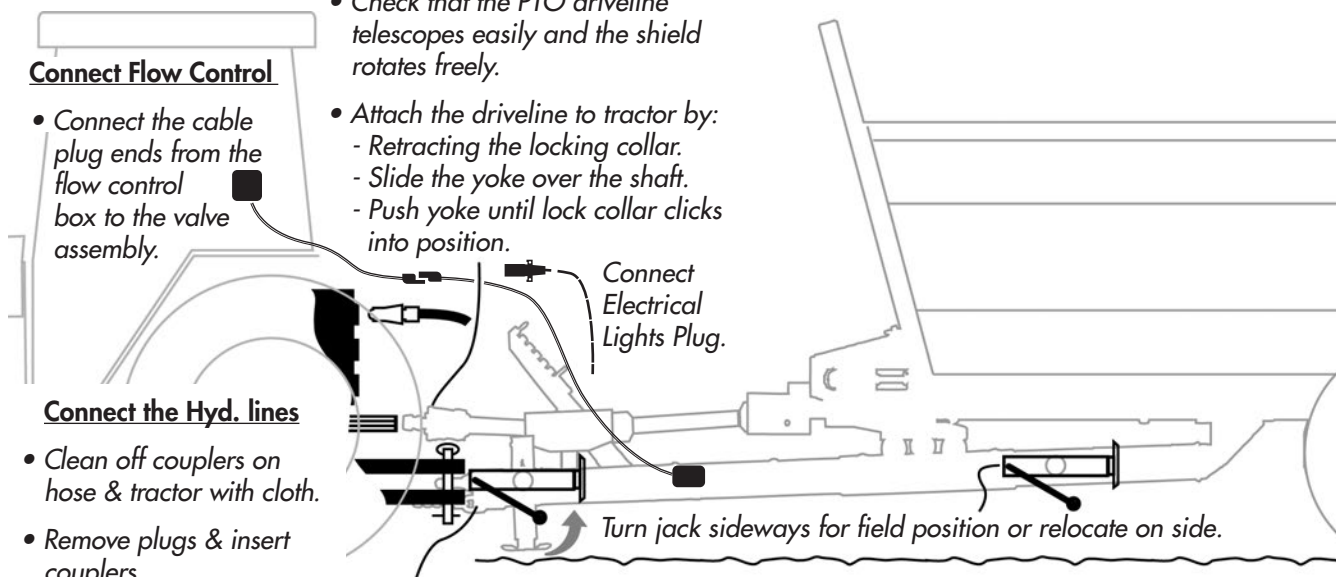

# Preparation

## TRACTOR PREPARATION

Follow this procedure when selecting and preparing a tractor for use with the machine:

1. Use only a tractor of sufficient power and weight to adequately handle the machine. It is recommended that the tractor have at least **180 PTO** horsepower for normal operating conditions.
2. It is recommended to pin the drawbar in its centre draft position.
3. Use only a drawbar pin with provisions for a mechanical retainer such as a Klik pin. Always install the retainer.
4. Always attach a safety chain between the tractor and the machine to prevent unexpected separation.

**⚠ IMPORTANT:** Do not use on a tractor equipped with a PTO shaft adapter to prevent mismatching of PTO speeds and over telescoping of driveline.

5. The drawbar pin to 1000 PTO shaft end dimension should be either:  
**16 inches** for **1-3/8"**, 21 spline PTO models  
**20 inches** for **1-3/4"**, 20 spline PTO models

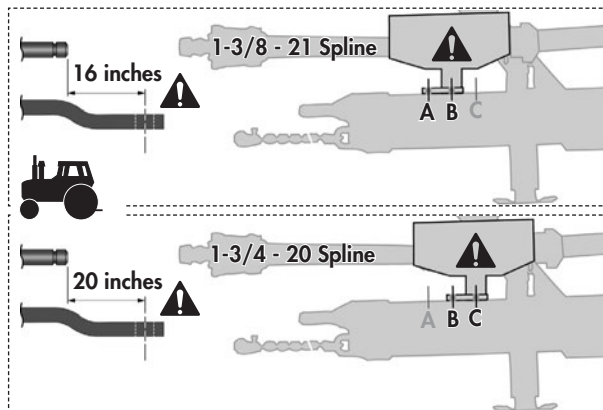

6. The front PTO bearing holder position should be either:

**A-B** Forward for 1-3/8", 21 spline PTO models.

**B-C** Rear for 1-3/4", 20 spline PTO models.

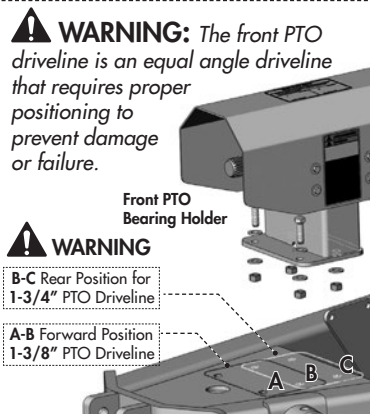

## SPREADER PREPARATION

Although there are no operational restrictions on the Manure Spreader when it is new, there are some mechanical checks that must be done to ensure the long term integrity of the unit. When using the machine for the first time, follow this procedure:

**⚠ IMPORTANT:** It is extremely important to follow all of the procedures especially those listed in the "Before using" section below to avoid damage:

### A. Before using:

1. Read Safety Info. & Operator's Manual. Do not operate the spreader until the safety precautions in this manual and the decals on the spreader have been read and understood by the operator.
2. Check for proper assembly and adjustment and make sure all bolts are tight. All bolts were checked at the factory when assembled but need to be checked again as vibrations in shipment may loosen them slightly.

**Recommended Wheel Bolt Torque Specs:**  
**505 ft-lbs (683 N-m) - dry**  
**Note:** Re-check torque on wheel bolts after a couple of hours, and the following day.

3. Complete steps in "Pre-Operation Checklist".
4. Lubricate the machine completely. Refer to the Lubrication section of this manual (p.14). The initial grease was applied at the factory but proper maintenance is the user's responsibility and must begin before the first use.  
**NOTE:** Ensure drivelines are properly lubricated.
5. Confirm Front PTO driveline/tractor hitch distance settings. (refer to "Tractor Preparation" steps 5 & 6)
6. Operate the machine slowly for a period of time to run the chains in and confirm that all parts work freely.

### B. After operating for 2 hours:

1. Re-torque wheel bolts.
2. Check torque on the driveline cut-out clutch bolt (taper pin). Tighten to **75 ft-lbf (102 N-m)**
3. Check all hardware. Tighten as required.
4. Check all hydraulic system connections. Tighten if any are leaking.
5. Tighten chain.

### C. After operating for 8 hours:

1. Repeat Step B.
2. Go to the service schedule as outlined in the "Service & Maintenance" section.

# Operation

## OPERATING SAFETY

1. Read and understand the Operator's Manual and all safety signs before using.
2. Stop tractor engine, place all controls in neutral, set park brake, remove ignition key and wait for all moving parts to stop before servicing, adjusting, repairing or unplugging.
3. Keep hands, feet, hair and clothing away from all moving and/or rotating parts.



4. Do not allow riders on the Manure Spreader or tractor during operation or transporting.
5. Keep all shields and guards in place when operating.
6. Clear the area of all bystanders, especially children, before starting.
7. Be careful when working around or maintaining a high-pressure hydraulic system. Ensure all components are tight and in good repair before starting.
8. Clean all reflectors, lights and the SMV sign (if applicable) before transporting on a highway or public road. Be sure to check with local highway authorities and comply with their lighting requirements.
9. Stay well back from machine when operating to prevent being hit by flying rocks and debris. Keep others a minimum of **500 ft (150m) away**.

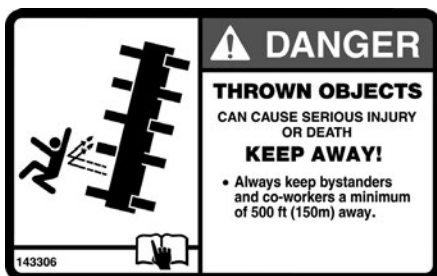



## PRE-OPERATION CHECKLIST

It is important for both personal safety and maintaining the good mechanical condition of the machine that this pre-operational checklist be followed.

**Before operating the machine and each time thereafter, the following areas should be checked off:** 

- 1. Lubricate the machine completely. Refer to the schedule outlined in the "Service & Maintenance Section" of this manual.
- 2. Use only a tractor of adequate power (**180 hp minimum**) and weight to handle the spreader.
- 3. Ensure that the machine is properly attached to the tractor using a drawbar pin with provisions for a mechanical retainer. Make sure that a retainer such as a Klik pin is installed.
- 4. Ensure the safety chain on the hitch is installed.
- 5. Check tires and ensure that they are inflated to the specified pressure: **65 psi (450 kPa)** or **58 psi (400 kPa)** for large tire option.
- 6. Check oil level in the tractor hydraulic reservoir. Top up as required.

 **WARNING:** Use extreme care when working around a high pressure hydraulic system. Make sure all connections are tight and all components are in good repair. Wear hand and eye protection when searching for suspected leaks. 

- 7. Inspect all hydraulic lines, hoses, fittings and couplers for tightness. Tighten if there are leaks. Use a clean cloth to wipe any accumulated dirt from the couplers before connecting to the tractor's hydraulic system.
- 8. Inspect all moving and rotating parts. Remove any debris that has become entangled in them.
- 9. Make sure that all guards and shields are installed and secured in position.
- 10. Check the oil level in the gearboxes. Top up as required.
- 11. Insure that the PTO driveline is securely attached on both ends and can telescope easily. Check that the PTO driveline shield rotates freely.

# Operation

## LOADING

**⚠ IMPORTANT:** When parking the spreader for loading, put the tractor in **PARK** or **NEUTRAL** and **apply the parking brake**.

### 1. Fully Close Rear Hydraulic Gate

**NOTES:** - It is unlawful to allow any manure spillage to occur on public roadways. Do not heap load such that manure is allowed to fall off spreader during transporting on roadways.

- Always check the floor drag chain and slats to make sure they are not frozen to the bottom of the bed. Operating the spreader when the slats or chain are frozen to the bed may cause damage. Also make sure there are no lumps of manure frozen to the floor.

- Make sure chains and table floor are operating properly before loading the spreader.

**2. Load the Spreader** - The moisture content will determine how full it can be loaded. Refer to the specifications for capacity. Solid manure can generally be loaded level to slightly heaped. High moisture materials are heavier and may limit loading.

- Use front mesh cover when loading wet, slurry materials. Remove mesh cover for visibility, if desired, when spreading for coarser material.

## UNLOADING

**⚠ IMPORTANT:** Ensure all items under Operating Safety are followed and ensure all bystanders are a minimum of **500 ft (150m) away before operating!**

**⚠ IMPORTANT:** For customers with John Deere tractors, to reduce the risk of damaging your M28/34 driveline clutches, please contact your local JD Dealer regarding PTO calibration and Soft Start settings on tractor.

**1. Start up the Rear Beaters** - Start the PTO and get the beaters running up to speed.

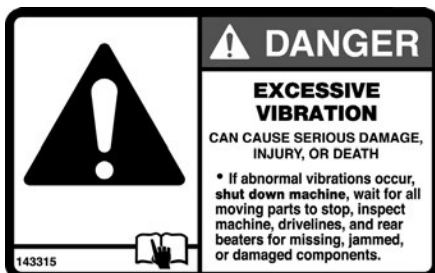

**⚠ DANGER:** If, at any time, abnormal vibrations occur, **shut down machine**, wait for all moving parts to stop, inspect machine, drivelines, and rear beaters for missing, jammed, or damaged components.

## UNLOADING CONTINUED...

**2. Fully Open Rear Gate** - Fully extend the cylinders so the gate is fully open all the way to the top.

**NOTE:** Before starting the table floor, the operator should get the beaters up to speed and fully open the rear gate. This prevents the spreader from overworking itself from material being pulled up against the rear gate.

### 3. Start the Table Floor

Turn on power switch on the Control box.

Turn on the hydraulics used to start the table floor moving. This speed is adjusted with the "Flow Control Dial".



The flow control dial adjusts the "table speed" at which material is being pulled towards the rear beaters. The slower the speed - the finer the spread as the rear beaters have more time to "process" the material. The typical starting speed on the flow control dial is **40** (based on spreading cattle manure). Operators may wish to slow this down a depending on preference or material being spread.

**Note:** At the end of the day it is recommended to turn off the power switch on the "Flow Control Box" to prevent possibility of battery drain.

**4. Travel Speed** - A suggested starting speed is between **4-5 mph**. This can be adjusted to operator preference.

The effective spread is roughly **60ft** (although thinned out material may cover distances of up to 100ft).

### 5. Lower Gate as Load Decreases



**⚠ DANGER:** Normally, the load itself blocks manure and loose materials from being thrown towards the front. As the load/pile gets reduced, the rotation of the rear beaters can throw some material forward, therefore it is strongly recommended to lower the rear gate about 1/3 of the way down to prevent debris from being projected towards the front.

# Operation

**⚠ WARNING:** Stop tractor engine, place all controls in neutral, set park brake, remove ignition key and wait for all moving parts to stop before servicing, cleaning, adjusting, repairing or unplugging.

## UNPLUGGING

The following is a recommended procedure that may help if the manure spreader becomes plugged or the PTO disengages:

### 1. Stop the Table Floor

Disengage the hydraulics on that run the table floor chains and turn off the flow control box.

### 2. Lower RPM

After the PTO clutch dis-engages, the RPM has to be lowered below 500 RPM in order for it to re-engage.

### 3. Reverse the Table Floor Direction

Reverse the hydraulics used to start the table floor moving in order to back material away from beaters. Stop table after material is backed away from beaters or if pile doesn't move.

### 4. Re-start Beaters

Bring beaters back up to regular speed.

### 5. Start Table Floor Chain

Re-start the table floor moving again by turning the hydraulics on in the proper direction.

If this above procedure does not solve the situation, closer inspection and possible manual unplugging may be required. Make sure to stop tractor and wait for all moving parts to stop before servicing or unplugging.

## FREEZING WEATHER OPERATION

- Before loading in freezing weather, make sure the apron chains and slats are not frozen to the floor, the spreader beaters are free to rotate and the rear gate moves freely up and down.
- At end of use, completely empty the last of the spreader contents. Clean any remaining debris from the spreader, the main drive, and the rear gate.
- Ensuring area is clear, slowly engage the PTO & run the spreader for a few minutes to clean out manure debris and to allow any remaining manure and the spreader to freeze dry.
- Run rear gate up and down to clean the gate slides. Park spreader with the gate halfway open.

## OPTIONAL MATERIAL TRAILER USAGE

This manure spreader may also be used as a material trailer by removing the rear beater/frame assembly.

**⚠ WARNING:** Stop tractor engine, place all controls in neutral, set park brake, remove ignition key and wait for all moving parts to stop before servicing, adjusting, repairing or unplugging.

### 1. Disconnect/Remove rear Driveline

Before removing the rear frame assembly, the rear driveline must be disconnected and removed. Store in a safe location.

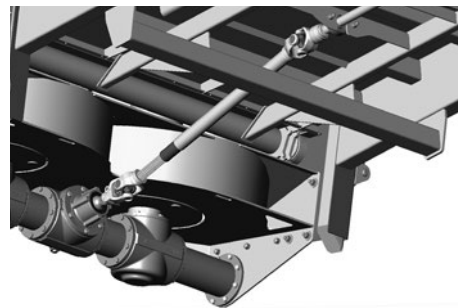

### 2. Disconnect (5) bolts on both sides (10 total).

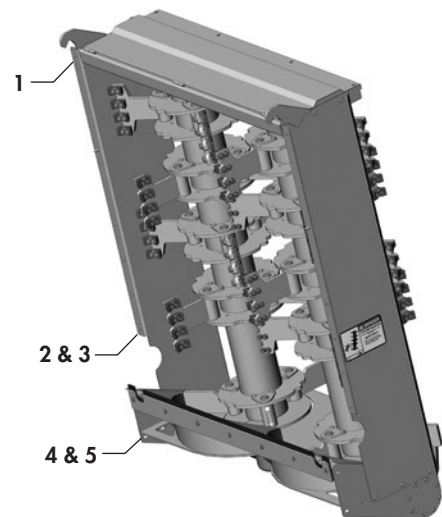

### 3. Securely wrap a chain around rear beaters (above center of gravity).

### 4. With the aid of a front end loader, the "Rear Frame Assembly" will then lift off. Store in a suitable, safe location.

### 5. The unit should now be ready to use as a material trailer/wagon.

# Transporting & Storage

## ⚠ TRANSPORT SAFETY

- Read and understand ALL the information in the Operator's Manual regarding procedures and SAFETY when operating the spreader in the field/yard or on the road.
- Check with local authorities regarding machine transport on public roads. Obey all applicable laws and regulations.
- Always travel at a safe speed. Use caution when making corners or meeting traffic.
- Make sure the SMV (Slow Moving Vehicle) emblem and all the lights and reflectors that are required by the local highway and transport authorities are in place, are clean and can be seen clearly by all overtaking and oncoming traffic.
- Clean off machine to ensure loose debris/materials do not fall from spreader while in transport.
- Keep to the right and yield the right-of-way to allow faster traffic to pass. Drive on the road shoulder, if permitted by law.
- Always use hazard warning flashers on tractor when transporting unless prohibited by law.
- Always use a pin with provisions for a mechanical retainer and a safety chain when attaching to a tractor or towing vehicle.



## TRANSPORT HEIGHT

**⚠ WARNING:** Always check local transport height restrictions and confirm clearances before transporting.

We recommend lowering and securing the front guard assembly before transport:

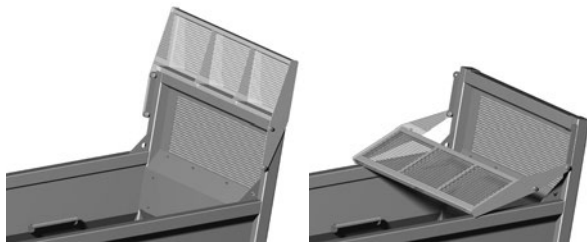

1. Remove top hardware (both sides). Swing down front guard and re-attach hardware.
2. Secure front guard as required.
3. **IMPORTANT:** Properly re-install front guard before use.

## ⚠ STORAGE SAFETY

- Store unit in an area away from human activity.
- Do not permit children to play around the stored unit.

## STORAGE

After the season's use, completely inspect all major systems of the machine. Repair or replace any worn or damaged components to prevent unnecessary down time at the beginning of next season.

Since the unit can be used in extremely adverse conditions during the season, the machine should be carefully prepared for storage to ensure that all dirt, mud, debris and moisture has been removed.

Follow this procedure when preparing to store:

1. Wash the entire machine thoroughly using a water hose or pressure washer to remove all dirt, mud, debris or residue. Manure is acidic and will damage paint and cause rusting of metal components.
2. Inspect all moving or rotating parts to see if anything has become entangled in them. Remove the entangled material.
3. Lubricate all grease fittings to remove any moisture in the bearings.
4. Run the machine slowly for 1 minute to distribute lubricant to all surfaces.
5. Inspect all hydraulic hoses, fittings, lines, couplers and valves. Tighten any loose fittings. Replace any hose that is badly cut, nicked or abraded or is separating from the crimped end of the fitting.
6. Touch up all paint nicks and scratches to prevent rusting.
7. Oil the exposed rams on the hydraulic cylinders to prevent rusting.
8. Select an area that is dry, level and free of debris.

# Service & Maintenance

## HARDWARE SPECIFICATIONS

**Note:** Unless stated otherwise, hardware is typically:  
Hex, Plated GR5 UNC or P8.8 (metric)

## TORQUE SPECIFICATIONS

### Checking Bolt Torque

The tables below give correct torque values for various bolts and capscrews. Tighten all bolts to the torques specified in chart unless otherwise noted. Check the tightness of bolts periodically, using these bolt torque charts as a guide. Replace hardware with the same strength (Grade/Class) bolt.

### IMPERIAL TORQUE SPECIFICATIONS

(Coarse Thread - based on "Zinc Plated" values)

Size	Grade 5	Grade 8
	lb.ft (N.m)	lb.ft (N.m)
1/4"	7 (10)	10 (14)
5/16"	15 (20)	20 (28)
3/8"	25 (35)	35 (50)
7/16"	40 (55)	60 (80)
1/2"	65 (90)	90 (120)
9/16"	90 (125)	130 (175)
5/8"	130 (175)	180 (245)
3/4"	230 (310)	320 (435)
7/8"	365 (495)	515 (700)
1"	550 (745)	770 (1050)
1-1/8"	675 (915)	1095 (1485)
1-1/4"	950 (1290)	1545 (2095)
1-3/8"	1250 (1695)	2025 (2745)
1-1/2"	1650 (2245)	2690 (3645)

### METRIC TORQUE SPECIFICATIONS

(Coarse Thread - based on "Zinc Plated" values)

Size	Class 8.8	Class 10.9
	lb.ft (N.m)	lb.ft (N.m)
M6	7 (10)	10 (14)
M8	16 (22)	23 (31)
M10	30 (42)	45 (60)
M12	55 (75)	80 (108)
M14	90 (120)	125 (170)
M16	135 (185)	195 (265)
M18	190 (255)	270 (365)
M20	265 (360)	380 (515)
M22	365 (495)	520 (705)
M24	460 (625)	660 (895)
M27	675 (915)	970 (1315)
M30	915 (1240)	1310 (1780)
M33	1250 (1695)	1785 (2420)
M36	1600 (2175)	2290 (3110)

## HYDRAULIC SAFETY

- Make sure that all components in the hydraulic system are kept in good condition and are clean.
- Replace any worn, cut, abraded, flattened or crimped hoses and metal lines.
- Do not attempt any makeshift repairs to the hydraulic lines, fittings or hoses by using tape, clamps or cements. The hydraulic system operates under extremely high-pressure. Such repairs will fail suddenly and create a hazardous and unsafe condition.
- Wear proper hand and eye protection when searching for a high-pressure hydraulic leak. Use a piece of wood or cardboard as a backstop instead of hands to isolate and identify a leak. 
- If injured by a concentrated high-pressure stream of hydraulic fluid, seek medical attention immediately. Serious infection or toxic reaction can develop from hydraulic fluid piercing the skin surface.
- Before applying pressure to the system, make sure all components are tight and that lines, hoses and couplings are not damaged.

## HYDRAULIC HOSE SPECIFICATIONS

**Note:** Unless otherwise stated, Hydraulic Hoses are either 3/8 or 1/2 with 3/4 JIC female swivel ends.

## HYDRAULIC HOSE INSTALLATION TIPS

The following tips are to help you identify some possible problem areas in the installation of hydraulic hoses.

1. Installation should be completed in a clean environment clear of dust and contaminants. Hoses and fittings should be capped if not installed.
2. Ensure hoses are not twisted during installation as this may weaken the hose. Also, the pressure in a twisted hose may loosen fittings or connections.
3. Allow sufficient bend radius in hoses when installing to prevent lines from collapsing and flow becoming restricted.
4. When installing hoses in an area of movement or flexing, allow enough free length for motion and to ensure fitting connections are not stressed.
5. Ensure hoses are properly clamped and secured in position after routing is complete to provide a cleaner installation and prevent possible damage or hazards.



# Service & Maintenance

## HYDRAULIC FITTING INSTALLATION



The following info is to help you identify and properly install some of our standard hydraulic fittings.

### SAE (JIC) 37° Flare

JIC fittings - Metal-to-metal sealing type fittings featuring a 37° flare (angle of sealing surface) and straight UNF (Unified National Fine) Threads.

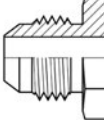
(Lubricated Values)	Dash	Thread Size	Torque - lb.ft (N.m)
	-4	7/16 - 20	9-12 (12-16)
	-6	9/16 - 18	14-20 (19-27)
	-8	3/4 - 16	27-39 (37-53)
	-10	7/8 - 14	36-63 (50-85)
	-12	1-1/16 - 12	65-88 (90-119)

### Tightening JIC 37° Flare Type Fittings

1. Check flare and flare seat for defects that might cause leakage.
2. Align fittings before tightening. Lubricate connections & hand tighten swivel nut until snug.
3. Using two wrenches, torque to values shown in table.

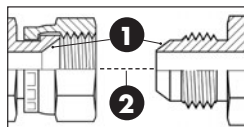

#### Alternate Installation Method

3. Using two wrenches. Place one wrench on the fixed connector body at a clock position of 6 o'clock.
4. Place the second wrench on the second connection as close to the 3 o'clock position as possible.
5. Tighten by rotating the second connection firmly to at least the 4 o'clock position, but no more than the 7 o'clock position. Typically, the larger the fitting size the less rotation required.

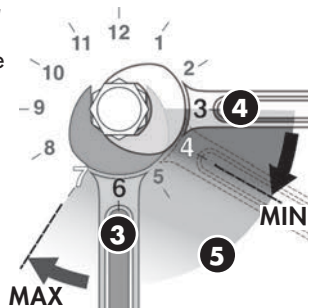

### ORFS (O-Ring Face Seal)

ORFS fittings use an O-ring compression method to seal. This method offers a high level of sealing along with good vibration resistance. Male fittings include an O-ring located in a groove on the flat face. Female fittings feature a flat face and UNF straight threaded swivel nut.

The **Torque** method is recommended for ORFS installation.

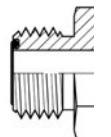
	Dash	Thread Size	Torque - lb.ft (N.m)
	-4	9/16 - 18	18 (25)
	-6	11/16 - 16	30 (40)
	-8	13/16 - 16	40 (55)
	-10	1 - 14	60 (80)
	-12	1-3/16 - 12	85 (115)

### Tightening ORFS (O-Ring Face Seal) Fittings

1. Inspect components and ensure the O-Ring seal is undamaged and properly installed in the groove of the face seal. Replacing the O-Ring may be necessary.
2. Align, thread into place and hand tighten.
3. Tighten to proper torque from the table shown above.

**Note:** A **DASH** size refers to a diameter of a hose (*inside*) or of a tube (*outside*) measured in 1/16" increments. For example, a **Hose** specified as **dash 8** or **-8** would have an **inside** diameter of **8/16"** or **1/2"**. Alternatively, a **Tube** specified as **dash 8** or **-8** would have an **outside** diameter of **8/16"** or **1/2"**.

### ORB (O-Ring Boss)

Male ORB fittings have straight UNF threads, a sealing face and an O-ring. The female fittings are generally found in the ports of machines and feature straight threads, a machined surface, and a chamfer to accept the O-ring. Sealing is achieved through the compression of the male O-ring against the chamfered sealing face of the female fitting.

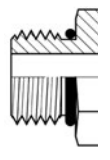
(Lubricated Values)	Dash	Thread Size	Torque	
			Non-Adjustable	Adjustable
	-4	7/16 - 20	30 (40)	15 (20)
	-6	9/16 - 18	35 (46)	35 (46)
	-8	3/4 - 16	60 (80)	60 (80)
	-10	7/8 - 14	100 (135)	100 (135)
	-12	1-1/16 - 12	135 (185)	135 (185)

### Tightening ORB (O-Ring Boss) Fittings

#### Non-adjustable Port End Assembly

1. Inspect the components to ensure that male and female threads and sealing surfaces are free of nicks, burrs, scratches, or any foreign material.
2. Ensure O-Ring seal is properly installed and undamaged.
3. Lubricate threads and O-ring to help the O-ring slide past the port entrance corner and avoid damaging it.
4. Screw the fitting into position tighten to proper torque value from the table shown above.

#### Adjustable Port End Assembly

1. Inspect the components to ensure male & female threads and sealing surfaces are free of nicks, burrs, scratches, or any foreign material.
2. Ensure O-Ring seal is properly installed and undamaged.
3. Lubricate threads and O-ring to help the O-ring slide smoothly into the port and avoid damage.
4. Loosen back the lock nut as far as possible. Make sure back-up washer is not loose and is pushed up as far as possible.
5. Screw the fitting into port until the back-up washer or the retaining ring contacts face of the port. Light wrenching may be necessary. Over tightening may damage washer.
6. To align the end of the fitting to accept incoming tube or hose assembly, unscrew the fitting by the required amount, but not more than one full turn.
7. Using two wrenches, hold the fitting in desired position and tighten the locknut to the proper torque value from the table located above.
8. Inspect to ensure that O-ring is not pinched and that washer is seated flat on the face of the port.

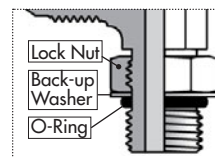

# Service & Maintenance

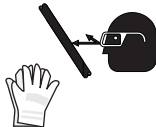

## ⚠ MAINTENANCE SAFETY

- Review the Operator's Manual and all safety items before working with, maintaining or operating the Manure Spreader.
- Stop the tractor engine, place all controls in neutral, set park brake, remove ignition key and wait for all moving parts to stop before servicing, adjusting, repairing or unplugging.
- Keep hands, feet, clothing and hair away from all moving and/or rotating parts.
- Clear the area of bystanders, especially children, when carrying out any maintenance and repairs or making adjustments.
- Place safety stands or large blocks under the frame before removing tires or working beneath the machine.
- Be careful when working around or maintaining a high-pressure hydraulic system. Wear proper eye and hand protection when searching for a high-pressure hydraulic leak. Use a piece of wood or cardboard as a backstop when searching for a pin hole leak in a hose or a fitting. 
- Always relieve pressure before disconnecting or working on hydraulic system.
- When a guard is opened or removed for servicing, be sure to install or close it before starting.

## GREASING

1. Use only a hand-held grease gun for all greasing.
2. Wipe grease fitting with a clean cloth before greasing, to avoid injecting dirt.
3. Replace and repair broken fittings immediately.
4. If fittings will not take grease, remove and clean thoroughly. Also clean lubricant passageway. Replace fitting if necessary.
5. Inject grease until you see grease being expelled from the bearing or bushing areas.

## FLUIDS AND LUBRICANTS

1. Grease: Use an SAE multi-purpose grease with extreme pressure (EP) performance or an SAE multi-purpose lithium base grease. 
2. Gearbox Oil: Use SAE 85W90 gear oil. 
3. Storing Lubricants: Operate at top efficiency by using clean lubricants. Use clean containers for all lubricants. Store them in an area protected from dust, moisture and other contaminants.

## ⚠ SAFETY - DECALS

- Keep safety decals & signs clean and legible at all times.
- Replace safety decals and signs that are missing or have become illegible.
- Replaced parts that displayed a safety sign should also display the current sign.
- Safety decals or signs are available from your Dealer Parts Department. Safety decals will be available upon request.

## REPLACEMENT DECALS

PART NO.	DESCRIPTION	QTY.
<b>Safety Decals</b>		
142358	Decal, Danger - Rotating Part Hazard	4
143306	Decal, Danger - Thrown Objects	3
143315	Decal, Danger - Excessive Vibration	1
143316	Decal, Danger - Lower Gate	1
142383	Decal, Caution - 6 Point Safety	1
142658	Decal, Keep Back 500 ft	2
142900	Decal, Important - Drawbar PTO Setting	1
<b>Reflective Decals</b>		
142556	Red Reflector, 2" x 9"	2
142557	Amber Reflector, 2" x 9"	6
142650	Fluorescent Reflector, 2" x 9"	2
<b>Product Decals</b>		
143204	Decal, Degelman - 11" x 48-3/16"	2
143288	Decal, M28	2
143277	Decal, M34	2
142366	Decal, Rock ByPass System	1
142651	Decal, Patent	1
143162	Decal, Read Manual	1

# Service & Maintenance

## SERVICE INTERVALS

**CAUTION:** Machine may be shown with guard(s) opened for illustrative purposes only. Close all guards before using.

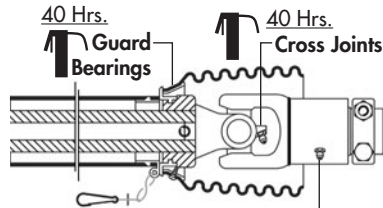
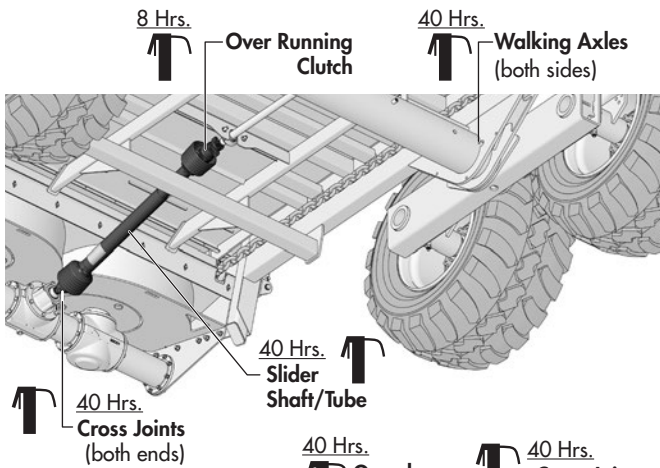
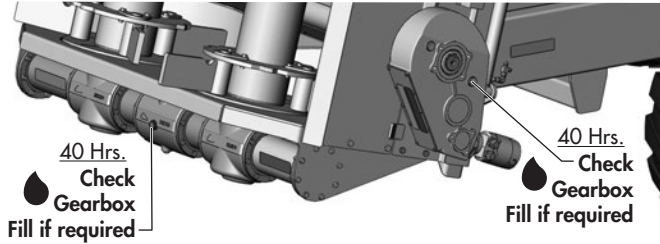

8 Hrs. Over running Clutch (\*5 pumps)

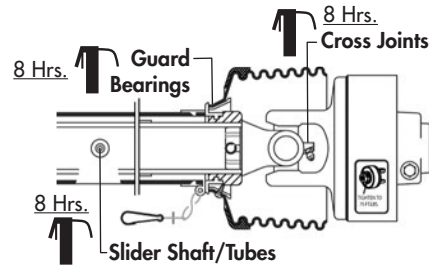

8 Hrs. - 5 pumps

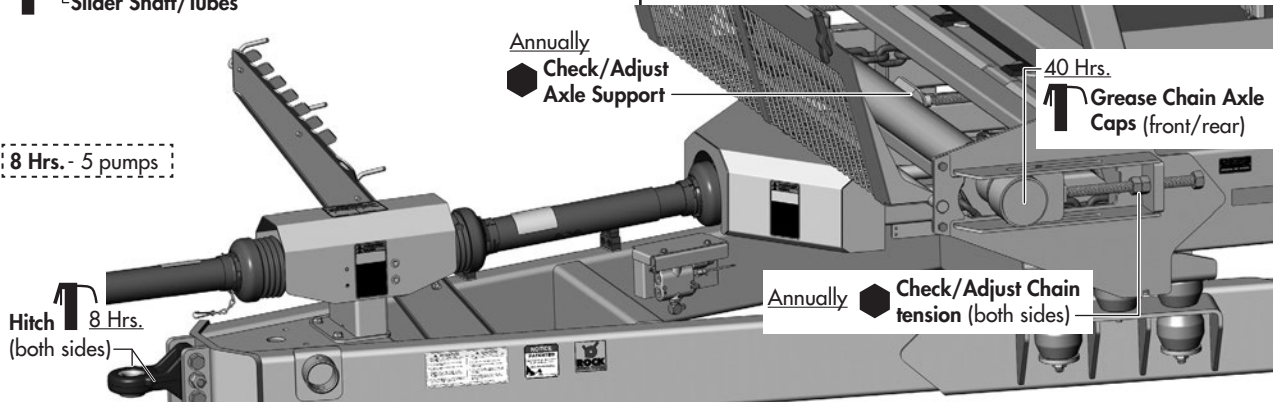

## LUBE AFTER EVERY 8 HRS.

### Initial & after every 8 Hrs.

- check for hydraulic fluid leaks and damaged hoses
- check tire pressure (**65 psi**) / *Optional Tires (58 psi)*
- initial wheel bolt torque (re-check - 2 hrs/8hrs):  
Torque to **505 ft-lbs (683 N-m)** - Dry
- grease front driveline:
  - Over running clutch - (5 pumps)
  - slider shaft/tube - center
  - cross joint fittings - both ends
  - guard bearings - both ends
  - front hitch - both sides

### 40 Hrs./ Weekly

- grease walking axles.
- grease rear driveline:
  - cross joint fittings - both ends
  - slider shaft/tube - center
- grease chain axle endcaps - front/rear
- check gearbox oil levels - 2 gearboxes

Hydraulic Motor Gearbox - Rear right hand side

- Oil should be level with middle of sight glass.
- Add as required through top plug.

Rear Beater PTO Gearbox - Rear, under beaters

- Oil should be level with middle of sight glass.
- Add as required through top plug.
- Oil may take awhile to distribute in casing, re-check level after 30-40 min. Repeat if necessary.

### Annually

- check general hardware/bolt tightness
- check/adjust chain tension

# Service & Maintenance

**⚠ WARNING:** Stop tractor engine, place all controls in neutral, set park brake, remove ignition key and wait for all moving parts to stop before servicing, adjusting, repairing or unplugging.

## GENERAL MAINTENANCE

1. Regularly remove buildup of manure/debris.
2. Vibration during operation may cause fasteners to loosen. Periodically, check all hardware and retighten if necessary.
3. Keep the rear beater paddles and driveline clean. Remove all twine, wire, or other material that may wrap around the beaters or drivelines.
4. On occasion, pressure wash the spreader. Manure is acidic and will damage paint and cause rusting of metal components. Use touch up paint on any chips or scratches.

## BEATER PADDLE/PIN REPLACEMENT

Removing/inspecting the rear beater paddles:

1. Remove and inspect pin bolts and lock nuts.
2. Remove pin and inspect for damage and/or excessive wear.
3. Remove paddle. Inspect bushing & seals for damage and/or excessive wear.

**Note:** It is recommended to replace all three paddles from a row at the same time to maintain proper balance of beater assembly.

4. Replace damaged components and hardware as needed. Reverse procedure for re-installation.
5. When installing/replacing seals, lightly lubricate the seal lips with a bit of grease before insertion.

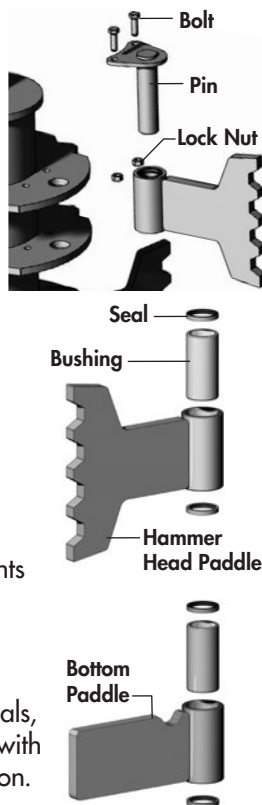

## BEATER ASSEMBLY REPLACEMENT

**⚠ WARNING:** If installing/replacing complete beater assembly, ensure bottom plate timing mark positions of both beater assemblies are opposite (180°) to avoid paddle contact and damage.

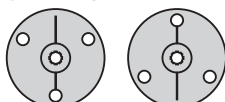

## DRIVELINE REMOVAL - CUT-OUT CLUTCH

The front center driveline is secured onto the driveshaft by tightening a special "Cone-Clamp" bolt located on the Cut-Out Clutch.

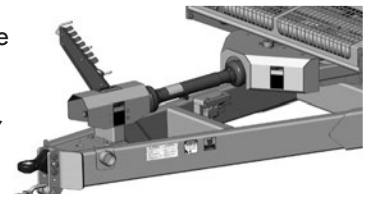

There is a certain procedure for loosening that bolt described below:

1. Insert a punch in the hole opposite the bolt to make contact with the bolt end. Use a hammer to strike the punch approx three times before loosening bolt.
2. Try removing the bolt as usual, if hard to turn, repeat step 1.
3. Remove driveline from shaft.
4. When re-installing driveline, re-torque this bolt to **75 ft-lbf (102 N-m)**. Check and re-torque again after **2 hrs**.

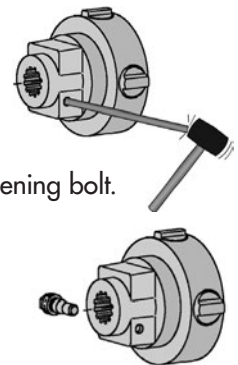

## REPLACING PLASTIC FLOOR SKIDS

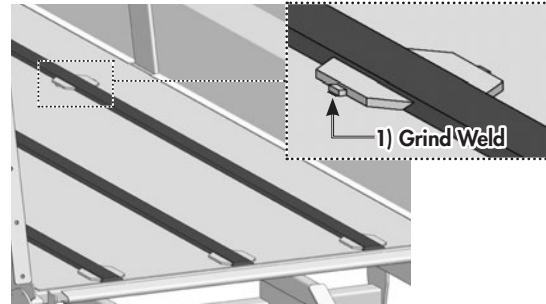

When replacing the plastic floor skids, it is suggested to remove and replace them one at a time to allow the remaining two to help support the drag slats and chain.

1. Grind off the weld holding the ends of the key located on the center skid supports.
2. Remove the key and keep for re-installing new skid.
3. With the key removed, slide out the plastic floor skid from the rear of the machine.

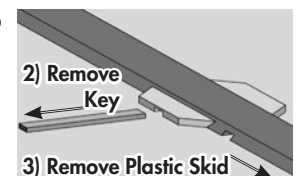

4. Re-install new plastic floor skid and the key in the center support.
5. Repeat above steps for the remaining plastic skids.
6. Tack-weld the ends of the keys back in place.

# Service & Maintenance

## DRAG CHAIN

1. Occasionally check the Drag Chain for any bent or damaged slats. It is important to straighten or replace any damaged slats immediately.
2. The drag chain tension should be checked and adjusted on occasion.

## CENTER STOP ADJUSTMENT

**IMPORTANT:** Whether adjusting chain tension, replacing a slat, or adjusting the Center Support

allow a 1/16" to 1/8" final Gap.



## ADJUSTING CHAIN TENSION

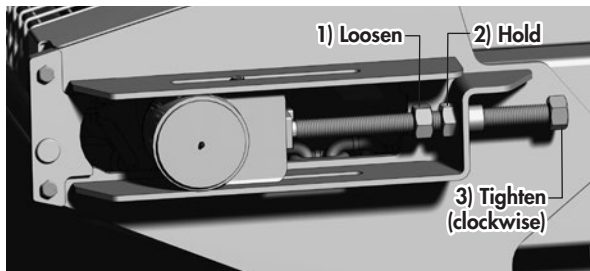

If drag chain has slack, tightening is required:

1. Loosen the jam nut. (*Both sides of machine*)
2. When tightening, hold middle nut with wrench and tighten end of rod in a clockwise direction.
3. a) Starting on one side, tighten the threaded rod a few turns.  
b) Repeat on opposite side of machine to evenly tighten chain tension.  
c) Repeat this procedure 2-3 times until moderate chain tension is achieved.  
d) After advancing the chain with this procedure, check the chain slats at the rear of the machine to ensure they are straight across.  
**Note:** You may need to measure the distance from the round capscrew to the end of the slot. Compare this measurement with the opposite side measurement. Ensure the difference is less than 1/2" MAX to prevent excessive skewing of chain slats.
4. Re-tighten jam nut securely against middle nut.
5. Repeat on other side.
6. Re-adjust center support on front conveyor axle.

## REPLACING A DRAG CHAIN SLAT

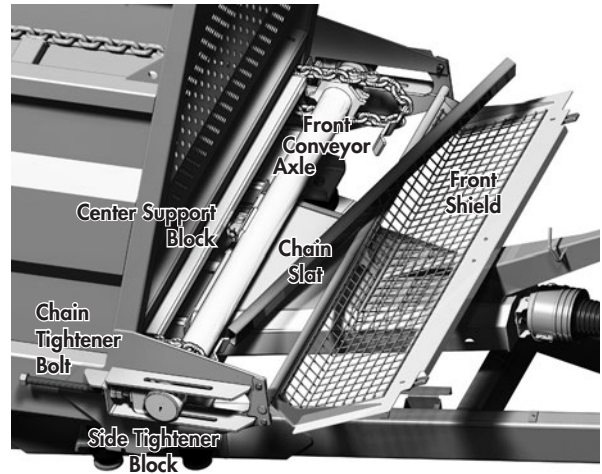

To remove and replace one or more chain slats, follow this procedure:

1. Fully loosen the chain tightener bolts on both side tightener and center support blocks to allow maximum slack in chain.
2. With slackened chain, skew/offset existing damaged chain slat to allow slat holder plates to be removed from the slat ends.

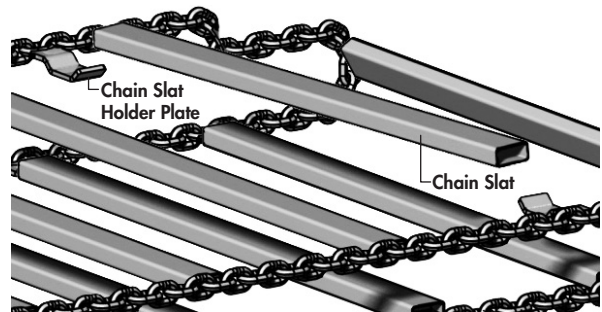

3. Place end of new slat onto existing slat holder plate and skew/offset into position.
4. Repeat with remainder of damaged slats.
5. When finished replacing slats, fully re-tighten the side tightener blocks and firm up center support block against front conveyor axle.
6. Ensure front shield is closed.
7. Check chain tightness after operating and ensure the slats are running straight (*not skewed*). Adjust and tighten as required.

# Service & Maintenance

## WHEEL HUB REPAIR

### DISASSEMBLY

1. Remove dust cap.
2. Remove cotter pin from nut.
3. Remove nut and washer.
4. Pull hub off spindle.
5. Dislodge the inner cone bearing and dust seal.
6. Inspect cups that are press fitted into hub for pits or corrosion and remove if necessary.
7. Inspect and replace defective parts with new ones.

**IMPORTANT:** Be sure to block up unit securely before removing tires.

### COMMON HUB & SPINDLE COMPONENTS



Spindle



Dust Seal



Inner Cone



Inner Cup

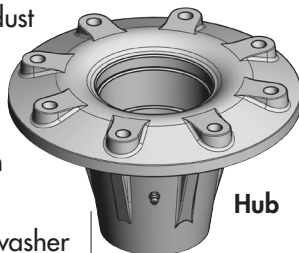

Hub



Outer Cup



Outer Cone



Flat Washer



Slotted Nut & Cotter Pin



Dust Cap

### ASSEMBLY

1. If cups need replacing, be careful to install them gently and evenly into hub until they are fully seated.
2. Apply a thick wall of grease inside hub. Pack grease in cones.
3. Install inner cone and dust seal as illustrated.
4. Position hub onto spindle and fill surrounding cavity with grease.
5. Assemble outer cone, washer and nut.
6. Tighten nut while rotating hub until there is a slight drag.
7. Turn nut back approximately 1/2 turn to align cotter pin hole with notches on nut.
8. Install cotter pin and bend legs sideways over nut.
9. Fill dust cap half full of grease and gently tap into position.
10. Pump grease into hub through grease fitting until lubricant can be seen from dust seal.

## WHEEL NUT & WHEEL BOLT TORQUE



TORQUE

### BOLT PATTERNS



5 BOLT PATTERN

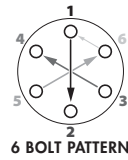

6 BOLT PATTERN

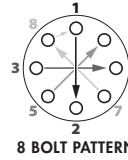

8 BOLT PATTERN

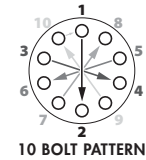

10 BOLT PATTERN

### Recommended Wheel Bolt Torque Specs:

**M22: 505 ft-lbs (683 N-m) -Dry**  
**Note:** Re-check torque on wheel bolts after a couple of hours, and the following day.

### Wheel Tightening Procedure

1. Install and **hand tighten** nuts/bolts.
2. Tighten to approx. **20% Torque** value using the Bolt **Star** or **CrissCross** patterns shown above.
3. Tighten to **Full Torque** value using the **Star** or **CrissCross** pattern.
4. If applicable, install **Rear Locknuts** using **Wheel Torque Values**.

### TIRE SAFETY

1. Failure to follow proper procedures when mounting a tire on a wheel or rim can produce a blow out which may result in serious injury or death.
2. Do not attempt to mount a tire unless you have the proper equipment and experience to do the job.
3. Have a qualified tire dealer or repair serviceman perform required tire maintenance.

# Service & Maintenance

## SPHERICAL BEARING INSTALLATION

### SPHERICAL BEARING COMPONENTS

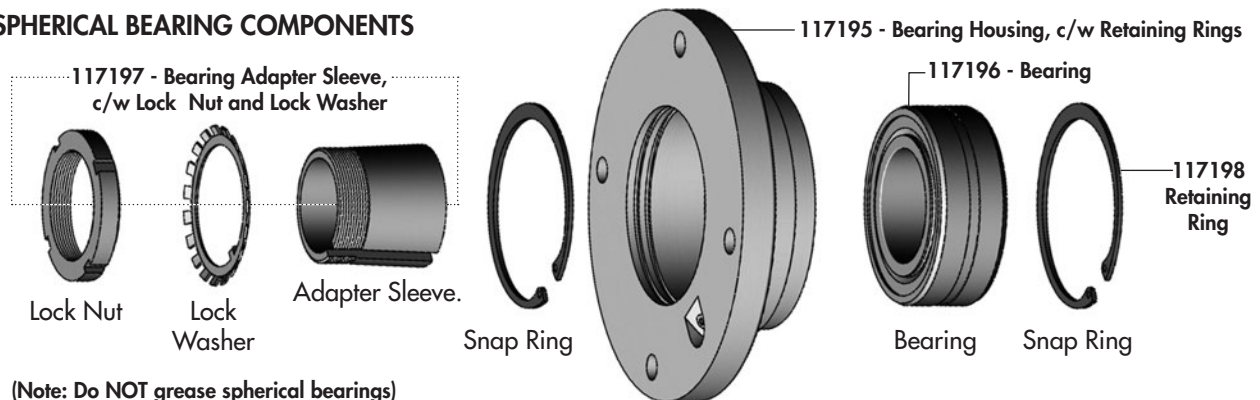

(Note: Do NOT grease spherical bearings)

1. Support and secure beater. Ensure the beater assembly is in the correct position - timing marks rotated 180° opposite to the second beater's timing marks.
2. **IMPORTANT:** Check the position of the snap rings in the assembled bearing unit. They should be located in the "fixed" position (See fig.1). On occasion they have may been sent in the default "floating" position from the supplier but must be relocated to the "fixed" position before installation.  
Note: **Appropriate eye protection should be worn when handling snap rings.**
3. Loosen the locknut almost all the way, with the exception of a few threads to keep it on the sleeve.
4. Push the locknut/sleeve firmly inward against the bearing and hold. While holding, slide the assembly onto the shaft until the bearing housing is in position against the frame (holding the locknut is important so the sleeve doesn't tighten between the bearing and the shaft while sliding into position).
5. Install the bearing mounting hardware loosely then tighten mounting hardware.
6. Hand tighten the locknut and ensure adapter sleeve no longer rotates.
7. Tighten the locknut 1/3 of a rotation or 120°. A hook spanner or a hammer and punch are commonly used. Torque to 140 lb-ft (190 N·m) if possible.
8. Bend one of the tabs on the circumference of the **lockwasher** into the nearest notch on the rim of the locknut. If no tabs line up, tighten the locknut slightly. The locknut should not be loosened in order to align the tab with a notch.

**Bearings come pre-lubricated with Shell Alvania #3 and require no lubrication upon initial installation.**

9. After final assembly of machine, spin beaters to ensure they spin freely.

**Note: Do NOT grease spherical bearings - even if grease fitting is present.**

### REMOVAL INSTRUCTIONS

1. Support and secure beater.
2. To remove the bearing unit from the shaft, raise the bent lockwasher tab, loosen the locknut two or three turns, then tap the nut over its entire circumference with a hammer and punch. Ensure sufficient threads remain engaged as to not damage them. Continue tapping until the adapter sleeve can be moved.
3. Loosen and remove the mounting hardware. Clean outer shaft for easier removal. Slide complete bearing unit off.
3. To remove the bearing insert from the housing, remove one of the snap rings and slide the bearing out.

**Appropriate eye protection should be worn when handling snap rings.**

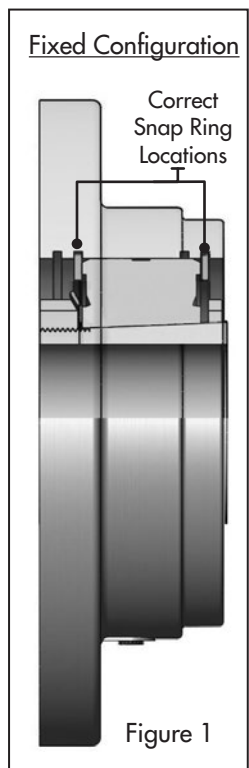

# Service & Maintenance

## HYDRAULIC CYLINDER REPAIR

### PREPARATION

When cylinder repair is required, clean off unit, disconnect hoses and plug ports before removing cylinder.

When removed, open the cylinder ports and drain the cylinder's hydraulic fluid.

Examine the type of cylinder. Make sure you have the correct tools for the job.

You may require the following tools:

- Proper **Seal Kit**
- Rubber Mallet
- Screwdriver
- Punch
- Pliers
- Emery cloth
- Torque Wrench

### Types of Cylinders (Wire Ring / Threaded Head)

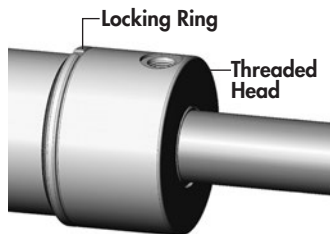
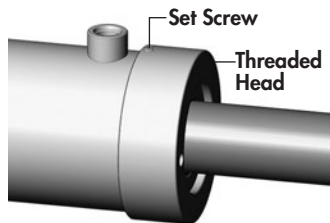
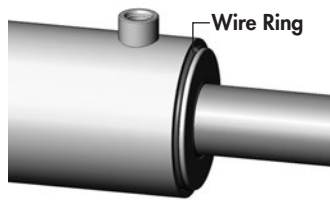

## REPAIRING A WIRE RING CYLINDER

1. Retract the rod assembly.
2. Remove the external steel wire ring.

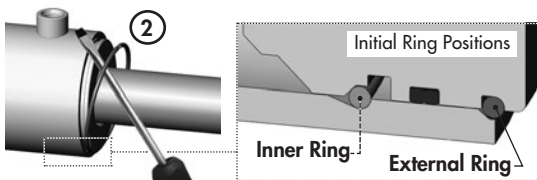

3. Remove any dirt that may have accumulated on the cylinder head.

4. Using the mallet and punch, push the head into the cylinder tube until the internal tube groove is fully exposed. This will also move the internal wire ring into its removal position.



5. Take the plastic removal ring from the seal kit:
  - a) Straighten the ring and remove any kinks or excessive curl to make installation easier and prevent it from falling out.
  - b) Insert the removal ring into the internal groove with the feathered end pointing into the tube.

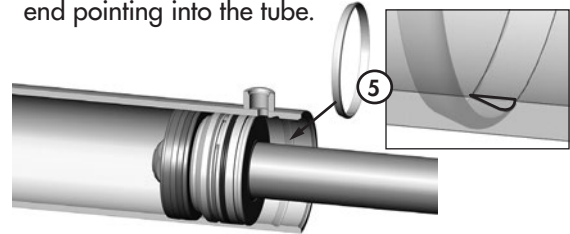

- c) Use a screwdriver or a finger to hold one end of the ring in the groove while fitting the other end of the ring into the groove. The tips should snap in together. Ensure it is secure and fully seated before the next step.

**IMPORTANT:** It is important to ensure the removal ring is completely in the groove before pulling the rod out. If the ring sticks out it will get stuck between the head and tube.

6. a) Extend the rod to pull head out of tube. If the rod does not pull out easily, push the head back in and ensure the ring is properly in the groove. Replace ring if necessary.

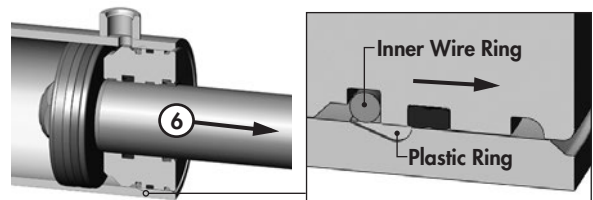

**Note:** Excessive force will not overcome a jammed ring and could damage the cylinder.

7. Remove plastic removal ring from the cylinder tube.





# Service & Maintenance

8. Remove locknut, piston and head from rod.

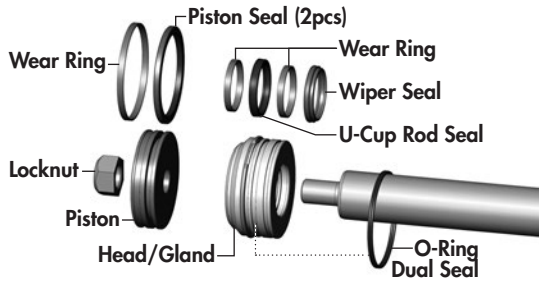

9. a) Inspect and replace all of the seals with new components.  
 b) Inspect the inside of the cylinder barrel, piston, rod and other polished parts for burrs and scratches. Smooth areas as needed with an emery cloth.  
 c) During re-assembly of head/gland assembly, leave the outer O-Ring Dual Seal loose on the rod to re-install at a later step.

10. Replace piston and torque the locknut to required value. (Refer to chart below)

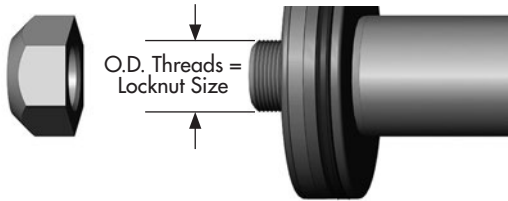

LOCKNUT SIZE (PISTON)	TORQUE VALUE
3/8 - 24 UNF	25-30 lb.ft (35-42 N.m)
1/2 - 20 UNF	40-60 lb.ft (55-80 N.m)
5/8 - 18 UNF	95-105 lb.ft (130-140 N.m)
3/4 - 16 UNF	175-225 lb.ft (240-305 N.m)
7/8 - 14 UNF	200-275 lb.ft (270-370 N.m)
1 - 14 UNF	300-380 lb.ft (405-515 N.m)
1 1/8 - 12 UNF	400-500 lb.ft (540-675 N.m)
1 1/4 - 12 UNF	500-600 lb.ft (675-810 N.m)
1 1/2 - 12 UNF	700-800 lb.ft (950-1085 N.m)
1 3/4 - 12 UNF	800-900 lb.ft (1085-1220 N.m)

11. a) Install the supplied band clamp to compress the inner wire ring on the head/gland assembly so it will fit into the tube.  
**Note:** Make sure the cam of the band clamp is not overtop of the gap in the ring.

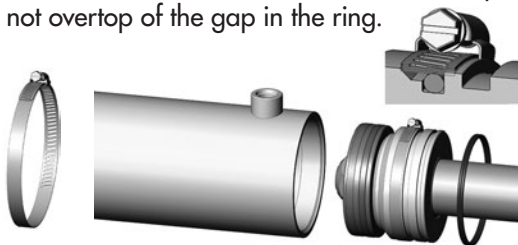

b) Tighten the band clamp to ensure the wire ring is fully seated. Then, loosen the clamp approx. 1/2 a turn to allow band clamp to slide during final assembly.

12. Lubricate the cylinder tube and piston seals.

13. Insert the piston into the tube. Tap the cylinder head into the tube until the clamp slides over and the inner wire ring is inside the tube.

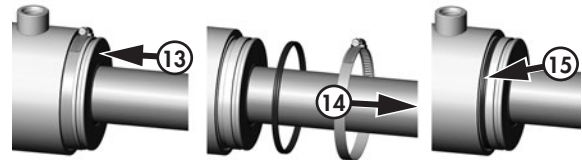

14. Loosen the clamp and remove.

15. Install the O-Ring Dual seal.

16. Tap the head the rest of the way until the end is flush with the tube.

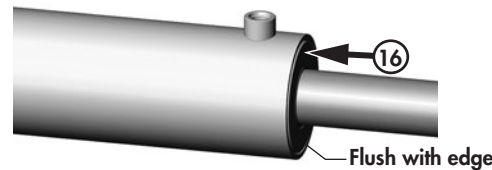

**IMPORTANT:** The head/gland must be inserted until it is flush with the tube to allow the inner wire ring to snap into its seated position in the internal cylinder groove. Failure to insert the head flush as shown will result in the head and rod assembly coming out of the tube when pressure is applied to the cylinder.

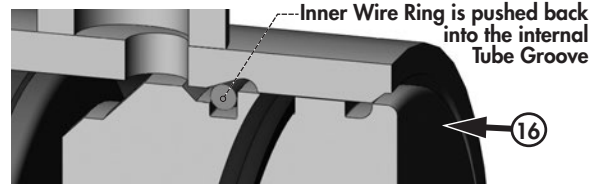

17. Pull the rod out to expose the external wire ring groove in cylinder head, and then install the external ring.

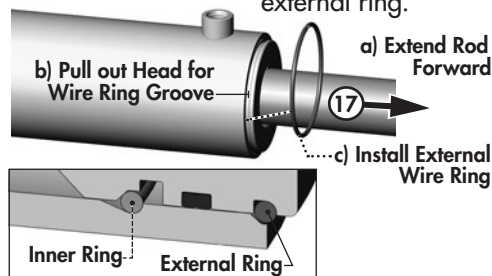

18. Before using the cylinder, ensure that you double check your work.

# Service & Maintenance

## REPAIRING A THREADED HEAD CYLINDER

### Set Screw Style

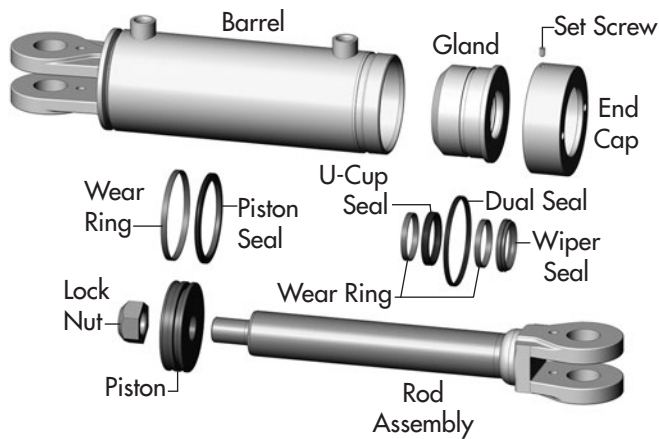

#### DISASSEMBLY

1. Loosen Set Screw and turn off end cap.
2. Carefully remove piston/rod/gland assemblies.
3. Disassemble the piston from the rod assembly by removing lock nut.

**NOTE:** DO NOT clamp rod by chrome surface.

4. Slide off gland assembly & end cap.
5. Remove seals and inspect all parts for damage.
6. Install new seals and replace damaged parts with new components.
7. Inspect the inside of the cylinder barrel, piston, rod and other polished parts for burrs and scratches. Smooth areas as needed with an emery cloth.

#### REASSEMBLY

1. Reinstall rod through end cap & gland assembly.
2. Secure piston to rod with lock nut. Torque lock nut to proper value (refer to chart on previous page for proper torque value).
3. Lube inside of barrel, piston seals, and gland seals with hydraulic oil.
4. With cylinder body held gently in a vise, insert piston, gland, end cap and rod combination using a slight rocking motion.
5. Apply Loctite anti-seize before installing cylinder end cap.
6. Torque cylinder end cap to 440 lb.ft (600 N.m).
7. Tighten Set Screw on end cap to 6 lb.ft (8 N.m).

## REPAIRING A THREADED HEAD CYLINDER

### Locking Ring Style

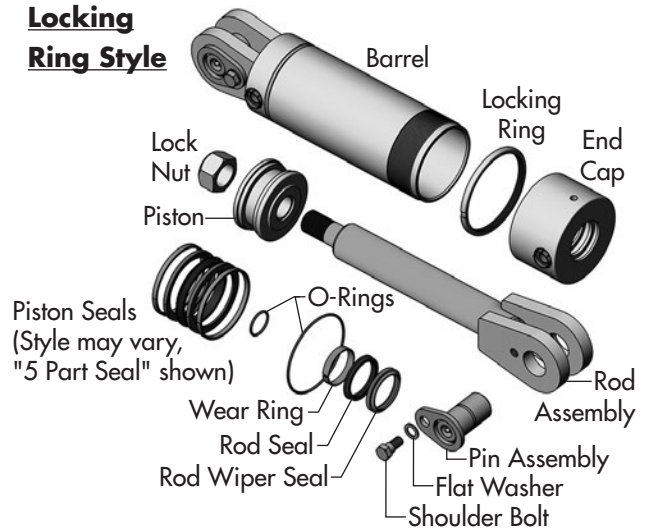

#### DISASSEMBLY

1. Loosen Locking Ring and turn off end cap.
2. Carefully remove piston, rod and end cap.
3. Disassemble the piston from the rod assembly by removing lock nut.

**NOTE:** DO NOT clamp rod by chrome surface.

4. Slide off end cap.
5. Remove seals and inspect all parts for damage.
6. Install new seals and replace damaged parts with new components.
7. Inspect the inside of the cylinder barrel, piston, rod and other polished parts for burrs and scratches. Smooth areas as needed with an emery cloth.

#### REASSEMBLY

1. Reinstall rod through end cap.
2. Secure piston to rod with lock nut. Torque lock nut to proper value (refer to chart on previous page for proper torque value).
3. Thread lock ring fully onto barrel.
4. Lube inside of barrel and piston seals with hydraulic oil.
5. With cylinder body held gently in a vise, insert piston, end cap and rod combination using a slight rocking motion.
6. Turn end cap fully against lock ring then back off end cap to align ports.
7. Tighten Locking Ring against end cap using a punch and hammer.

# Troubleshooting

## TROUBLESHOOTING

In the following section, we have listed some of the problems, causes and solutions that you may encounter. If you encounter a problem that is difficult to solve, even after having read through this troubleshooting section, please call your local dealer or distributor. Before you call, have this manual and the serial number from your unit ready.

PROBLEM	CAUSE	SOLUTION
<b>Chain came off sprocket.</b>	Freezing conditions.	Always check to make sure chain is not frozen before operating.
	Bent drag chain slat.	Replace bent or damaged slats.
	Loose chain.	Tighten chain. (Refer to Maintenance Section)
<b>Oil accumulation on cylinder shaft.</b>	External hydraulic leak.	Disconnect & blow out lines with compressed air.
	Hydraulic cylinder leak.	Repair as needed.
<b>Hydraulics are on but floor chain won't engage.</b>	Control box not properly connected or turned on.	Flow control box must have power and be "on" in order to operate the floor chain.
<b>PTO disengaged and beaters stopped working.</b>	Rear beaters were jammed, plugged, or stalled causing driveline clutch to disengage.	PTO must be slowed to under 500 RPM before clutch will re-engage. Refer to "unplugging" procedure found on page 10 for more info.
<b>PTO driveline is rattling or making short, sharp knocking sounds</b>	Equal angle driveline requires proper distance /angle setting to prevent damage or failure.	The manure spreader's "Front PTO bearing bracket" and/or the tractor "PTO to Hitch Pin" distance may need to be adjusted. Check with the section on "Preparation" to confirm and check the setting for your 1-3/4" - or - 1-3/8" PTO driveline.

# Parts Section

## PARTS SECTION - TABLE OF CONTENTS

<b>Overview</b>	<b>24</b>
Frame Components	25
Walking Axle & Wheel Components	26
Hitch Pole Components	28
Rear Gate Components	29
Front Shield Components	30
Chain & Tightener Components	31
Rear Axle & Gearbox Components	32
Rear Frame & Beater Components	35
Rear Beater Gearbox Components	38
Driveline Components	39
Hydraulic Routing	42
Electrical Components	45
Side Extensions (Optional)	47
Skid Plate Kits (Optional)	48
<b>Warranty</b>	<b>49</b>

**IMPORTANT:**



**READ MANUAL**

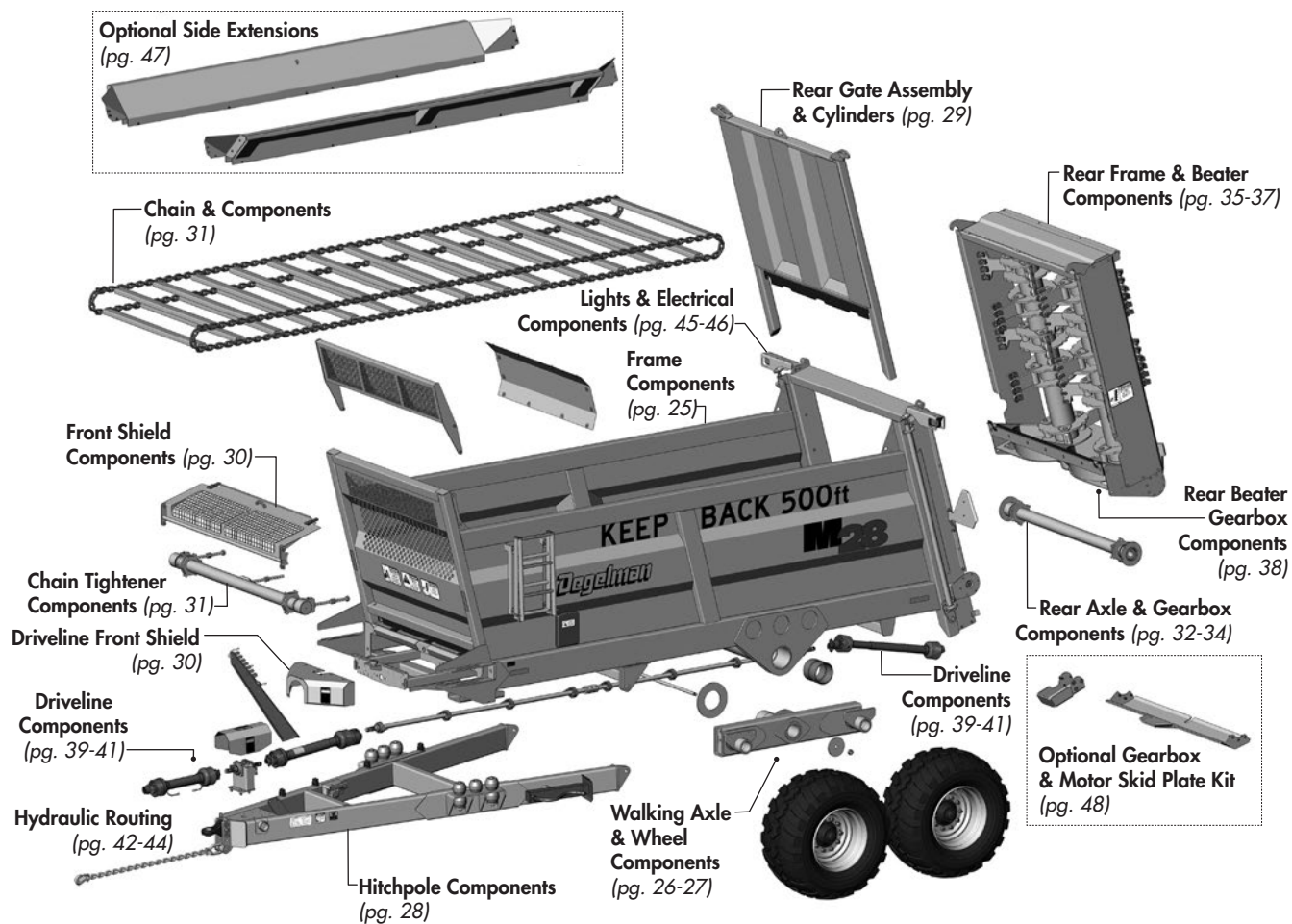

# Frame Components

## FRAME COMPONENTS

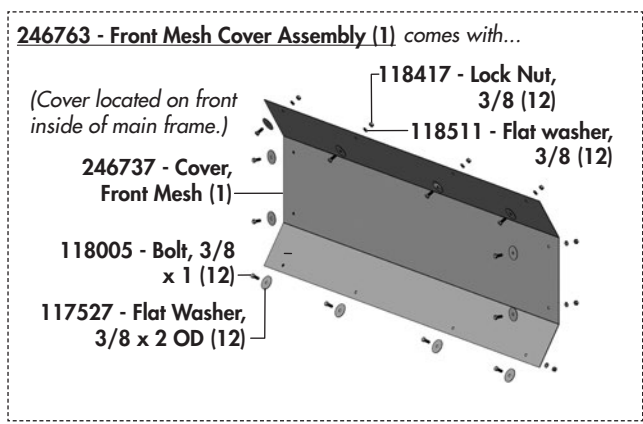
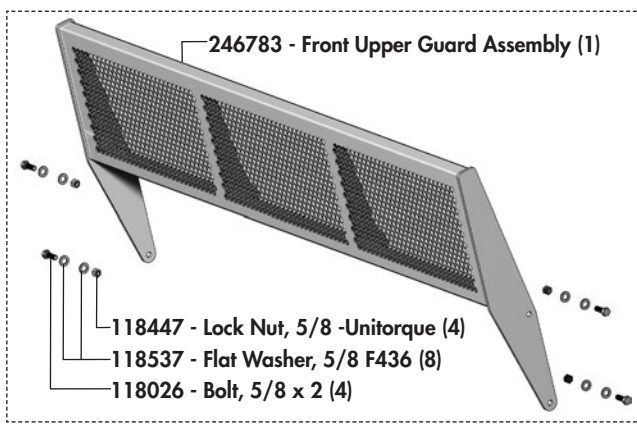
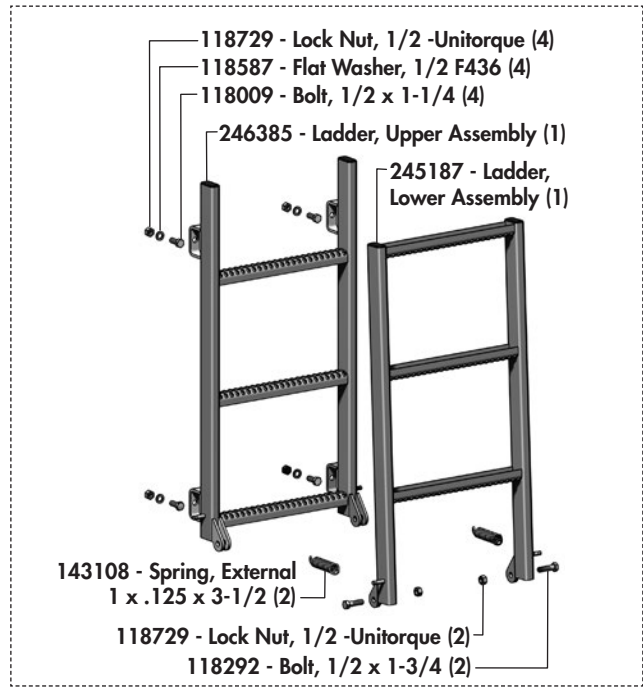
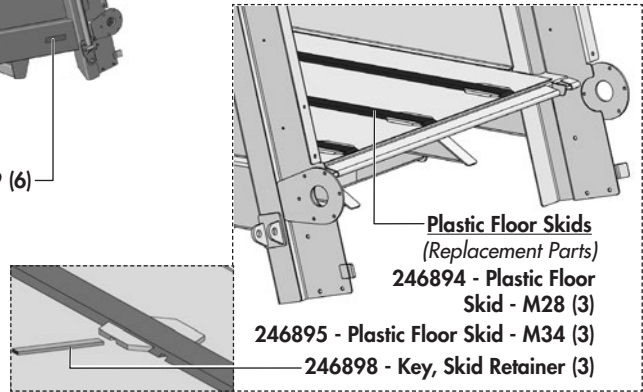
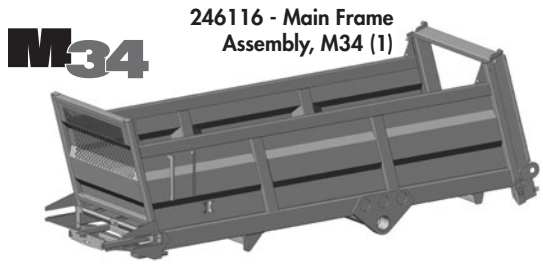
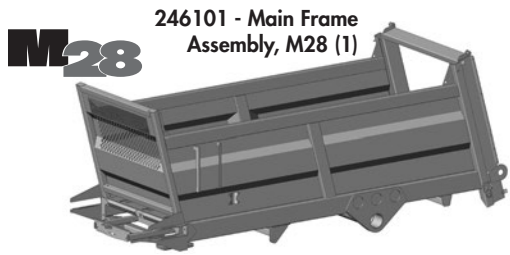
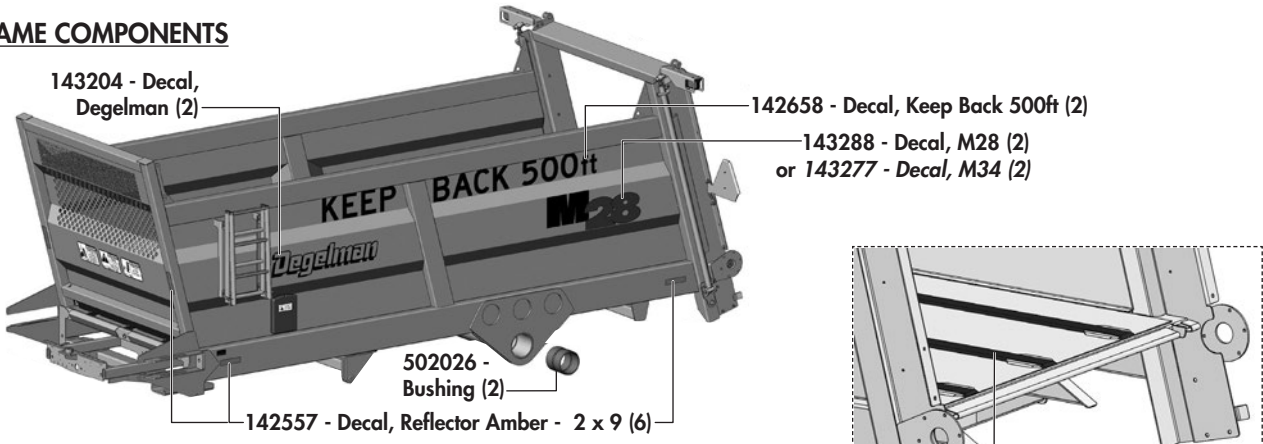

# Walking Axle & Wheel Components

## WALKING AXLE COMPONENTS - STANDARD

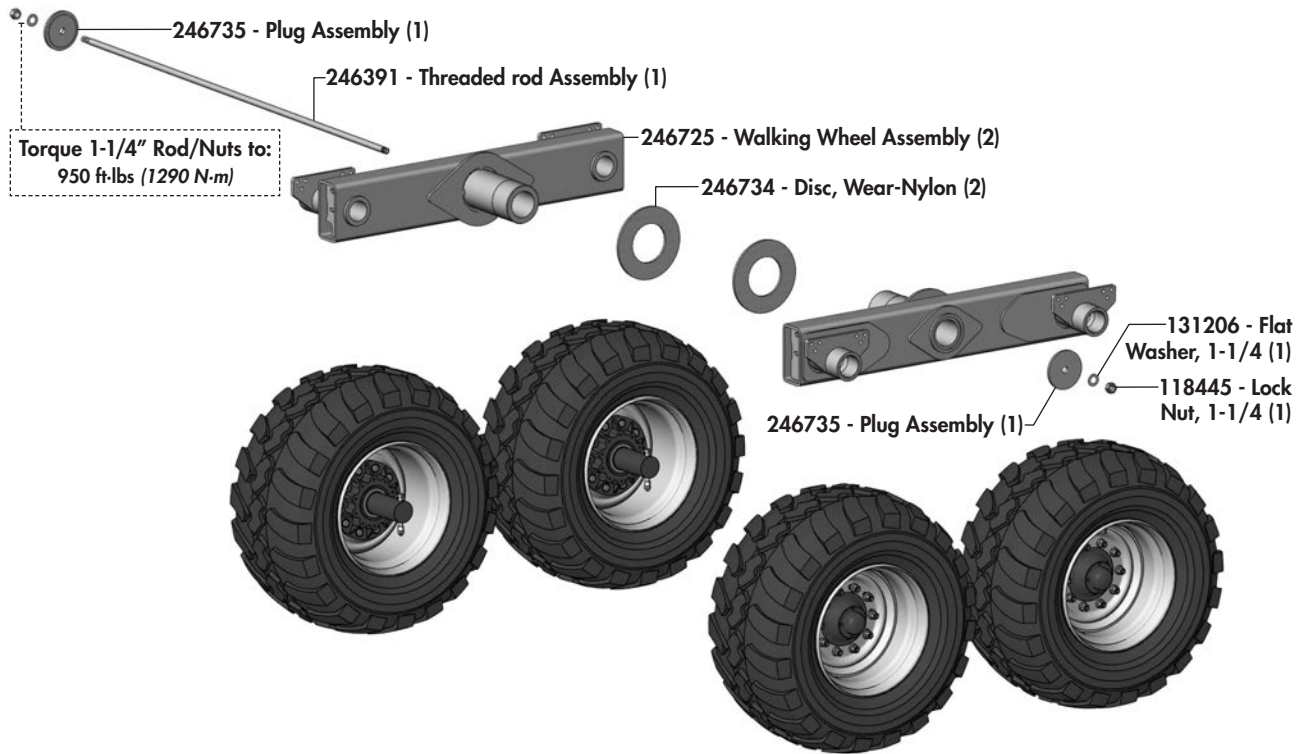

## WHEEL COMPONENTS - STANDARD

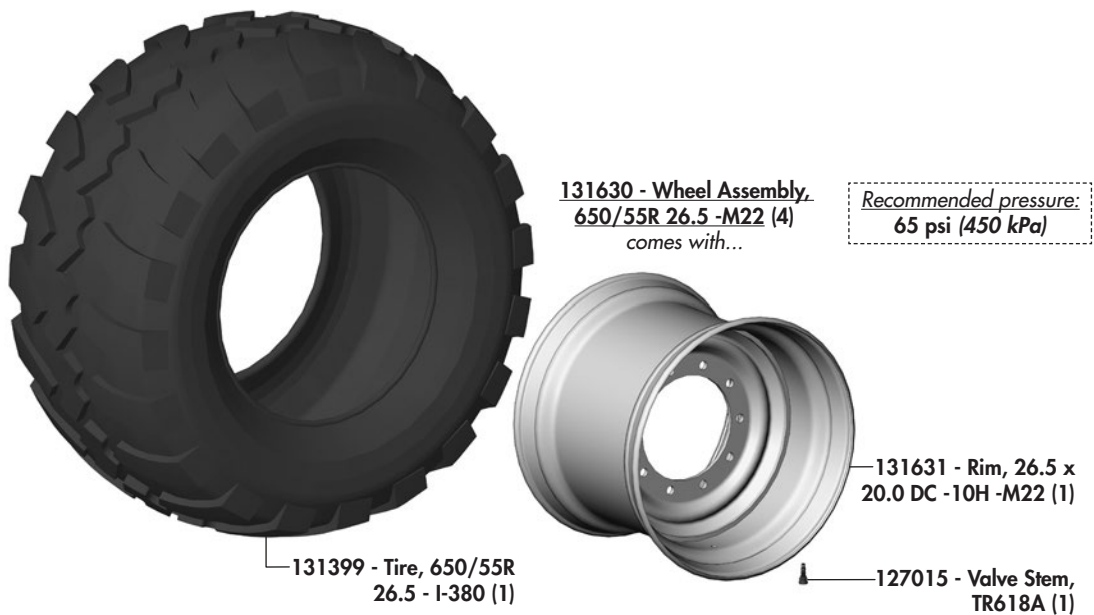

# Walking Axle & Wheel Components

## OPTIONAL - MUCK MASTER & MUCK MASTER HD WHEEL/AXLE PACKAGES

**Note:** The Muck Master & Muck Master HD wheel package options replace the tires, walking axle assemblies, and wear washers only. Other items including spindles, rod assembly and hardware are the same as the standard tire option.

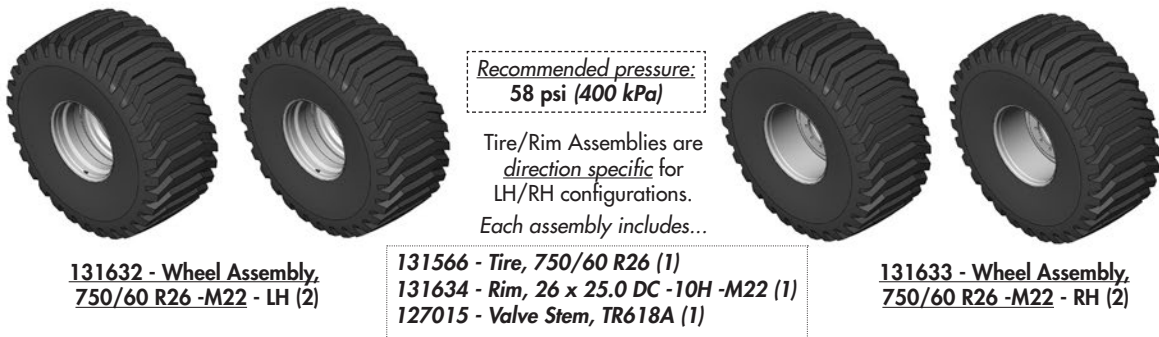
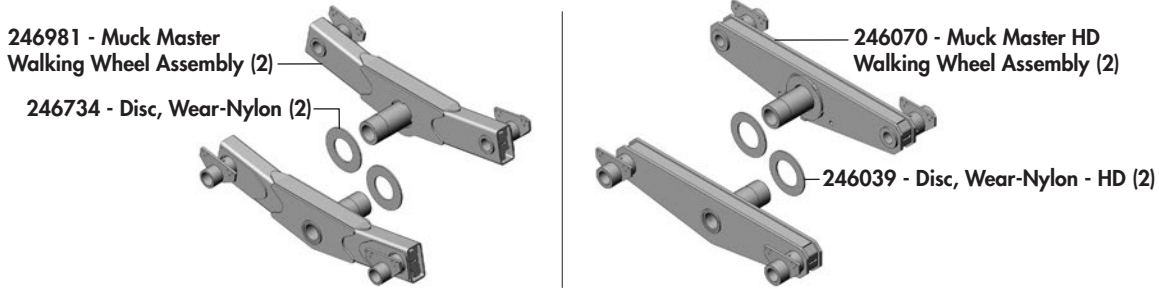

## HUB/SPINDLE COMPONENTS

131430 - Hub/Spindle Assembly (4) comes with...

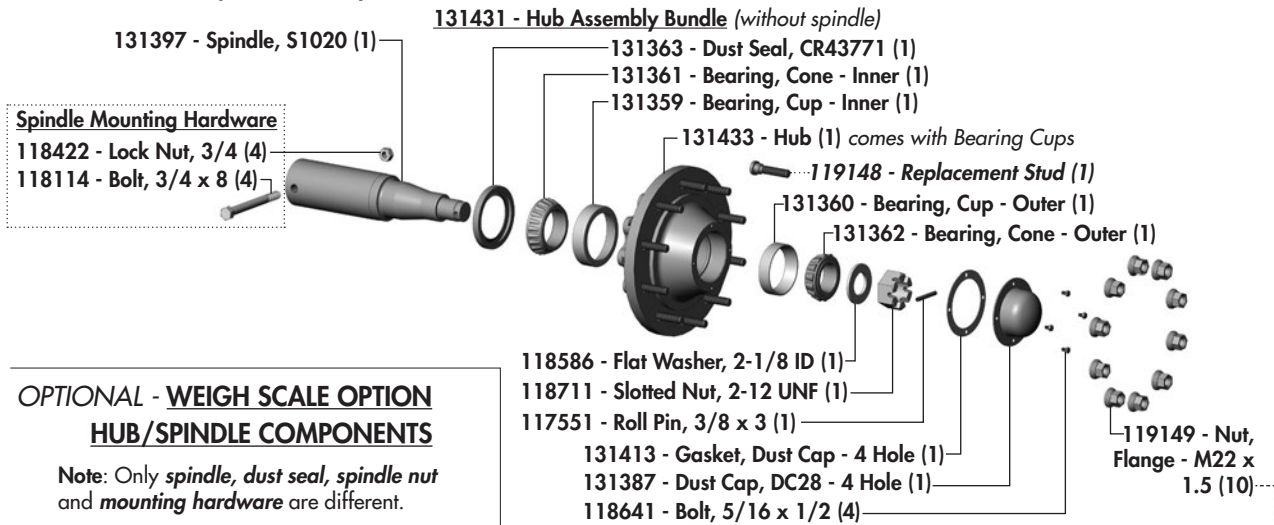

## OPTIONAL - WEIGH SCALE OPTION HUB/SPINDLE COMPONENTS

**Note:** Only *spindle, dust seal, spindle nut* and *mounting hardware* are different.

131434 - Hub/Spindle Assembly (4) comes with...

131760 - Weigh Scale Spindle (1)

**Spindle Mounting Hardware**  
118447 - Lock Nut, 5/8 (4)  
118039 - Bolt, 5/8 x 8 (4)

131431 - Hub Assembly Bundle (without spindle)

131411 - Dust Seal, Weigh Scale Option (1)

(Other components are same as above.)

131412 - Slotted Nut, 2 UNF (1)

**Recommended Wheel Bolt Torque Specs:**

505 ft-lbs (683 N-m) - dry

**Note:** Re-check torque on wheel bolts after a couple of hours, and the following day.

# Hitch Pole Components

## HITCH POLE COMPONENTS

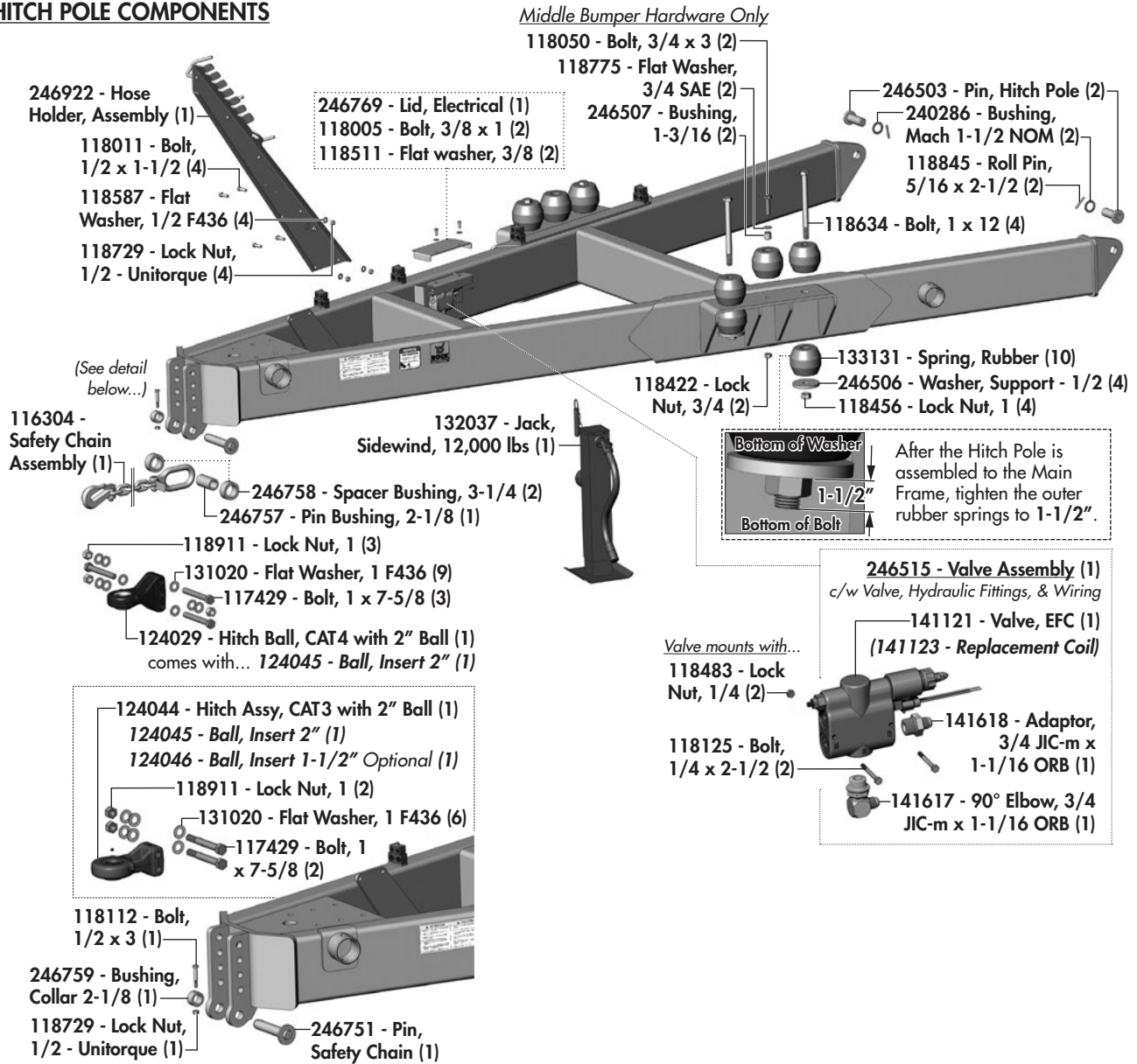



# Rear Gate Components

## REAR GATE COMPONENTS

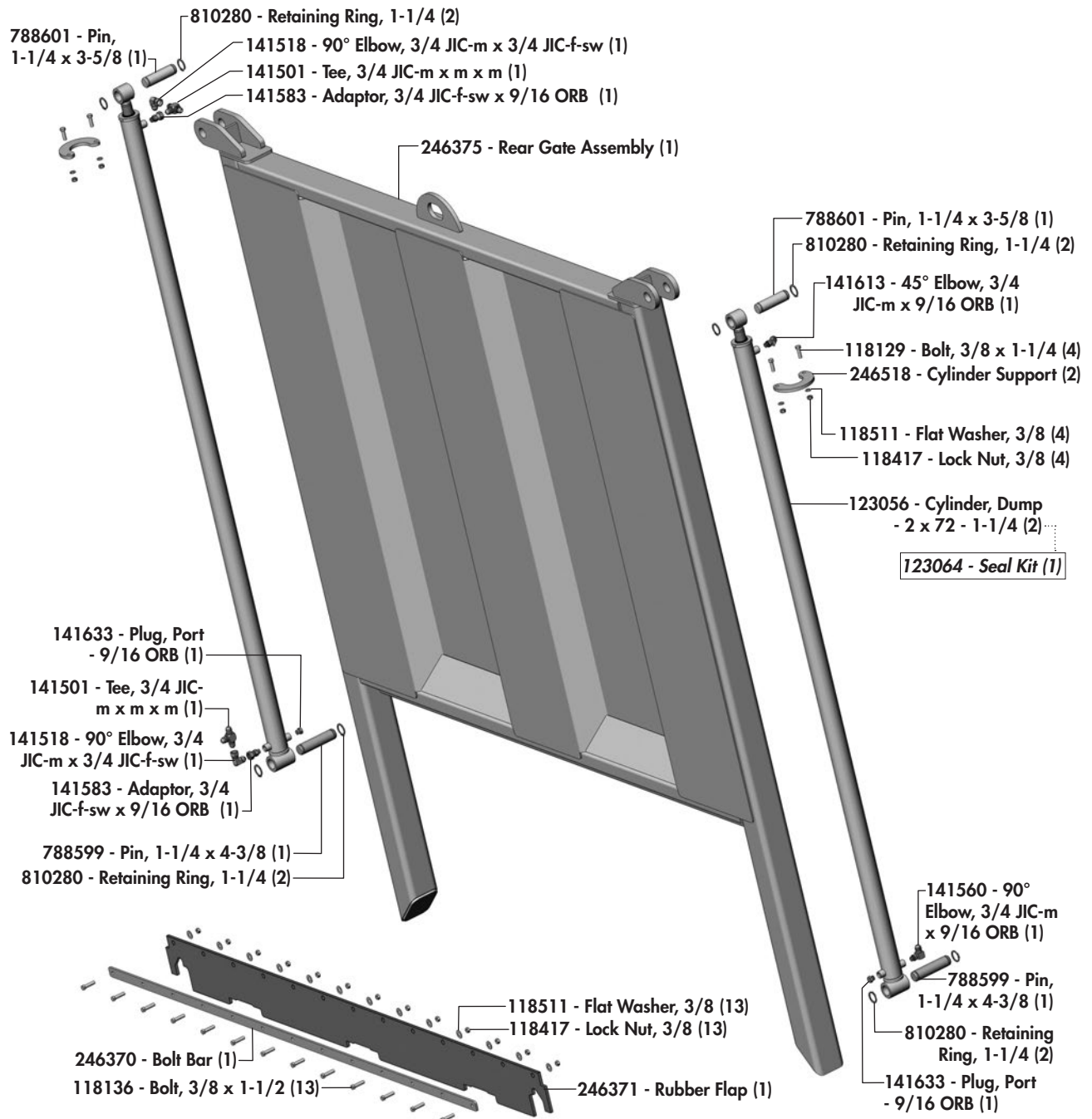

# Front Shields / Components

## FRONT SHIELDS / COMPONENTS

**246409 - Front Shield, Assembly (1)**  
comes with handle and latches...

133093 - Capscrew, SH M8 x 1.25 x 30mm (2)  
133092 - Handle (1)  
133094 - Nut, M8 x 1.25 (2)

129085 - Latch, Draw (2)  
118998 - Mach Screw, #10-24 x 1/2" (4)  
118999 - Lock Washer, #10 (4)  
118000 - Nut, #10-24 UNC (4)

246403 - Shield Pin Assembly, RH (1)  
246404 - Shield, Pin Assembly, LH (1)

118447 - Lock Nut, 5/8 - Unitorque (4)  
118537 - Flat Washer, 5/8 - F436 (4)  
118026 - Bolt, 5/8 x 2 (4)

117479 - Bolt, 3/8 x 2-1/4 (1)  
118511 - Flat washer, 3/8 (1)  
792040 - Rubber Bumper (1)  
118511 - Flat washer, 3/8 (1)  
118417 - Lock Nut, 3/8 (1)

118009 - Bolt, 1/2 x 1-1/4 (2)  
118587 - Flat Washer, 1/2 F436 (2)

246699 - Shield, Assembly (1)  
249150 - Shield, Assembly (1)

118511 - Flat washer, 3/8 (8)  
118005 - Bolt, 3/8 x 1 (4)  
118417 - Lock Nut, 3/8 (4)

118027 - Bolt, 5/8 x 2-1/4 (4)  
118537 - Flat Washer, 5/8 F436 (8)  
118447 - Lock Nut, 5/8 - Unitorq (4)

246695 - Front PTO, Bearing Bracket (1)

Refer to *Driveline Components* section for bearing & shaft parts.

142366 - Decal, Rock Bypass System (1)  
142651 - Decal, Patent (1)  
142383 - Decal, Caution - 6 Point Safety (1)

142900 - Decal, Important PTO Drawbar Setting (1)  
142358 - Decal, Danger Rotating Part Hazard (2)

Bottom of Washer  
1-1/2"  
Bottom of Bolt

After the Hitch Pole is assembled to the Main Frame, tighten the outer rubber springs to 1-1/2".

**WARNING:** The front PTO driveline is an equal angle driveline that requires proper positioning to prevent damage or failure.

Front PTO Bearing Holder

**WARNING**  
B-C Rear Position for 1-3/4" PTO Driveline  
A-B Forward Position 1-3/8" PTO Driveline

16 inches

1-3/8 - 21 Spline

20 inches

1-3/4 - 20 Spline

# Chain & Tightener Components

## FRONT CONVEYOR & TIGHTENER COMPONENTS

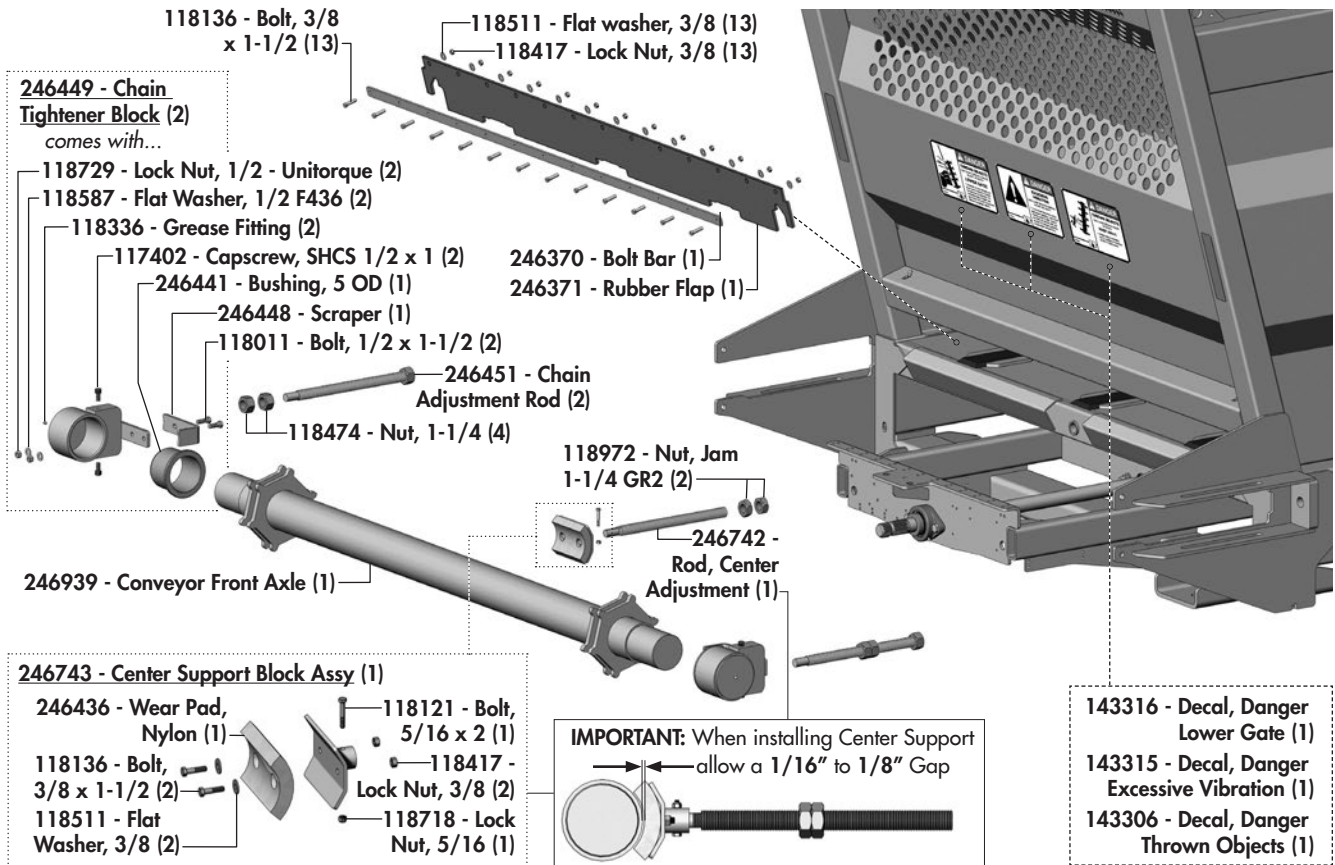

## CHAIN ASSEMBLY COMPONENTS

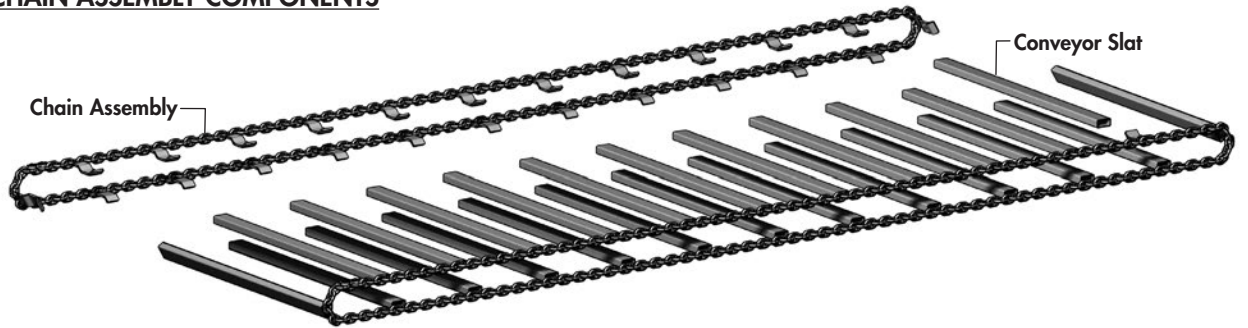

Models SN MS1277 and up

- 246856 - Chain Assembly, M28, 28 Slat Holder (2)
- 246891 - Chain Assembly, M34, 33 Slat Holder (2)
- 246425 - Conveyor Slat ( M28- 28 or M34- 33)

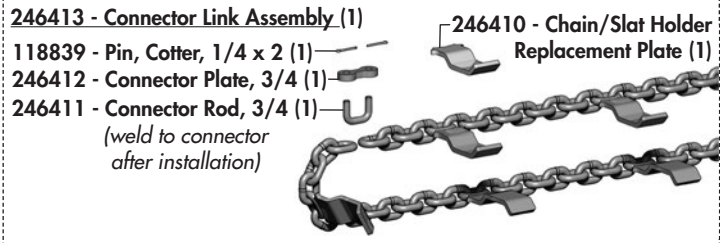

# Rear Axle & Gearbox Components

## REAR DRIVE AXLE COMPONENTS (Dual Drive Ready)

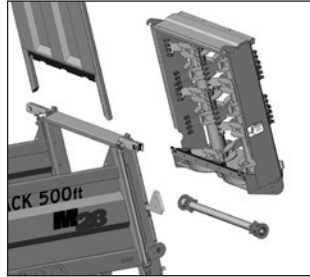
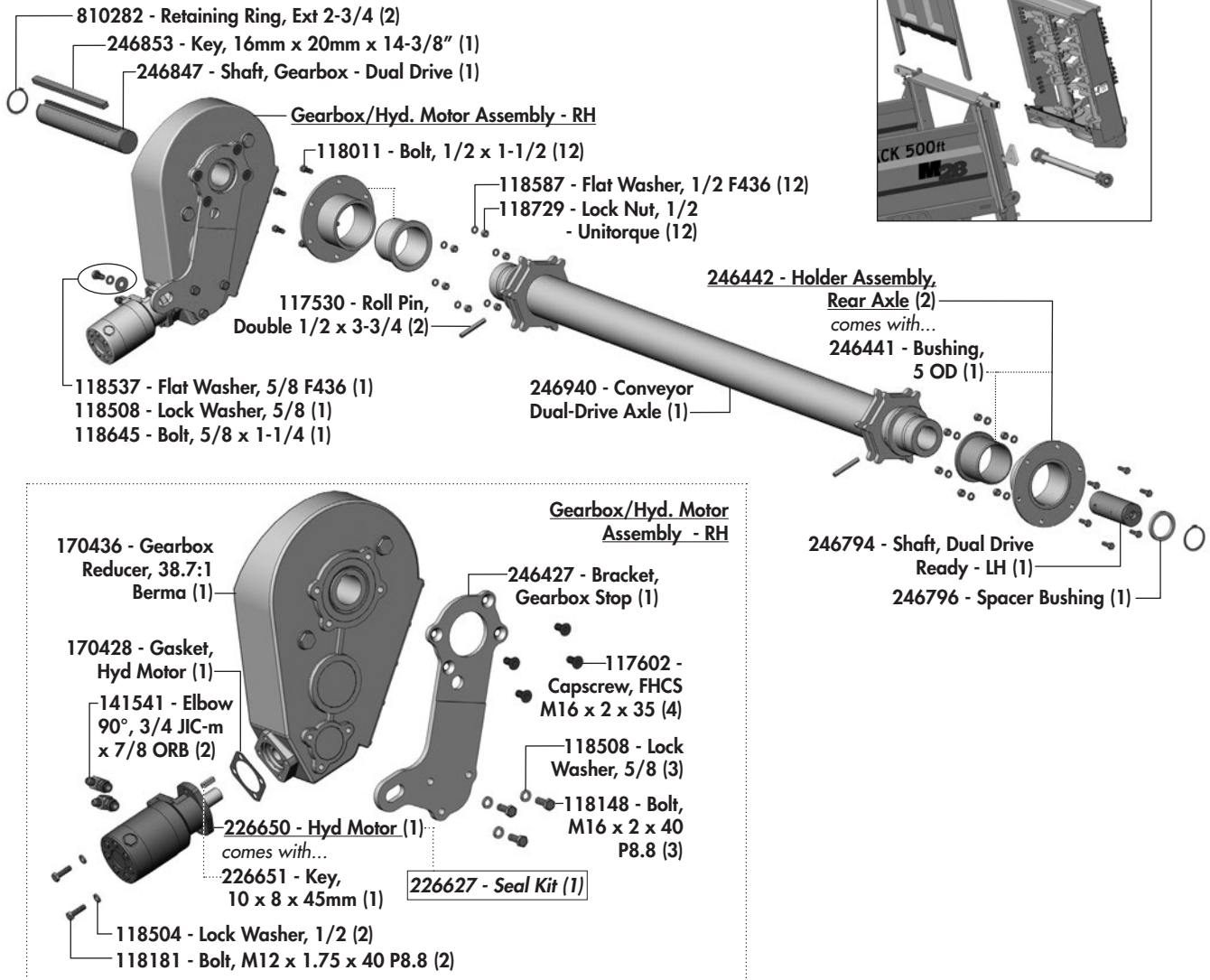

# Rear Dual Drive Conversion Kits

## 246793 - Dual Drive Conversion Kit

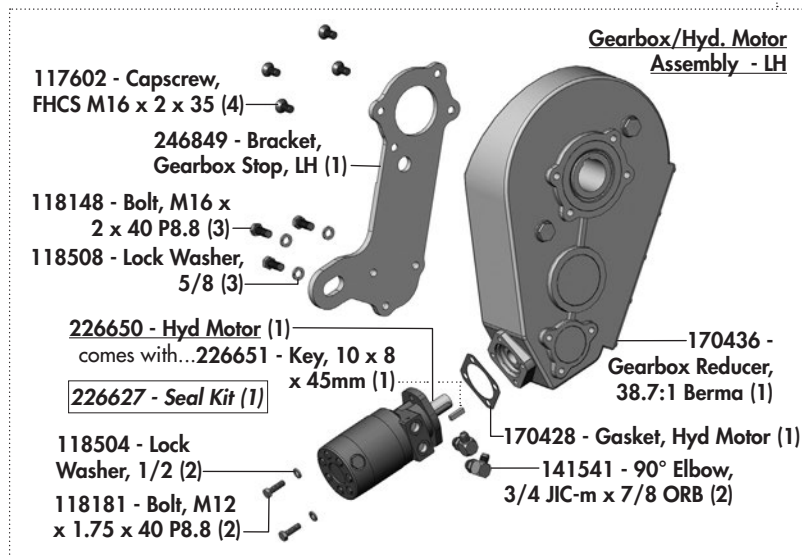
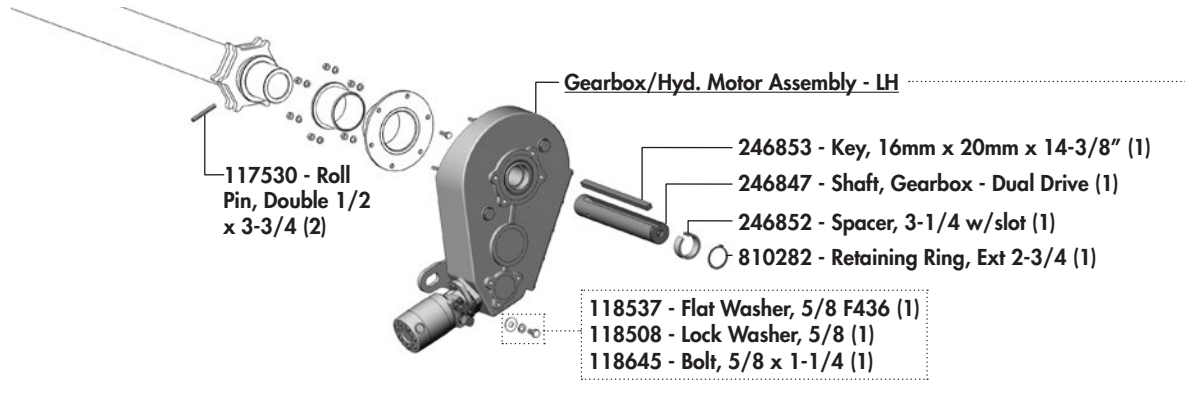

# Rear Axle Gearbox Components

## INTERNAL GEARBOX COMPONENTS

170436 - Gearbox Reducer, 38.7:1 Berma (1) comes with...

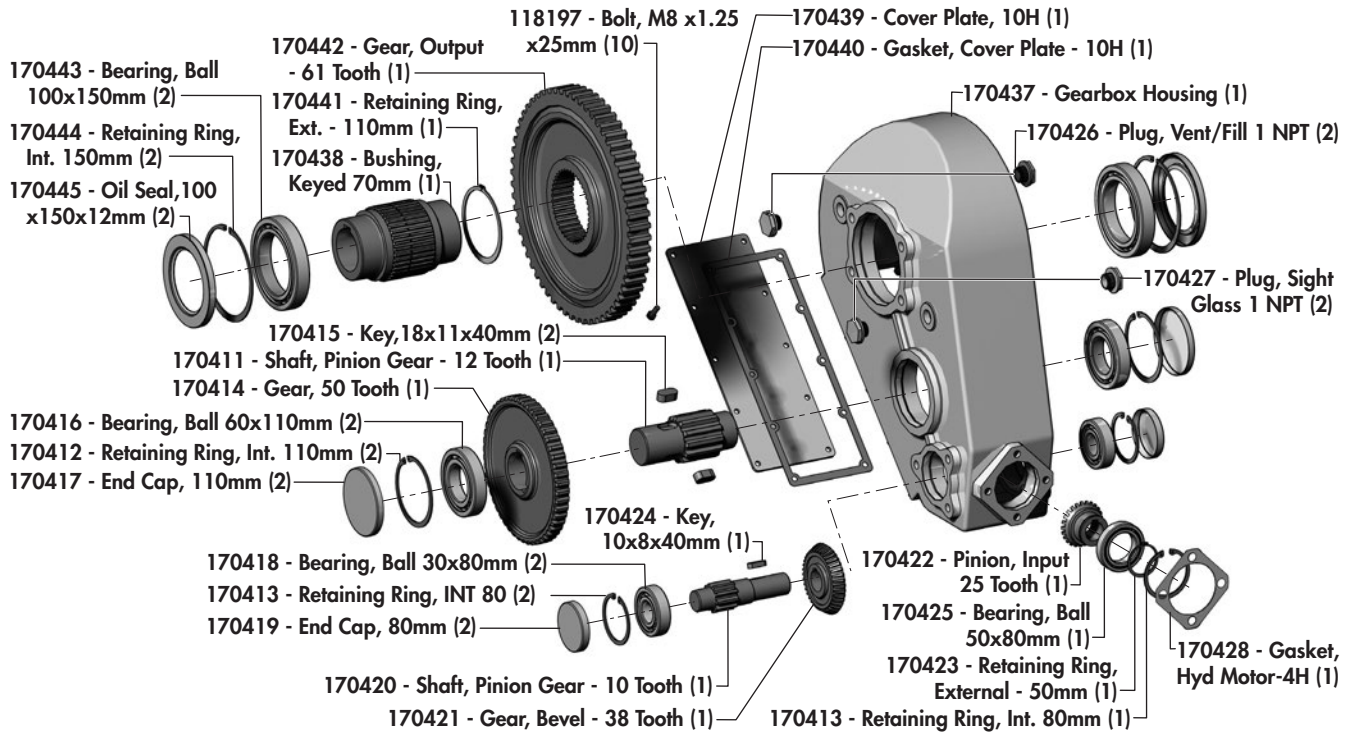

# Rear Frame & Beater Components

## REAR BEATER FRAME ASSEMBLY COMPONENTS

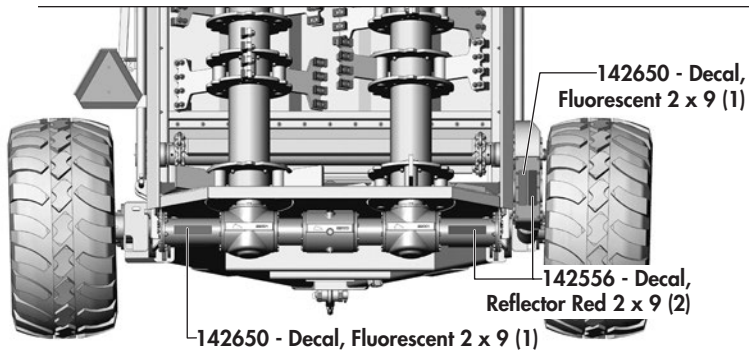
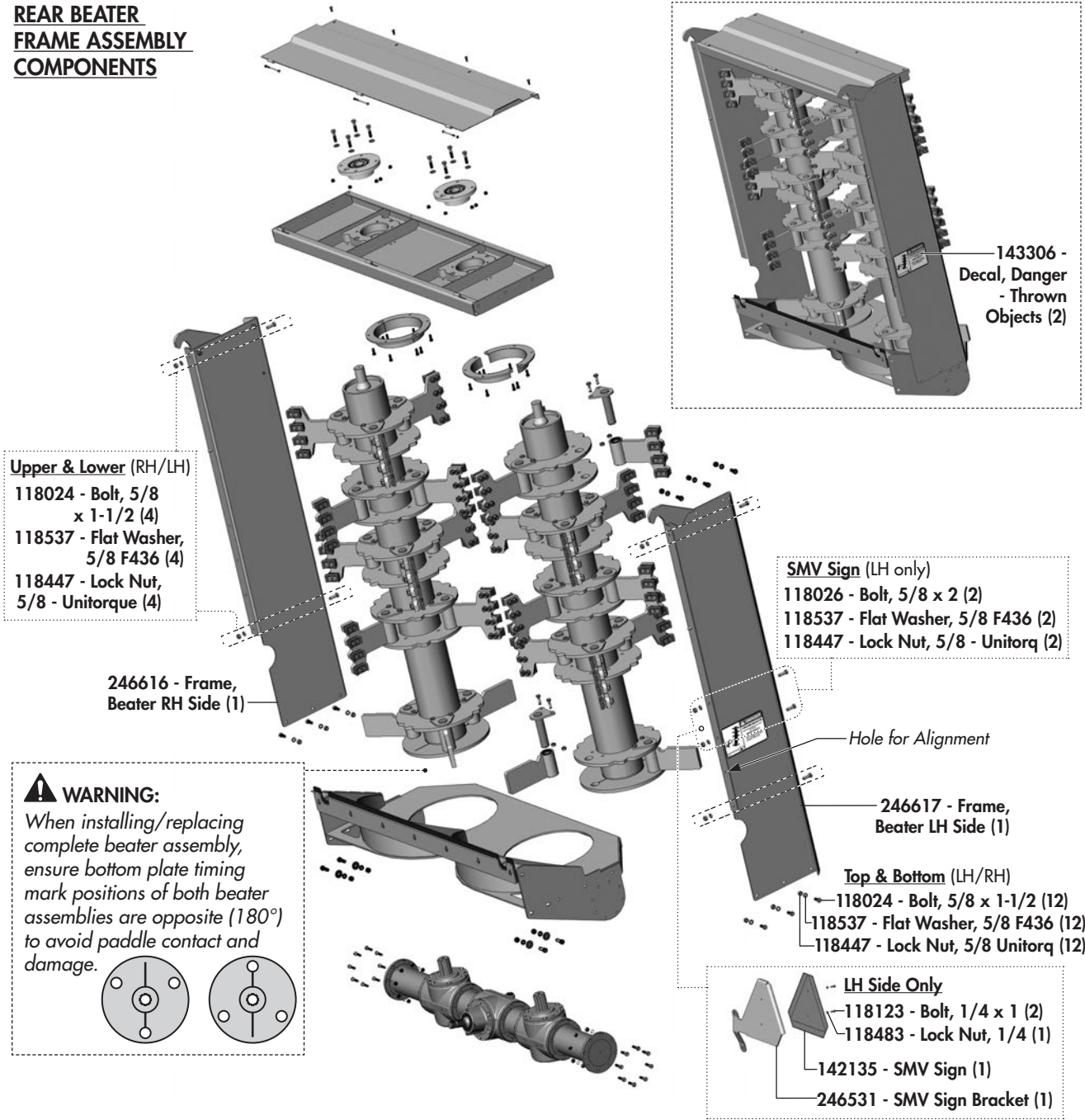

# Rear Frame & Beater Components

## TOP BEATER FRAME & BEARINGS

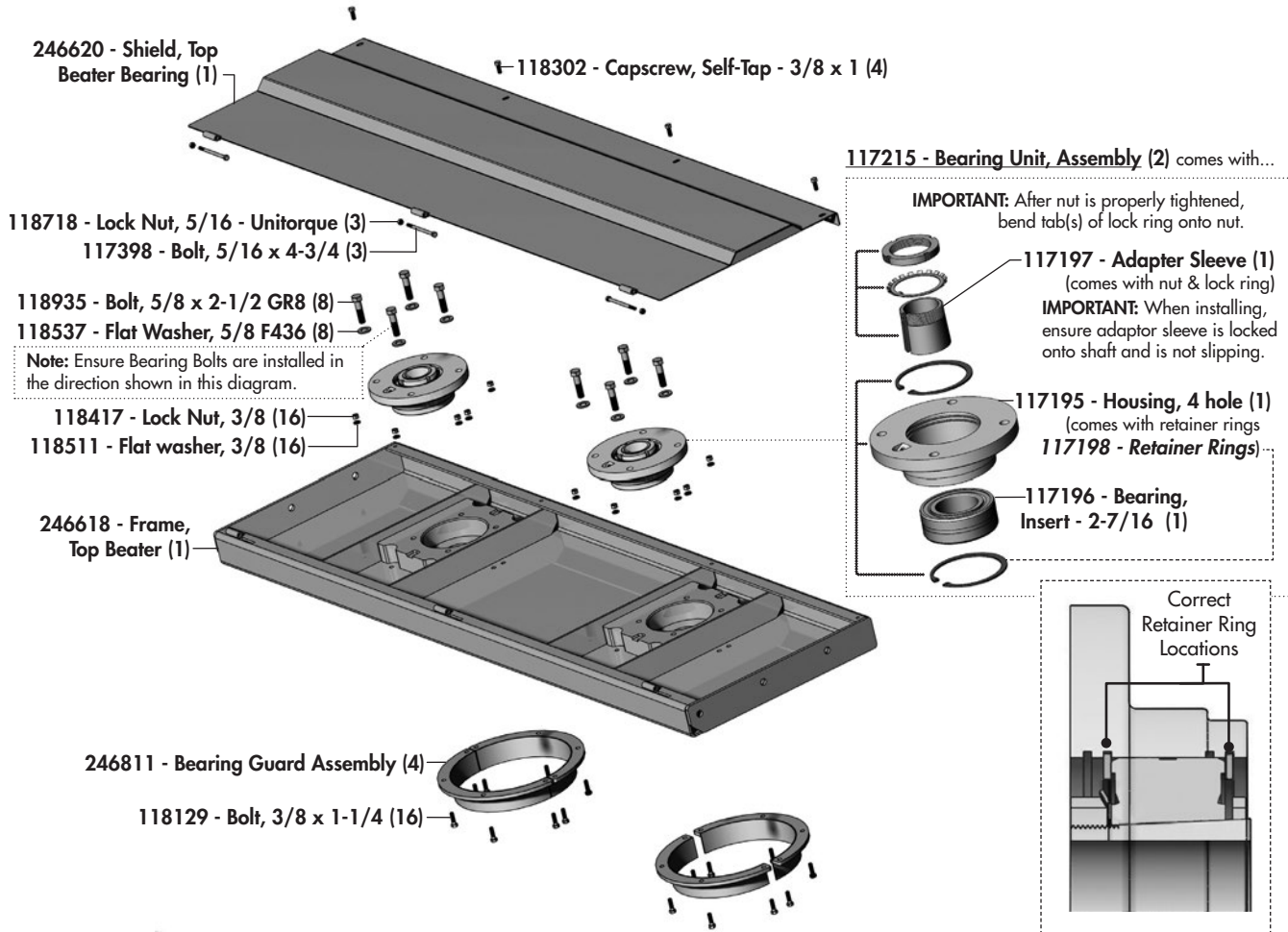

## LOWER BEATER FRAME AND GEARBOX

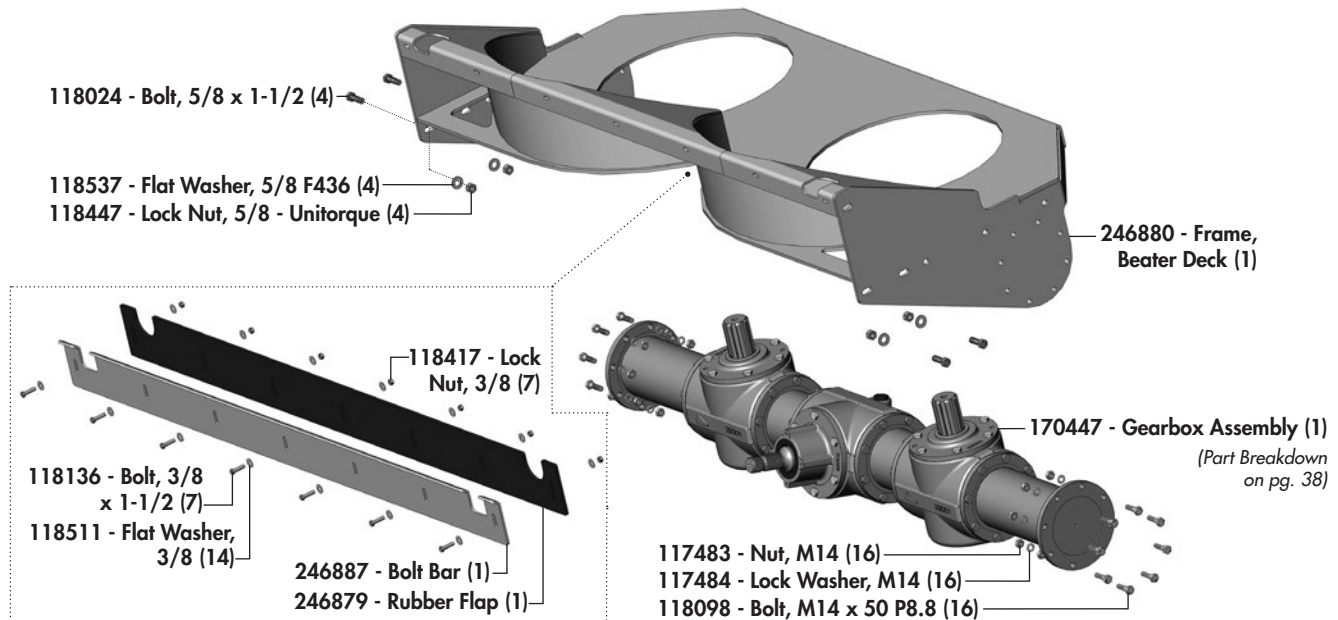



# Rear Beater Components

## BEATER CORE, PADDLE & PIN ASSEMBLIES

**NOTE:** It is recommended to replace *all three* paddles from a row at the same time to maintain proper balance of beater assembly.

**246656 - Beater Core Assembly - RH (1)**  
(with CT Paddles)

**246657 - Beater Core Assembly - LH (1)**  
(with CT Paddles)

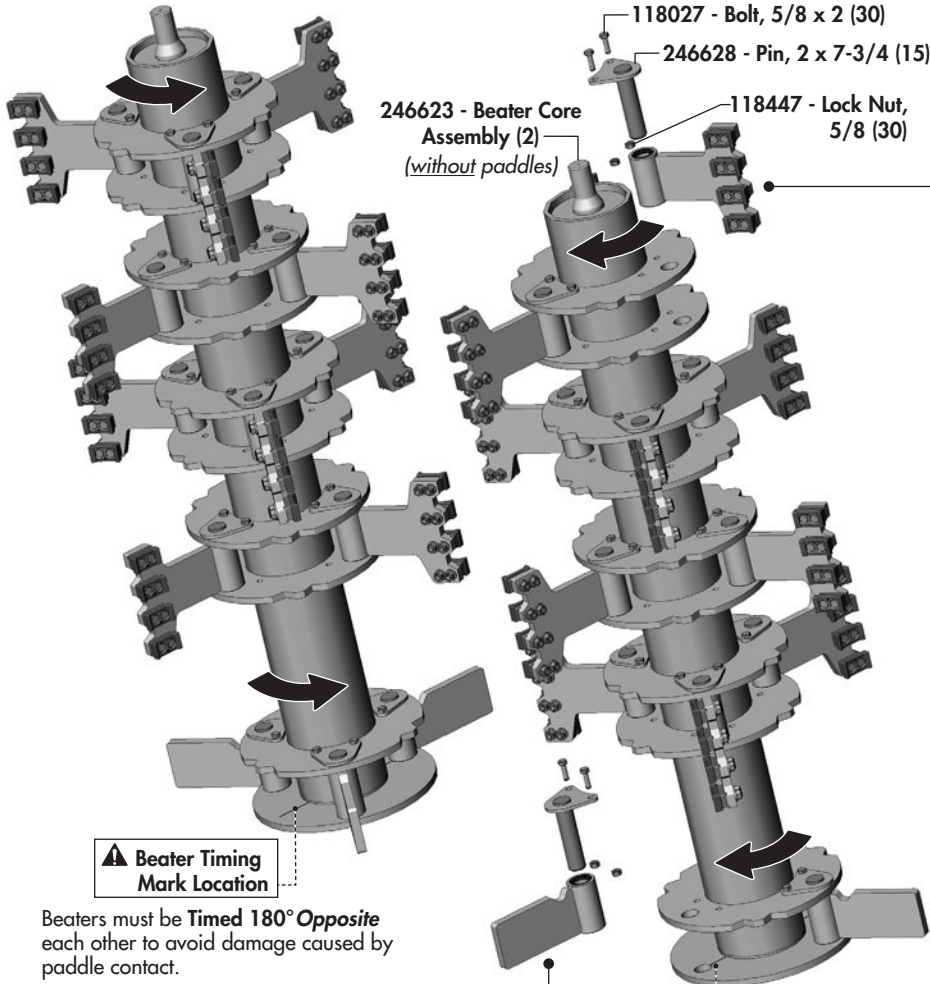

**Beater Timing Mark Location**

Beaters must be **Timed 180° Opposite** each other to avoid damage caused by paddle contact.

**WARNING:**

When installing/replacing complete beater assembly, ensure bottom plate timing mark positions of both beater assemblies are opposite (180°) to avoid paddle contact and damage.

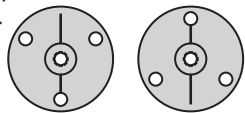

**246805 - Paddle, Bottom Row (3)**  
comes with:

**117179 - Bushing (1)**

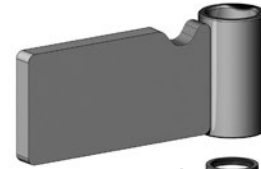

**246782 - Seal, Wiper - Dual Lip (2)**

**OPTIONAL COMPONENTS:**

**246825 - Hard Surfaced Paddle, Bottom Row (3)**  
comes with:

**117179 - Bushing (1)**

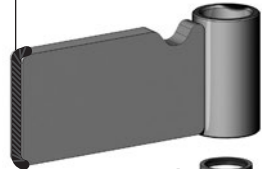

**246782 - Seal, Wiper - Dual Lip (2)**

**246691 - Carbide Tip Hammer Head Paddle Assembly (12)**

**246782 - Seal, Wiper - Dual Lip (2)**

**117179 - Bushing (1)**

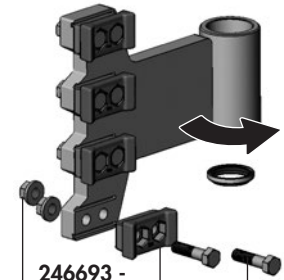

**246693 - Wear Tip (4)**

**117581 - Lock Nut, 5/8 Flanged (8)**

**118935 - Bolt, 5/8 x 2-1/2 GR8 (8)**

**NOTE:** Wear tip paddles **must** be installed with tips facing direction of rotation.

**OPTIONAL COMPONENTS:**

**246625 - Hammer Head Paddle Assembly (12)**

**246782 - Seal, Wiper - Dual Lip (2)**

**117179 - Bushing (1)**

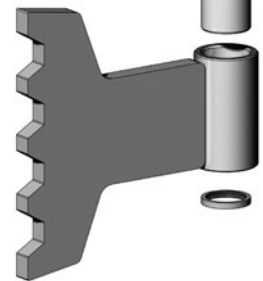

# Rear Beater Gearbox Components

## GEARBOX COMPONENTS

170447 - Complete Gearbox Assembly (1)

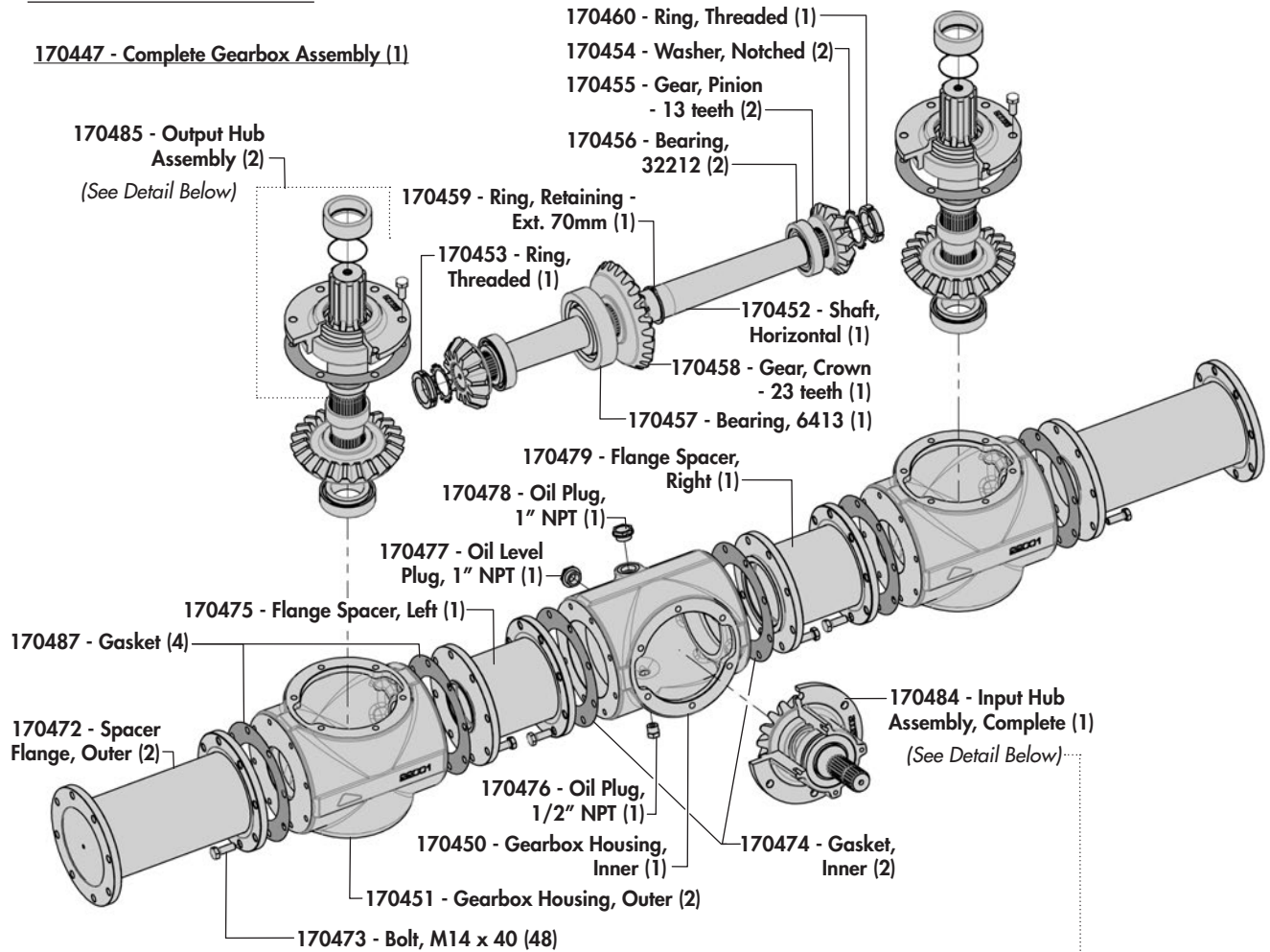

### 170485 - Output Hub Assembly (comes with)

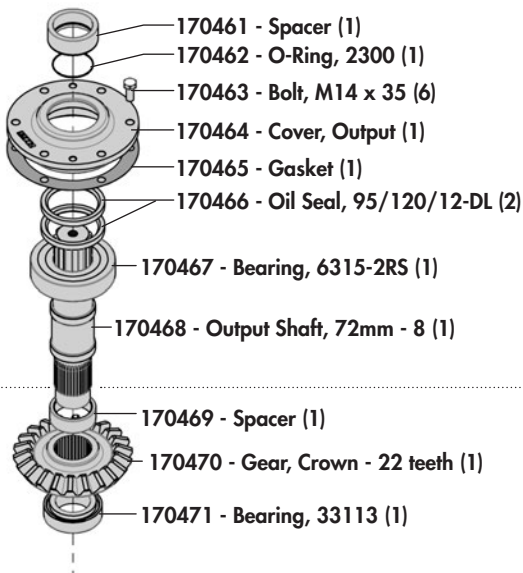

### 170484 - Input Hub Assembly, Complete

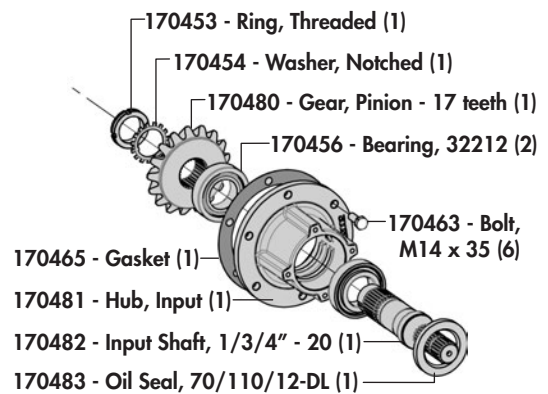

# Driveline Components

## DRIVELINE & MOUNTING COMPONENTS (Main Assembly)

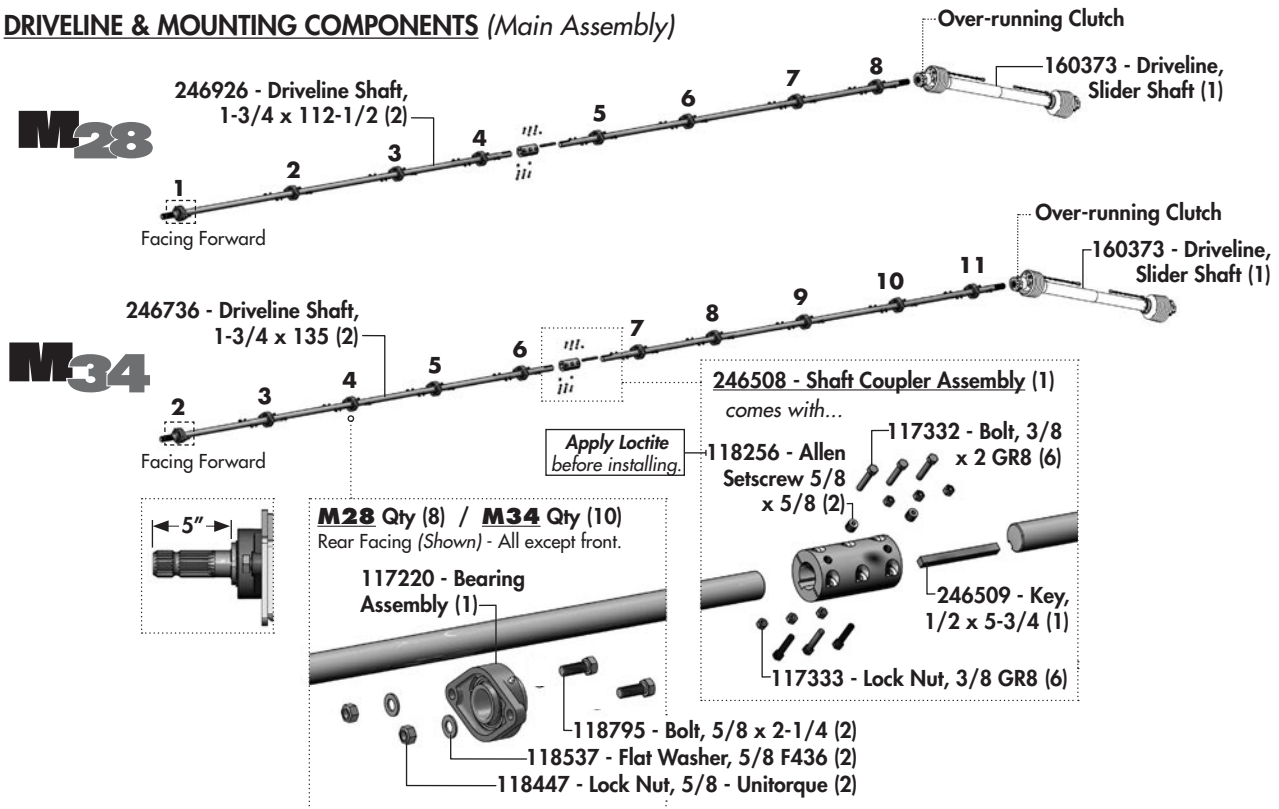

## DRIVELINE & MOUNTING COMPONENTS (Front Hitch)

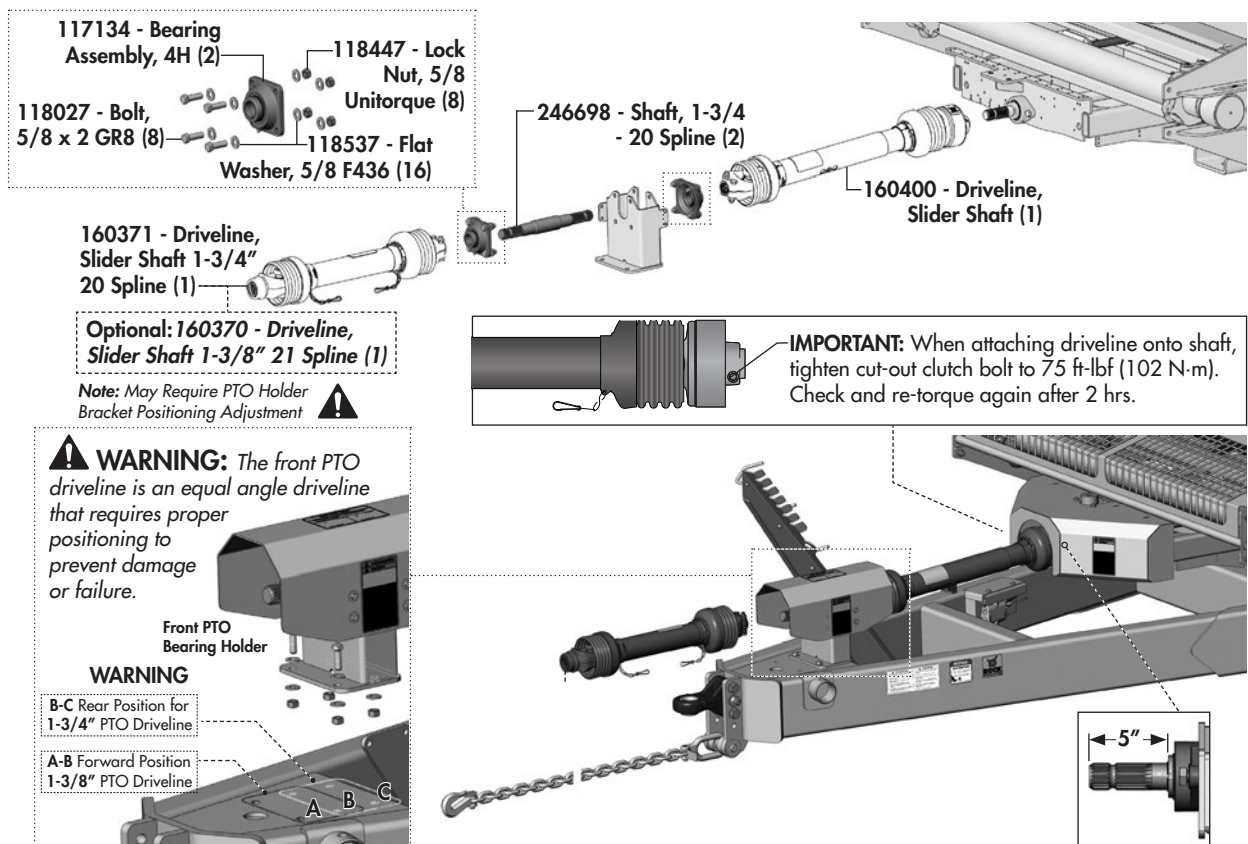

# Driveline Components

## 160371 - DRIVELINE SLIDER SHAFT, 26-36 - 1-3/4", 20-Spline

(Tractor to front shaft driveline)

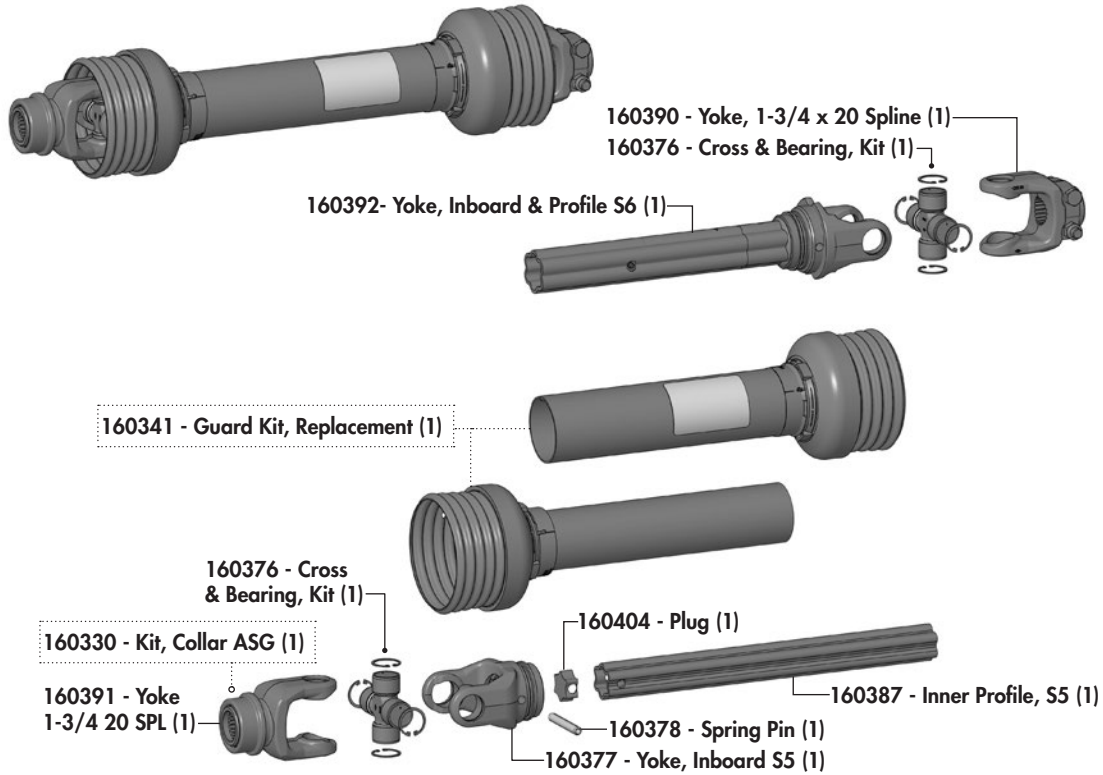

## \*\*OPTIONAL\*\* 160370 - DRIVELINE SLIDER SHAFT, 21-27 - 1-3/8", 21-Spline

(Tractor to front shaft driveline)

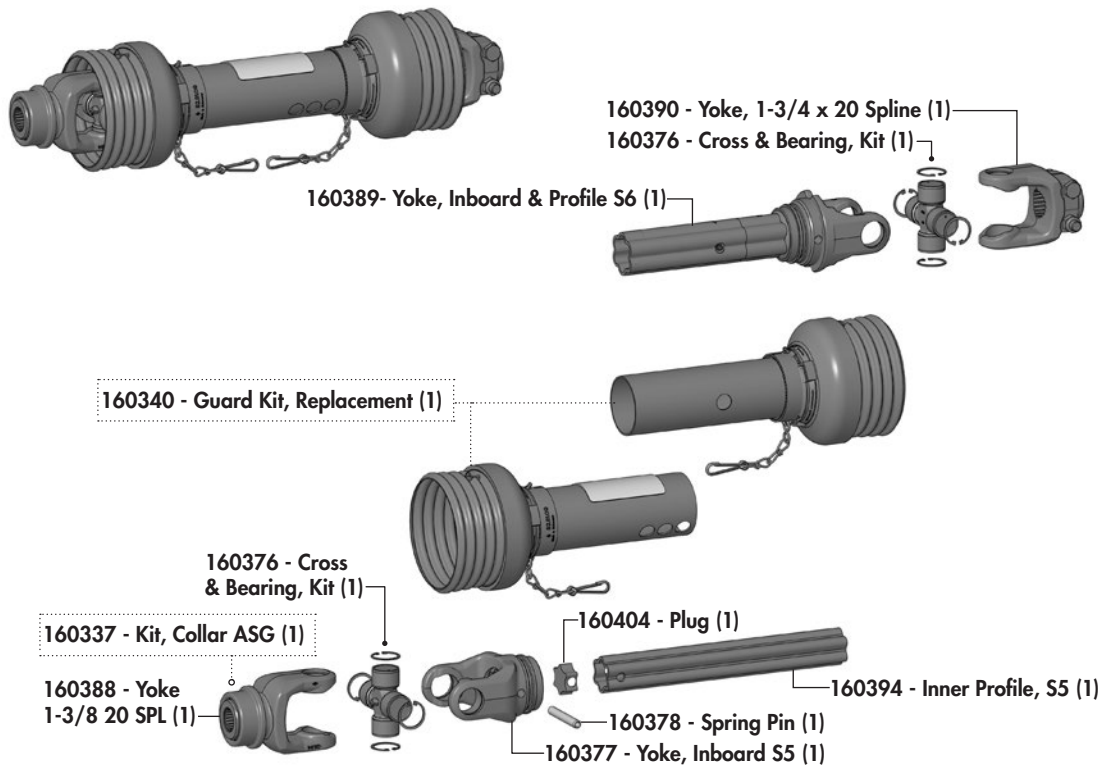

# Driveline Components

## 160400 - DRIVELINE SLIDER SHAFT, 32-43 - 1-3/4", 20-Spline

(Shaft driveline)

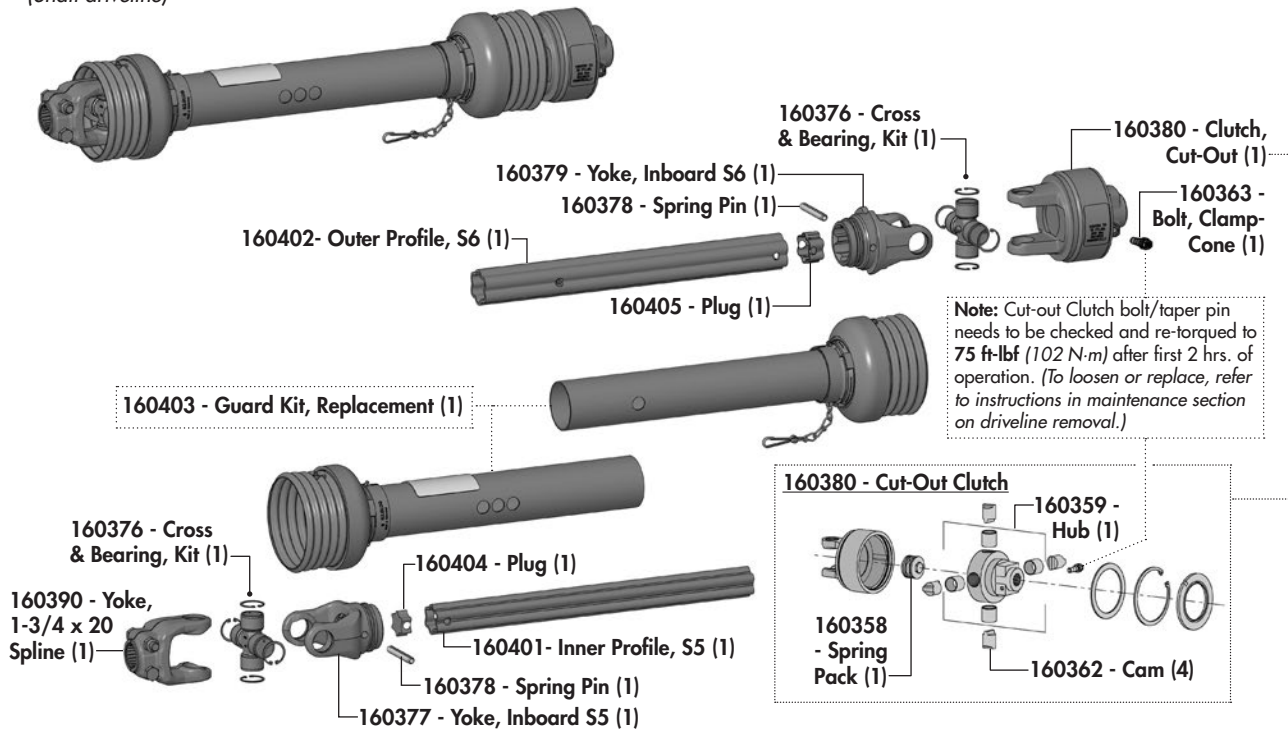

## 160373 - DRIVELINE SLIDER SHAFT, 38-52 - 1-3/4", 20-Spline

(Rear driveline to gearbox)

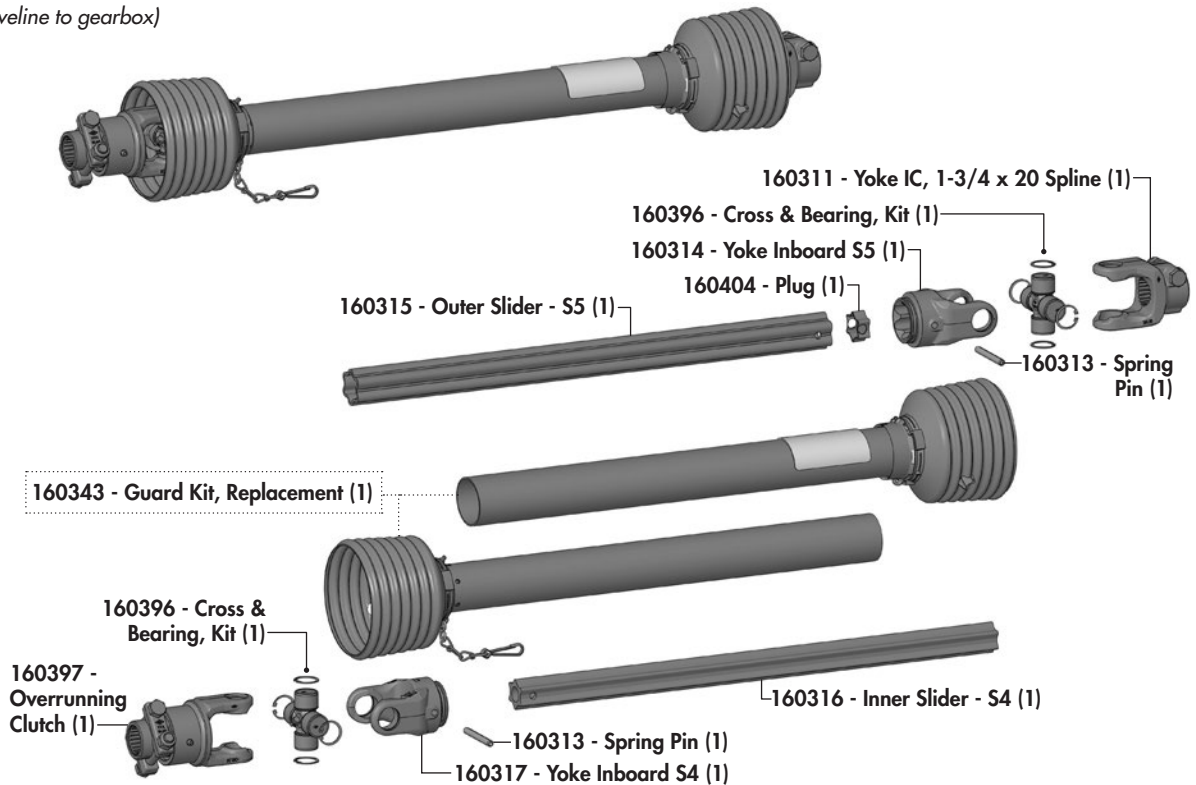

# Hydraulic Routing - Hose Clamps & Shields

## HOSE CLAMPS & SHIELDS

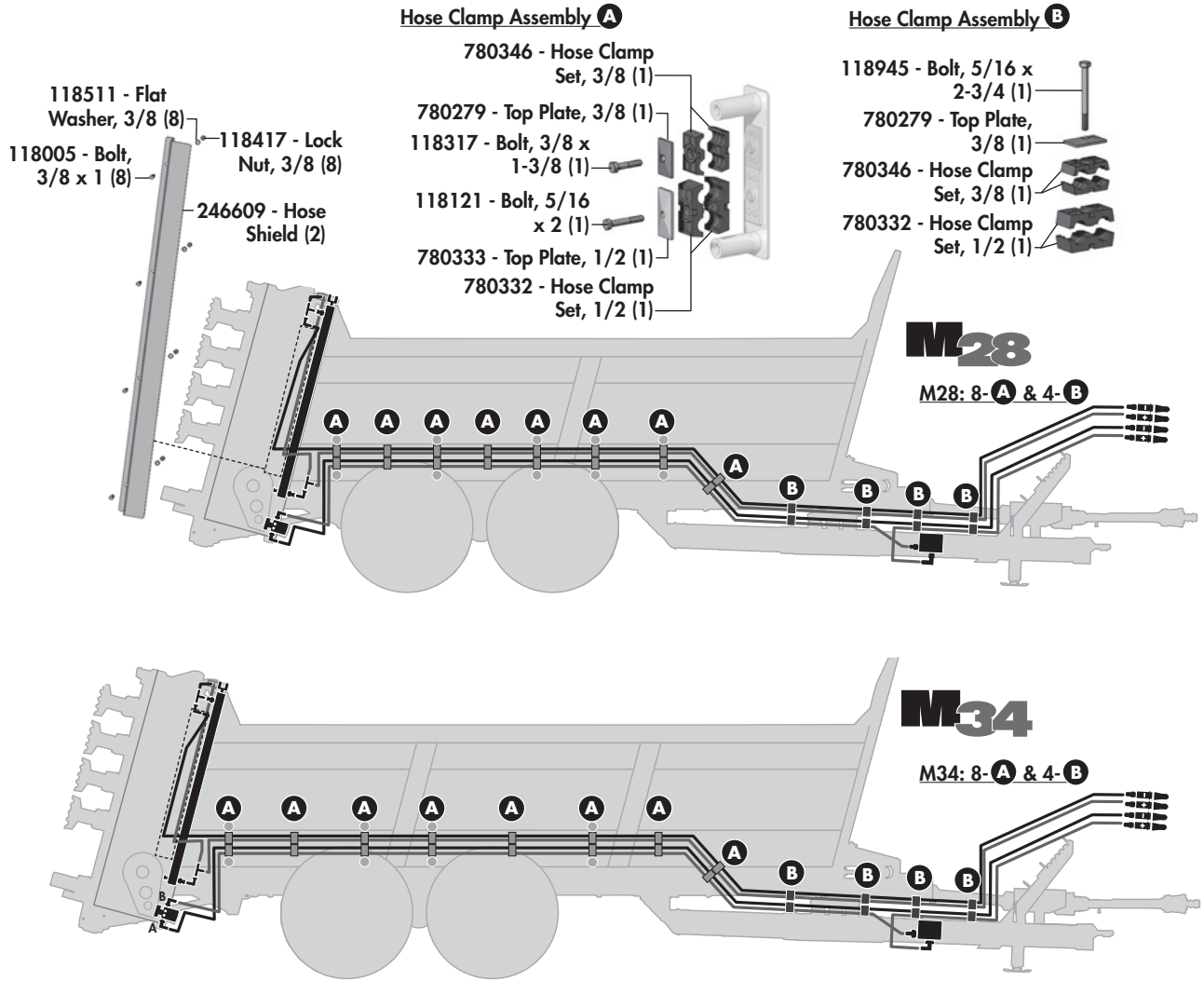

**Typical Shield Mounting Hardware**  
(as required)

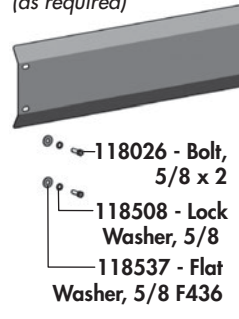

# Hydraulic Routing - Gate Cylinders

## HOSE ROUTING FOR REAR GATE CYLINDERS

### Required Hoses for Gate Cylinders

Hoses for M34 Only

- ⑤40 126655- Hose, 3/8 x 540 (1)
- ④66 126619- Hose, 3/8 x 466 (1)

Hoses for M28 Only

- ④92 126630- Hose, 3/8 x 492 (1)
- ④20 126663- Hose, 3/8 x 420 (1)

Hoses for both Models

- ②58 126080- Hose, 3/8 x 258 (1)
- ①04 126512- Hose, 3/8 x 104 (1)

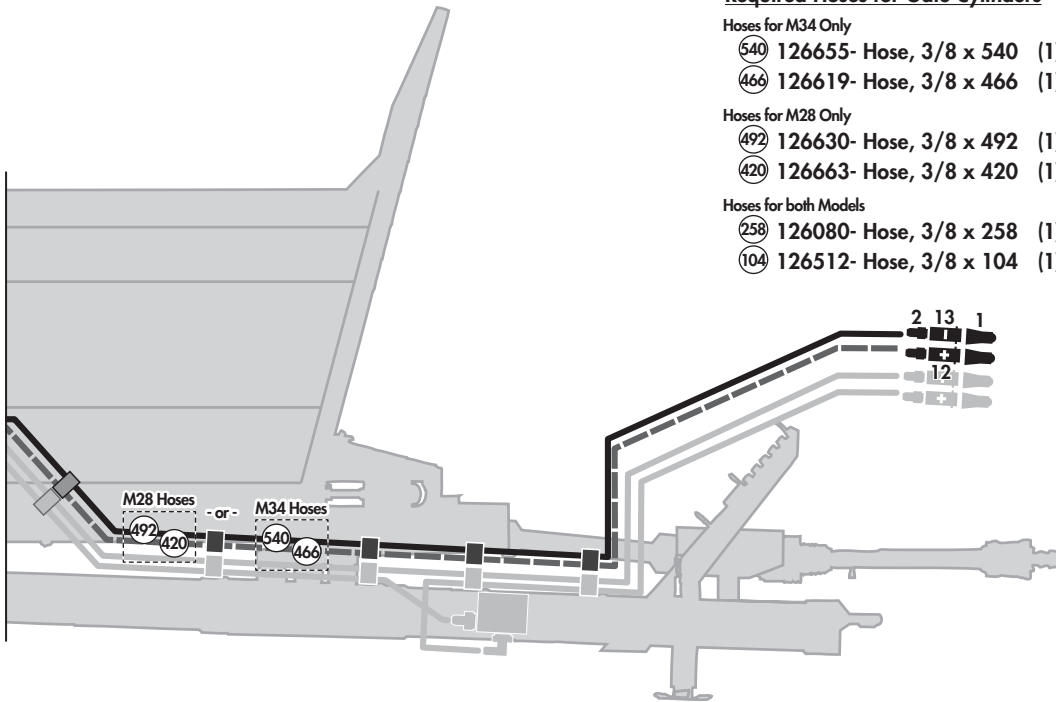

### Hydraulic Fittings Required

- |    |  |  |     |
|----|--|--|-----|
| 1  |  | 141581 - Quick Coupler-m - 3/4 ORB           | (2) |
| 2  |  | 141515 - Connector, 3/4 JIC-m x ORB          | (2) |
| 6  |  | 141518 - 90° Elbow, 3/4 JIC-m x 3/4 JIC-f-sw | (2) |
| 7  |  | 141501 - Tee, 3/4 JIC-m x m x m              | (2) |
| 8  |  | 141583 - Adaptor, 3/4 JIC-f-sw x 9/16 ORB    | (2) |
| 9  |  | 141613 - 45° Elbow, 3/4 JIC-m x 9/16 ORB     | (1) |
| 10 |  | 141560 - 90° Elbow, 3/4 JIC-m x 9/16 ORB     | (1) |
| 11 |  | 141633 - Plug, Port - 9/16 ORB               | (2) |
| 12 |  | 141832 - Grip, Blue +                        | (1) |
| 13 |  | 141833 - Grip, Blue -                        | (1) |

**Note:** Hoses run through top tube to second cylinder. Cylinder shown separated for illustration purposes only.

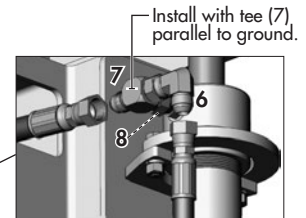

### Gate Cylinders:

123056 - Cylinder, 2 x 72 x 1-1/4 (2)

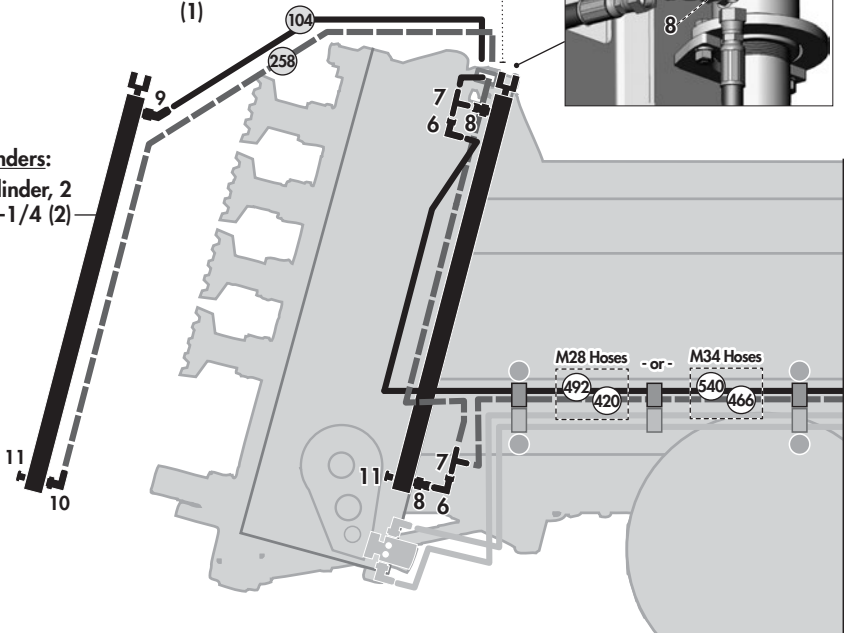

# Hydraulic Routing - Rear Hydraulic Motor

## HOSE ROUTING FOR REAR HYDRAULIC MOTOR

### Required Hoses for Hydraulic Motor

Hoses for M34 Only

- ④86 126686- Hose, 1/2 x 486 (1)
- ③54 126685- Hose, 1/2 x 354 (1)

Hoses for M28 Only

- ④38 126684- Hose, 1/2 x 438 (1)
- ③06 126097- Hose, 1/2 x 306 (1)

Hose for both Models

- ①69 126572- Hose, 1/2 x 169 (1)

Hoses for Dual Drive Option

- ②75 126560- Hose, 1/2 x 275 (2)

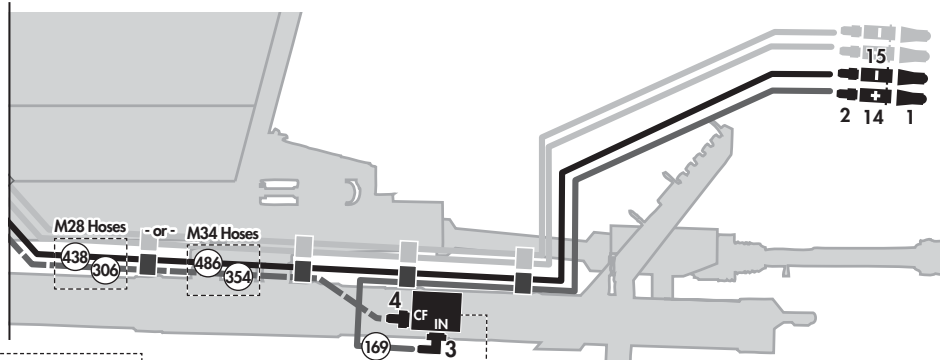

### Valve Hyd Connections

"CF" PORT - To "B" on Hyd Motor

"IN" PORT - From Tractor

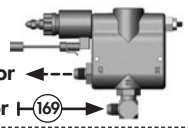

Note: Valve is located on inside of frame.  
141121 - Valve, EFC (1)

246515 - Valve Assembly (c/w Valve, Hyd Fittings, and Wiring) (1)

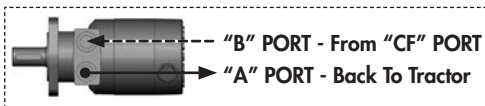

### Hydraulic Fittings Required

- 1 141581 - Quick Coupler-m - 3/4 ORB (2)
  - 2 141515 - Connector, 3/4 JIC-m x ORB (2)
  - 3 141617 - 90° Elbow, 3/4 JIC-m x 1-1/16 ORB (1)
  - 4 141618 - Adaptor, 3/4 JIC-m x 1-1/16 ORB (1)
  - 5 141541 - 90° Elbow, 3/4 JIC-m x 7/8 ORB (2)
  - 14 141830 - Grip, Green + (1)
  - 15 141831 - Grip, Green - (1)
- Extra fittings for Dual Drive Option*
- 5 141541 - 90° Elbow, 3/4 JIC-m x 7/8 ORB (2)
  - 16 141513 - 90° Elbow, 3/4 JIC-m x m (1)

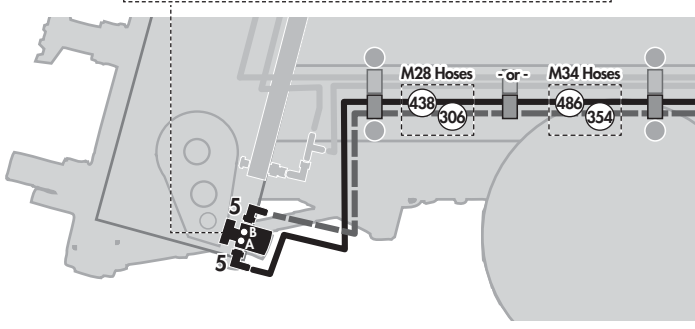

### OPTION: Rear Hydraulic Routing for Dual Drive

Note: Hoses run through top tube to LH side. Dual Drive Motor shown separated for illustration purposes only.

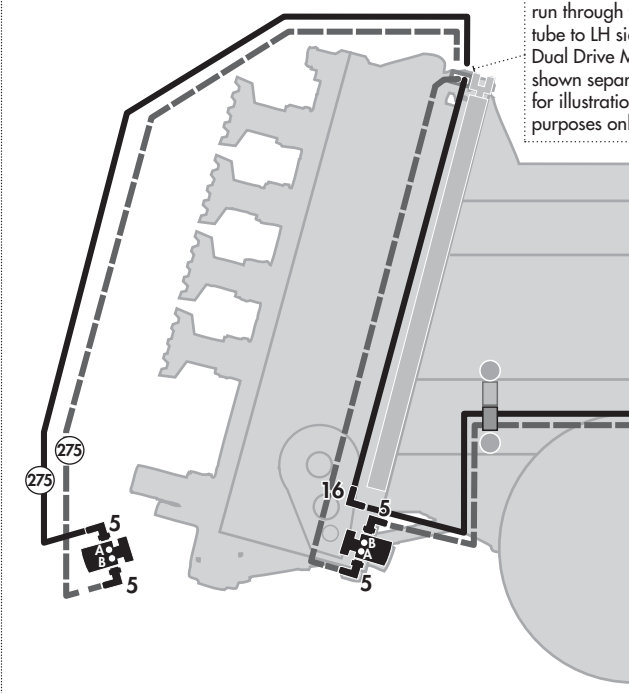

### For Dual Drive Option Only

#### Valve Hyd Connections

"CF" PORT - To "B" on Hyd Motor 1

"IN" PORT - From Tractor

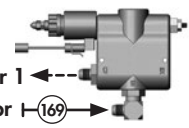

#### Motor 1

"B" PORT - From "CF" PORT  
"A" PORT - to Dual Drive "B"

#### Dual Drive Motor

"A" PORT - Back to Tractor  
"B" PORT - From Motor 1 "A"

### Extra fittings for Dual Drive Option

- 5 141541 - 90° Elbow, 3/4 JIC-m x 7/8 ORB (2)
- 16 141513 - 90° Elbow, 3/4 JIC-m x m (1)

### Hoses for Dual Drive Option

- ②75 126560- Hose, 1/2 x 275 (2)



# Electrical Components - Flow Control Valve

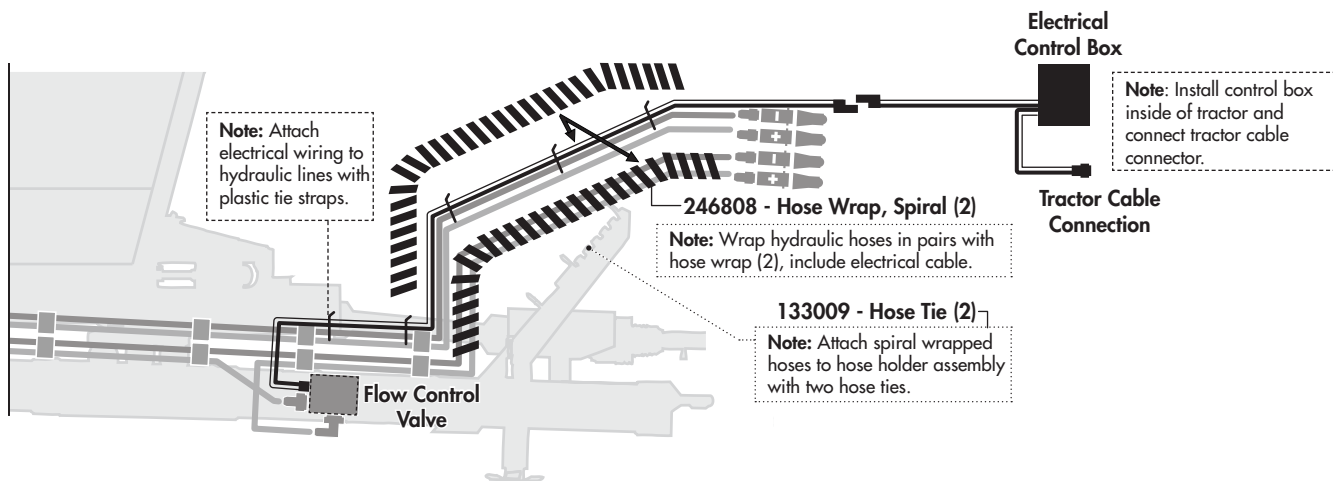

## 246514 - Flow Control Valve & Electrical Control Box Assembly (1) comes with...

### 246519 - Electrical Control Box & Wiring Cable Assembly (1)

comes with...

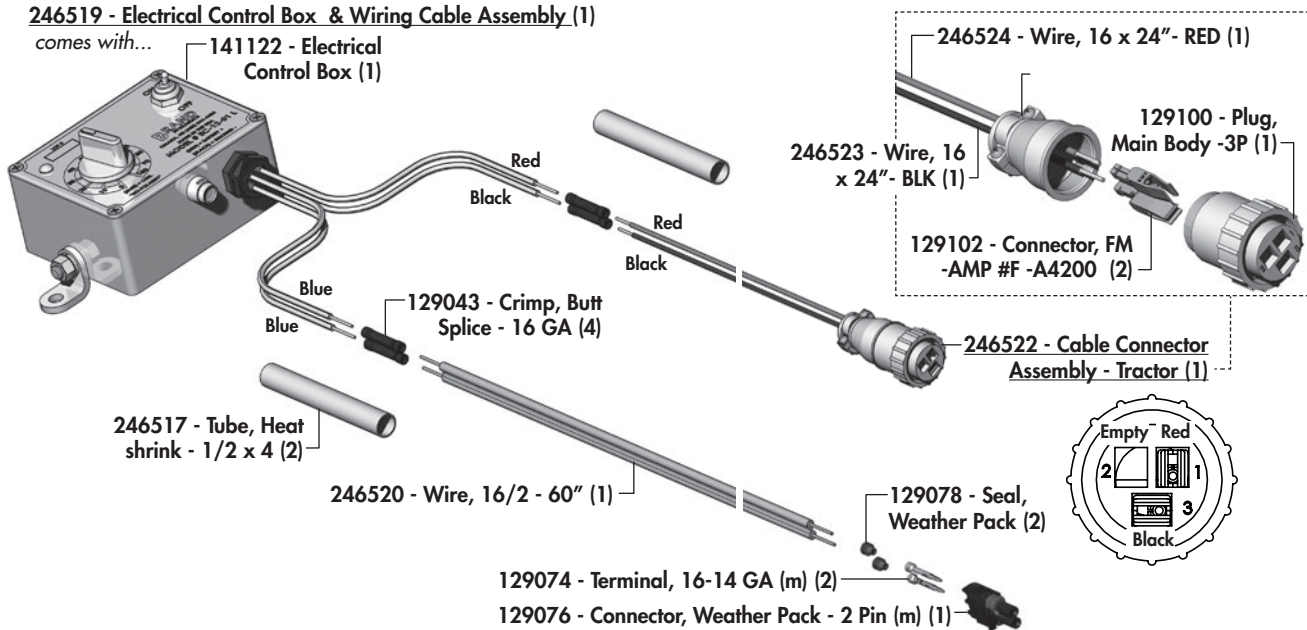

### 246515 - Flow Control & Wiring Assembly (1)

comes with...

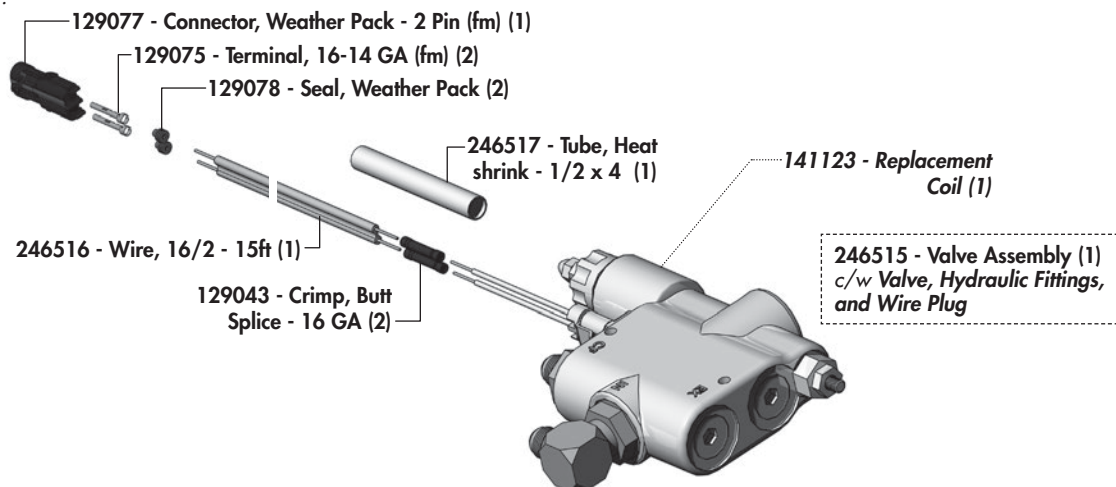

# Electrical Components - Lights

## LIGHT ROUTING & COMPONENTS

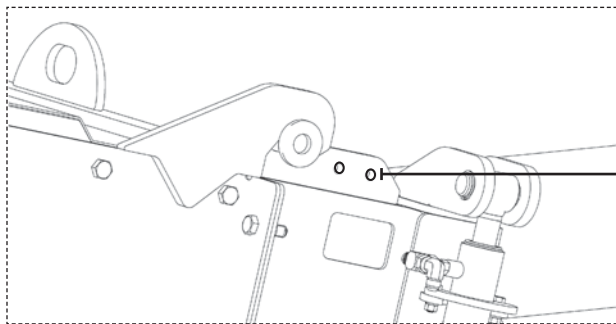
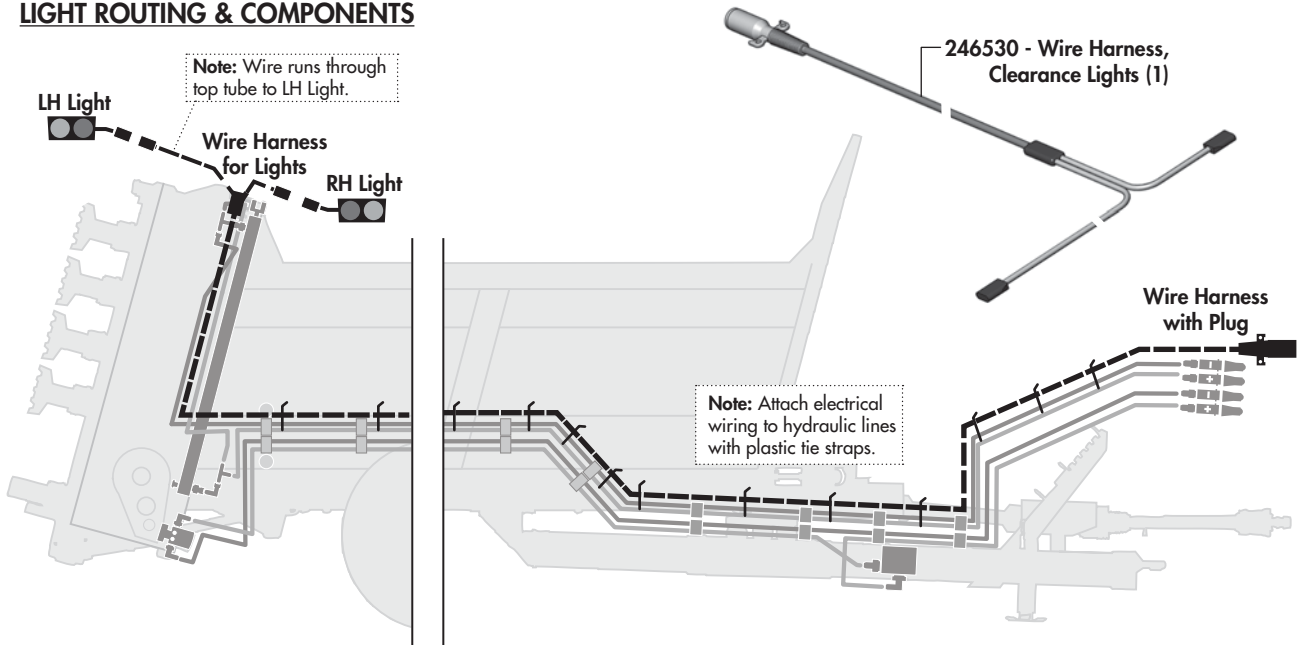

118756 - Bolt, 1/4 x 1-1/4 (4)

118587 - Flat Washer, 1/2 (2)

118729 - Lock Nut, 1/2  
Unitorque (2)

118011 - Bolt, 1/2 x 1-1/2 (2)

246532 - Light Bracket - RH (1)

246533 - Light Bracket - LH (1)

129125 - Lamp, Dual LED - RH (1)

129126 - Lamp, Dual LED - LH (1)

118555 - Flat Washer, 1/4 (4)

118483 - Lock Nut, 1/4 (4)

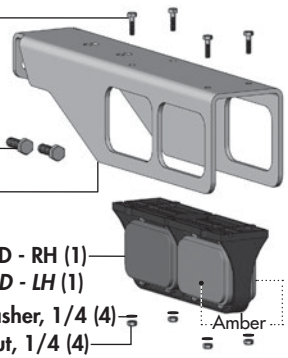
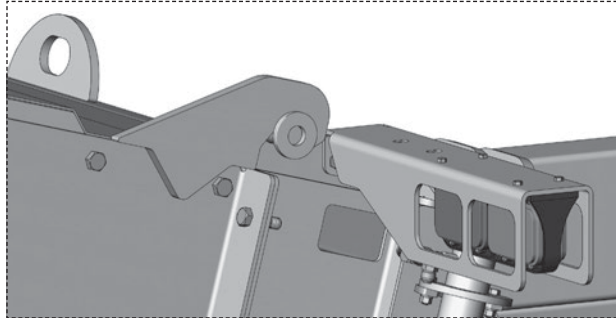

# Side Extensions *(Optional)*

## OPTIONAL SIDE EXTENSION KITS

**M34**  
 Optional - **249023 - Side Extension Bundle, M34 (1)**

**M28**  
 Optional - **249000 - Side Extension Bundle, M28 (1)**  
 (Shown installed)

Both kits include ladder mount extension components.

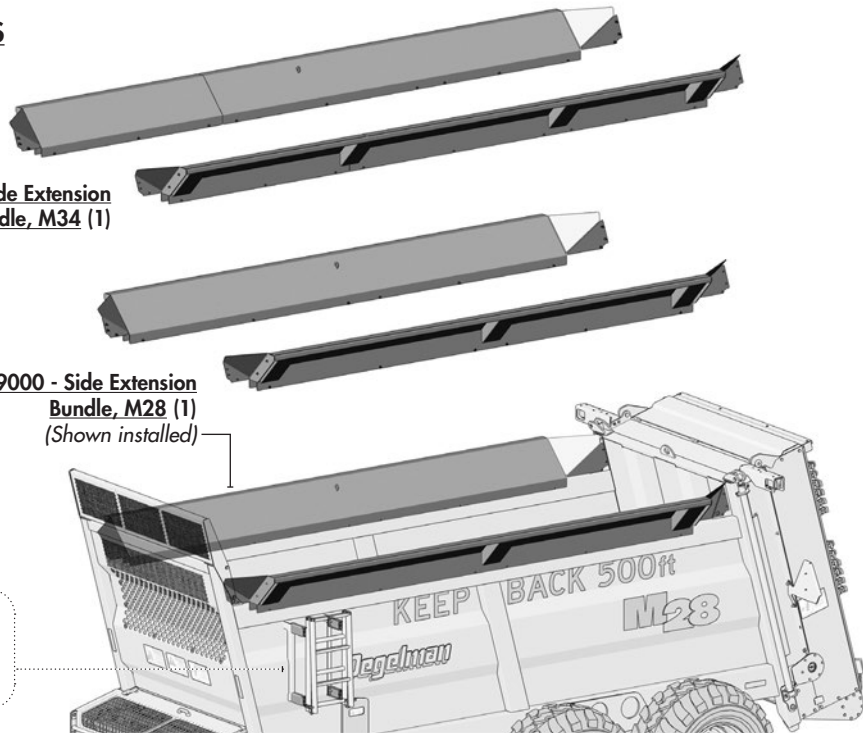
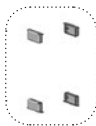

## SIDE EXTENSION COMPONENTS

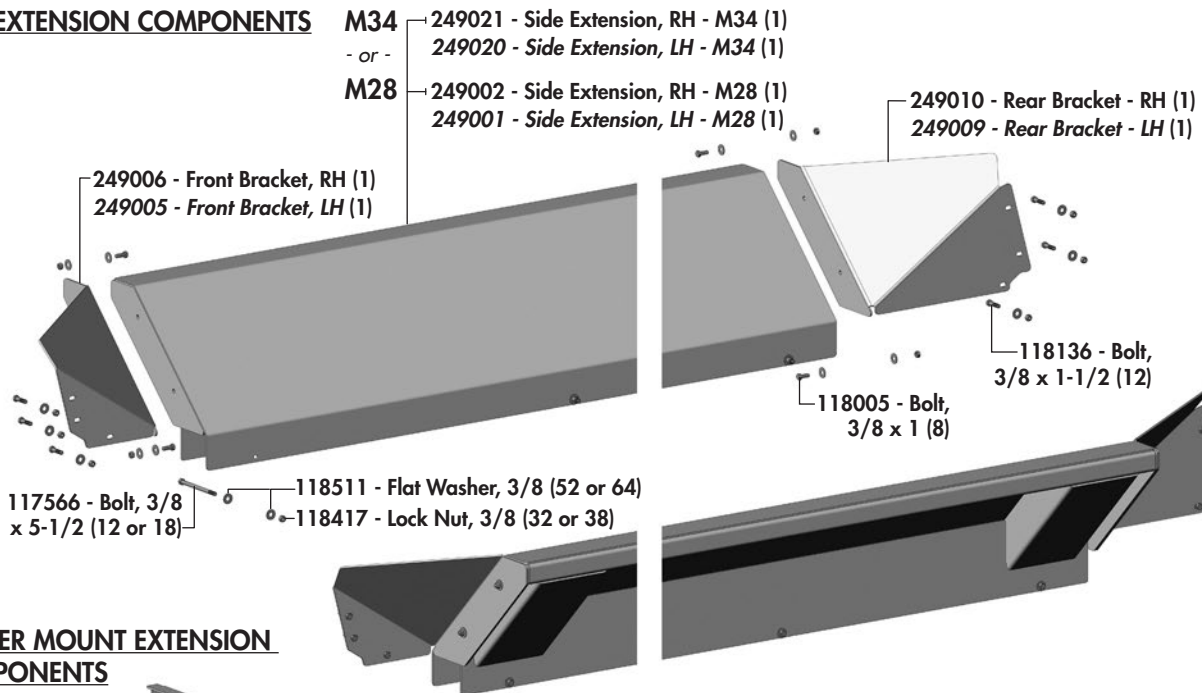

## LADDER MOUNT EXTENSION COMPONENTS

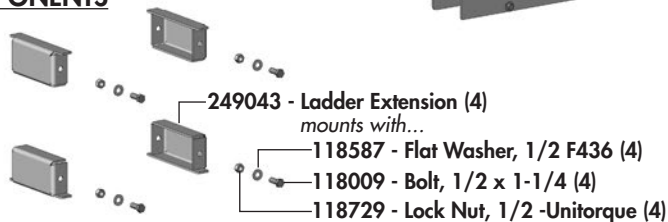

# Skid Plate Kits (Optional)

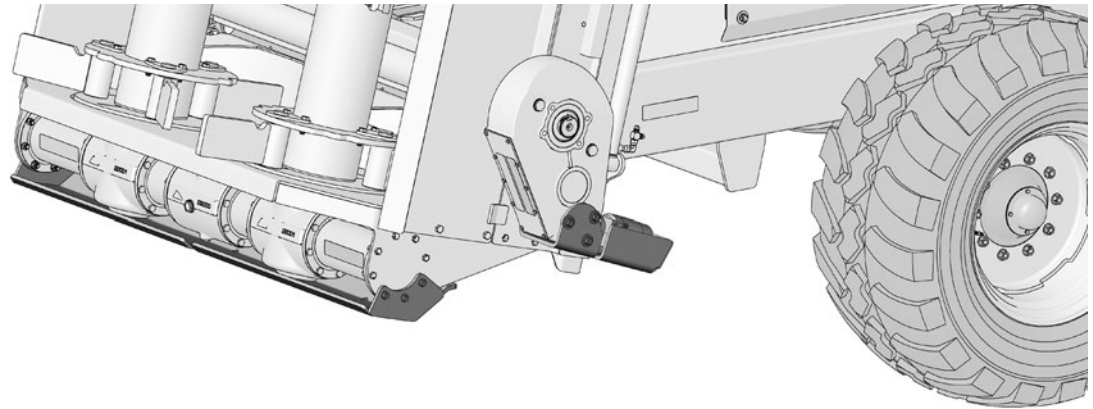

## Optional - GEARBOX & MOTOR SKID PLATE KIT (Single Drive)

### 247991 - Single Drive Kit (1)

117972 - Bolt,  
M14 x 70 (6)

117974 - Flat  
Washer, M14 (12)

117973 - Lock  
Nut, M14 (6)

118760 - Flat  
Washer, M16 (12)

117995 - Lock  
Washer, M16 (12)

118099 - Bolt,  
M16 x 50 (3)

118148 - Bolt,  
M16 x 40 (3)

247992 - Gearbox Skid  
Plate Assembly (1)

247996 - Motor  
Skid Plate - RH (1)

## Optional - GEARBOX & MOTOR SKID PLATE KIT (Dual Drive)

### 247990 - Dual Drive Kit (1)

118148 - Bolt,  
M16 x 40 (3)

118099 - Bolt,  
M16 x 50 (3)

117972 - Bolt,  
M14 x 70 (6)

117974 - Flat  
Washer, M14 (12)

117973 - Lock  
Nut, M14 (6)

247997 - Motor  
Skid Plate - LH (1)

118760 - Flat  
Washer, M16 (12)

117995 - Lock  
Washer, M16 (12)

118099 - Bolt,  
M16 x 50 (3)

118148 - Bolt,  
M16 x 40 (3)

247992 - Gearbox Skid  
Plate Assembly (1)

247996 - Motor  
Skid Plate - RH (1)

# Warranty

---

## **2 Year** **Limited Warranty - Agricultural Products**

Degelman Industries LP ("Degelman") warrants to the original purchaser of any new Degelman equipment, purchased from an authorized Degelman dealer, that the equipment will be free from defects in material and workmanship for a period of two (2) years from the date of delivery, for non-commercial use (including farm, institutional, government, and municipality) and (1) year from the date of delivery for commercial use. The obligation of Degelman to the purchaser under this warranty is limited to the repair or replacement of defective parts in the first year and to the provision, but not the installation of replacement parts in the second year. Degelman reserves the right to inspect any equipment or parts which are claimed to have been defective in material or workmanship.

This warranty limits its replacement or repair coverage to what is consistent with the warranty of Degelman's suppliers of purchased components.

Replacement or repair parts installed in the equipment covered by this limited warranty are warranted for ninety (90) days from the date of delivery of such part or the expiration of the applicable new equipment warranty period, whichever occurs later. Warranted parts shall be provided at no cost to the user at an authorized Degelman dealer during regular working hours. Warranted replacement parts will either be replaced or rebuilt at Degelman's discretion.

### ***Disclaimer of implied warranties & consequential damages***

This warranty shall not be interpreted to render Degelman Industries LP liable for injury, death, property damage or damages of any kind, whether direct, consequential, or contingent to property. Without limiting the generality of the foregoing, Degelman shall not be liable for damages resulting from any cause beyond its reasonable control, including, without limitation, loss of crops, any expense or loss of labour, supplies, rental machinery or loss of use.

No other warranty of any kind whatsoever, express or implied is made with respect to this sale; and all implied warranties of merchantability and fitness for a particular purpose which exceed the obligations set forth in this written warranty are hereby disclaimed and excluded from this sale. This exclusion shall not apply in any jurisdiction where it is not permitted by law.

### ***This limited warranty shall not apply:***

1. If, in the sole opinion of Degelman, the unit has been subjected to misapplication, abuse, misuse, negligence accident or incorrect off-site machine set-up.
2. To any goods that have sustained damage or deterioration attributable to a lack of routine maintenance (eg. Check and Re-torque of fastening hardware, Hydraulic fluid purities, drive train alignments, and clutch operation)
3. If parts not made or supplied by Degelman have been used in the connection with the unit, if, in the sole judgement of Degelman such use affects its performance, safety, stability or reliability.
4. If the unit has been altered or repaired outside of an authorized Degelman dealership in a manner which, in the sole judgement of Degelman, affects its performance, safety, stability or reliability.
5. To expendable or wear items such as (eg. Harrow tines, Rock Picker and Rock Rake wear teeth and replaceable bushings and pins.) and any other items that in the company's sole judgement are a wear item.

No employee or representative of Degelman Industries LP is authorized to change this limited warranty in any way or grant any other warranty unless such change is made in writing and signed by the Degelman Service Manager.

This limited warranty is subject to any future availability of supply, which may directly affect Degelman's ability to obtain materials or manufacture replacement parts.

Degelman reserves the right to make improvements in design or changes in specifications at any time, without incurring obligations to owners of equipment previously delivered.

This limited warranty is subject to compliance by the customer to the enclosed *Retail Customer's Responsibility Under Degelman Warranty*.

# Warranty

## ***Retail Customer's Responsibility Under Degelman Warranty.***

It is the retail customer and/or Operator's responsibility to read the Operator's Manual, to operate, lubricate, maintain and store the equipment in accordance with all instructions and safety procedures. Failure of the operator to read the operators manual is a misuse of this equipment.

It is the retail customer and/or operators responsibility to inspect the product and to have any part(s) repaired or replaced when continued operation would cause damage or excessive wear to other parts or cause safety hazard.

It is the retail customer's responsibility to deliver the product to the authorized Degelman dealer, from whom he purchased it, for service or replacement of defective parts, which are covered by warranty. Repairs to be submitted for warranty consideration must be made within forty-five days of failure.

It is the Retail Customer's responsibility for any cost incurred by the dealer for hauling of the product for the purpose of performing a warranty obligation or inspection.

## **WARRANTY INFORMATION**

**Make certain the warranty registration card has been forwarded to:**

**Degelman Industries LP  
Box 830 -272 Industrial Dr.  
Regina, SK, Canada  
S4P 3B1**

Always give your dealer the serial number of your Degelman product when ordering parts or requesting service or other information.

The serial number is located on the machine as shown in the diagram below. In the space provided record the model number, the serial number and the date of purchase to assist your dealer in providing you with prompt and efficient service.

SERIAL NUMBER: \_\_\_\_\_

MODEL NUMBER: \_\_\_\_\_

DATE OF PURCHASE: \_\_\_\_\_

