

QUICK-START GUIDE*

for ROCK KING Rock Pickers

* Refer to operators manual for complete safety and operation info.



A Hook-up to Rock Picker

NOTE: Stop the tractor engine, place all controls in neutral, set park brake before dismounting.

1. Connect and properly secure to tractor drawbar.

1 HYDRAULIC GRILLE/DUMP...Grille/Dump Cylinders

2. Connect the Hydraulics. **2 SWING POLE CIRCUIT.....Swing Pole Cylinder**

3 HYDRAULIC REEL CIRCUIT.....Hydraulic Motor

3. Remove and place hitch jack into storage position.

Connect the Hyd lines

- Clean off couplers on hose & tractor with cloth
- Remove plugs & insert couplers
- Ensure pressure & return lines are matched up on same valve bank

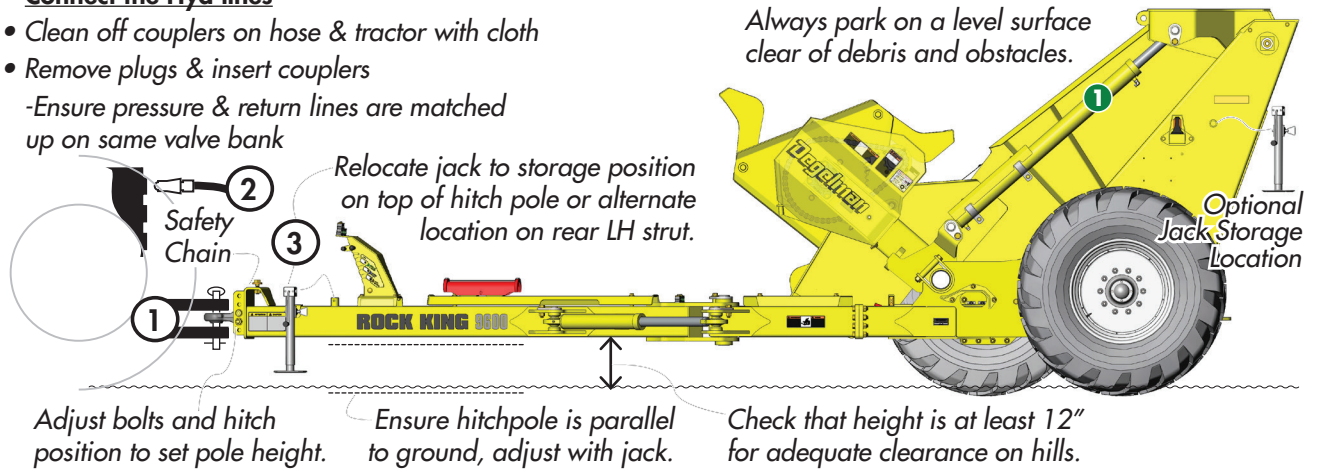

B Preparing the Rock Picker

1. Position Hitch Pole into Field Position.

- Remove and store the swing pole cylinder transport lock.
- Retract the swing pole cylinder **2** to its closed "field" position.

2. Grille Preparation.

- Fully retract the grille/dump cylinders **1** to take the weight of the grille off the red transport pin.
- Disengage the red transport lock pin from its transport position and secure it into field position.

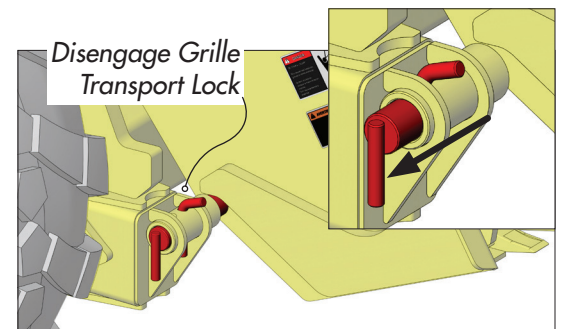
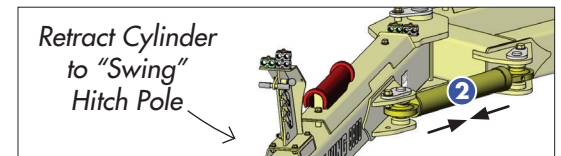
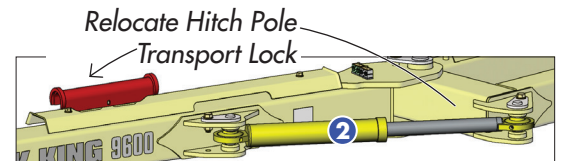

Maintenance

(Check Machine Daily)

* Refer to operators manual for complete safety & operation info.

- Check for missing, worn or damaged parts.
- Working points & pins
- Oil chain & check tension (approx 1/4")
- Hydraulic Connections & Hoses
- Tires, Hubs & Spindles

C Operation Overview

(Refer to operators manual for complete safety and operation info before use.)

- 1. Material Size:** Between 2-3/4" to 28" material that is loose and on top of the ground.
- 2. Grille Height:** Lower to allow the front of the teeth to skim the ground surface.
- 3. Ground Speed:** 4 to 6 MPH (6 to 10 km/h) is a normal operating speed. Reduce travel speed when picking heavy rock windrows.



- 4. Reel Speed:** The reel speed is controlled by the hydraulic flow rate .
For *Spot Picking*, run about 5% to 40% faster than ground speed.
For *Windrow Picking*, reduce forward speed when there are large numbers to control the number of rocks entering the machine.

⚠ IMPORTANT: Do not use the grille to pry out deeply buried rock or debris. Grille teeth striking a buried rock will shock the machine and damage it.

- 5. Loading:** Can be loaded until the hopper box is filled and rocks stay on the back edge of the grille. Do not overfill the box as to overflow onto the grille. When hopper box is full, stop the reel to prevent throwing rocks.

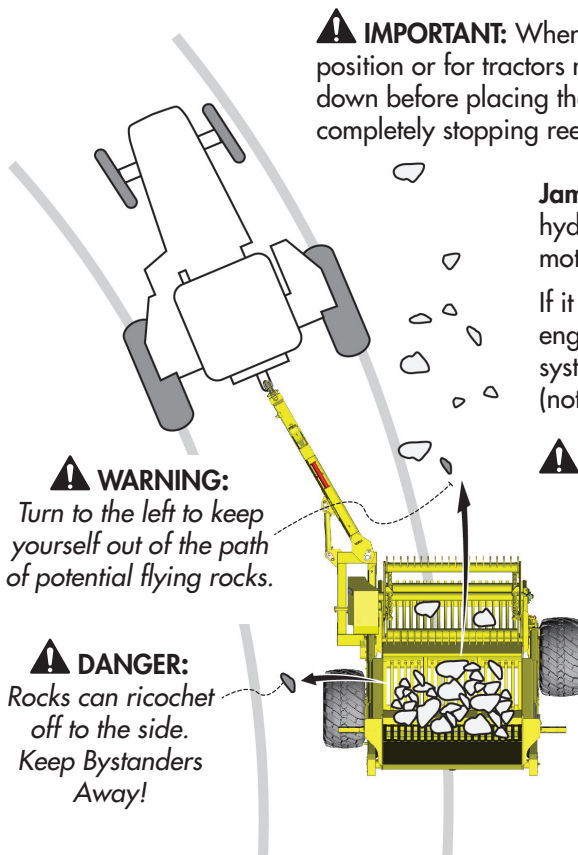

⚠ IMPORTANT: When stopping reel always place the tractor hydraulic lever into float position or for tractors not equipped with float position be sure to idle tractor speed down before placing the hydraulics into neutral. **Never** reverse reel direction without first completely stopping reel. Failure to do this will result in costly hydraulic motor damage.

Jamming/Unplugging: After reel has completely stopped, move the hydraulic control lever the other direction to reverse the hydraulic motor. Reversing the reel will in most cases dislodge the jammed rock.

If it does not unplug the machine, lower grille to ground, stop tractor engine, place all controls in neutral, relieve the pressure in hydraulic system, set park brake, remove ignition key, then use a long pry bar (not hands) to dislodge the material.

⚠ WARNING:
Turn to the left to keep yourself out of the path of potential flying rocks.

⚠ WARNING: Never use hands. Never get your head or arms into the machine. Stay clear of the paddle when removing any lodged material. The paddles could kick back from hydraulic pressure or spring tension. Always use a long bar to remove object.

⚠ DANGER:
Rocks can ricochet off to the side. Keep Bystanders Away!

⚠ DANGER: There is a danger that the paddle will catch the rocks and throw them forward if the reel speed is too fast.

- 6. Dumping:** The hopper box is unloaded by extending the unloading cylinders  on the box.

- When backing up with a full load, switch the hitch pole back to the transport position. This will prevent damage to the frame.
- Be sure the machine is on level ground when raising the hopper box to unload.
- Ensure there are no obstructions below the grille/grate area or the side cylinder lift bracket area when dumping.

⚠ WARNING
Ensure no obstructions under grill or near lift bracket areas.

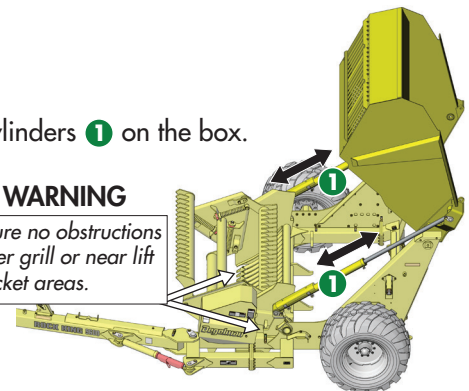

⚠ WARNING: Stay clear of the machine and surrounding area when unloading. Keep others away.