

6000/7200 Rockpicker - Hydraulic Swing Pole Conversion Kit

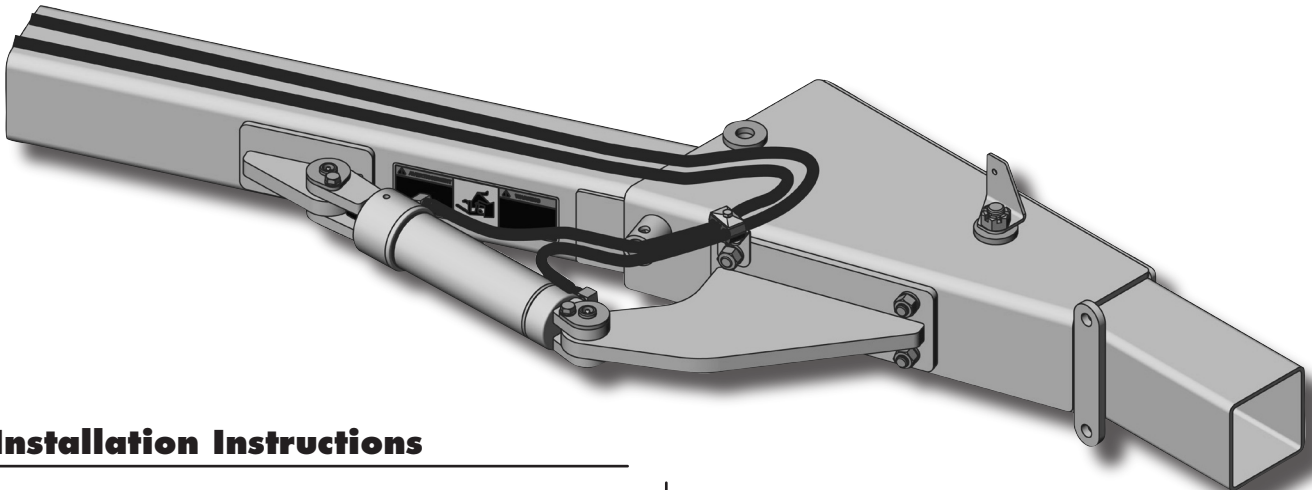

Installation Instructions

1. Temporarily mount Bolt-on bracket to the existing two holes in the pole holder plate; then, using the bracket bolt plate as a template, center, punch and drill two 13/16 in. diameter holes.
2. Permanently secure the bracket to frame using four 3/4 x 2 in. bolts.

⚠ IMPORTANT:

Be sure to install the bolts with the heads on the inside of pole holder. Also at this time, install the hose holder clip to the upper left bolt hole.

3. Assemble base end of hydraulic cylinder to Bolt-on bracket and attach the Weld-on lug to rod end.
4. Swing Hitch Pole fully outward until it makes contact with Pole Holder plate. Then swing Weld-on lug up against pole and mark out location of base plate. Grind this area clean.
5. Reposition lug assembly again and tack weld base plate to hitch pole. Be sure to protect cylinder rod from weld spatter. Proceed to swing pole over to check operation and then temporarily disconnect rod side of cylinder and swing away to allow for solid welding of base plate. Re-pin hydraulic cylinder.
6. Install elbow fittings into cylinder and route hoses along pole and secure through hose clamp halves and a 5/16 x 2 in. bolt, lockwasher and nut. Be sure to form a loop and recheck hose movement by swinging pole. Add remaining fittings to front end of hoses as shown.
7. Touch-up exposed welded area with spray paint provided and install the new safety decals.

