

QUICK-START GUIDE*

for **HDSR 930-1520**

(Models up to serial number HDSR00032)



A Connect Hydraulics

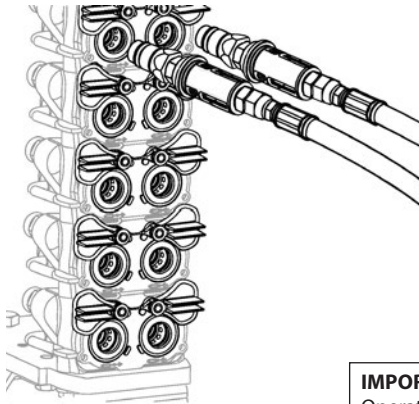

- 1 WHEELS**
- 2 SHANKS/CHOPPERS** (if equipped)
- 3 TRANSPORT/WINGS**
- 4 JACK**

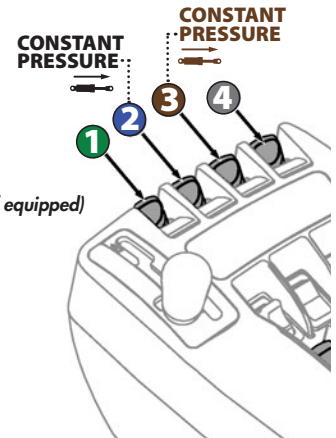

IMPORTANT: The *Shank Circuit* includes a *Pressure Reducing Valve*. Operator must engage shank circuit hydraulics **constantly** in the extended direction to ensure constant shank pressure. Adjust shank circuit and transport circuit flow down to 20-30% to reduce heat build-up.

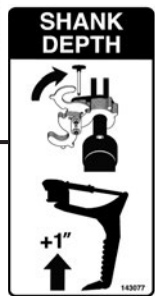
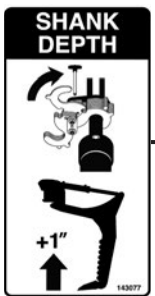
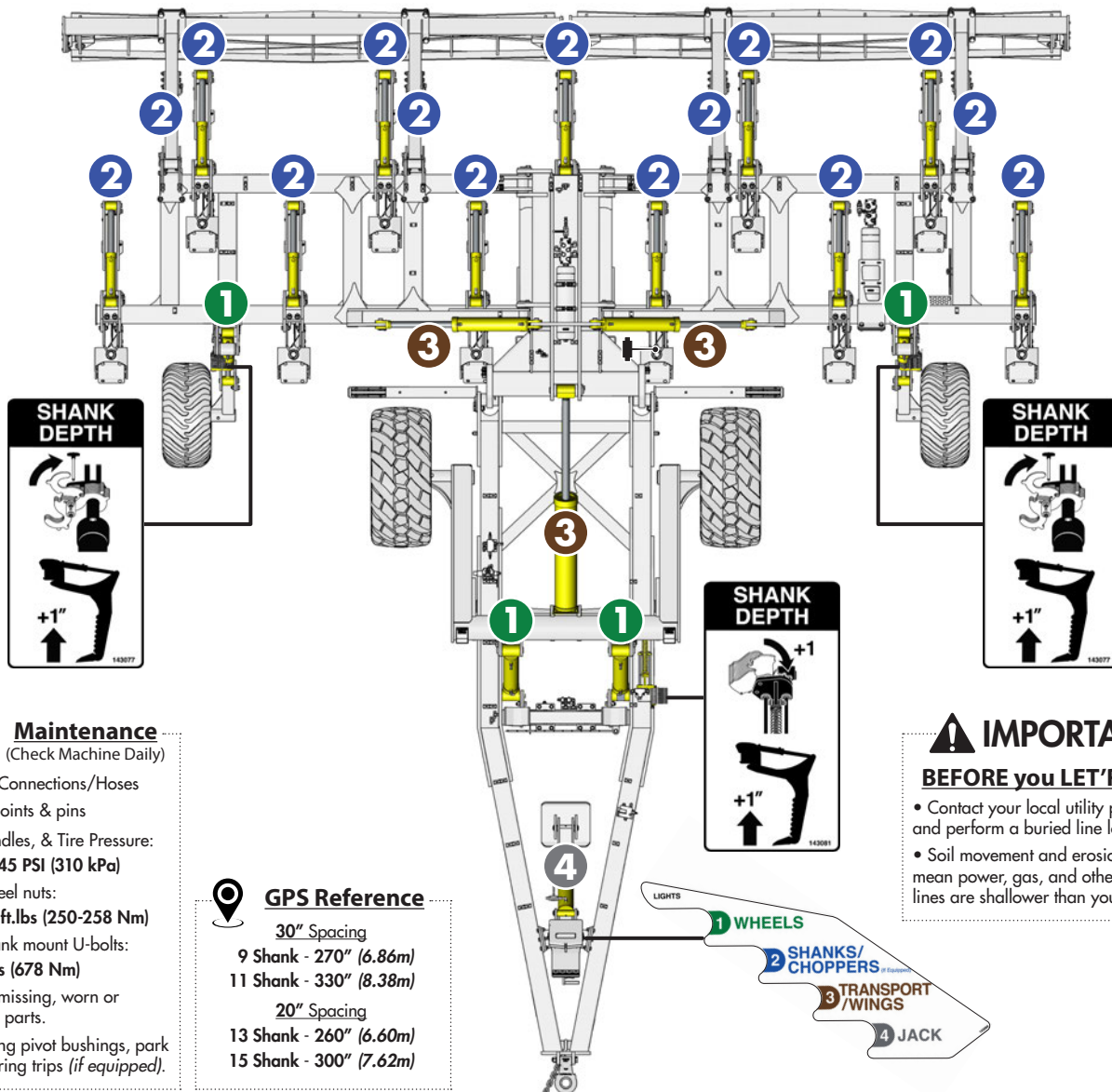

Maintenance

(Check Machine Daily)

- Hydraulic Connections/Hoses
- Working points & pins
- Hubs, Spindles, & Tire Pressure:
 - Wheels: 45 PSI (310 kPa)
- Torque wheel nuts:
 - 185-190 ft.lbs (250-258 Nm)
- Torque shank mount U-bolts:
 - 500 ft.lbs (678 Nm)
- Check for missing, worn or damaged parts.
- Grease wing pivot bushings, park jack & spring trips (if equipped).



GPS Reference

- 30" Spacing
 - 9 Shank - 270" (6.86m)
 - 11 Shank - 330" (8.38m)
- 20" Spacing
 - 13 Shank - 260" (6.60m)
 - 15 Shank - 300" (7.62m)

IMPORTANT

BEFORE you LET'R RIP:

- Contact your local utility providers and perform a buried line locate.
- Soil movement and erosion can mean power, gas, and other buried lines are shallower than you think!

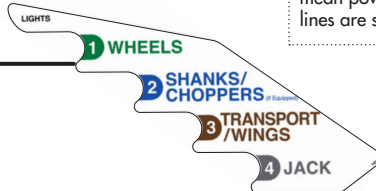

B Convert to Field Position

- i) Adjust clevis height for tractor. Machine frame should be level when in lowest transport position.
- ii) Extend wheel cylinders **1** to raise machine.



- iii) Extend wing and transport cylinders **3** to unfold.

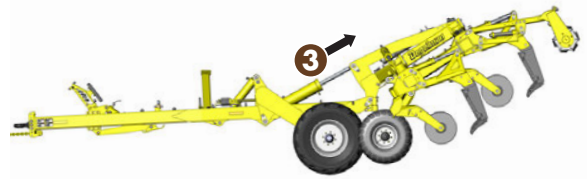
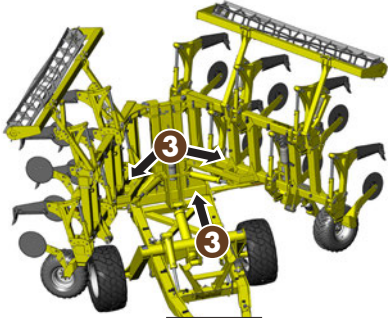

- iv) For best results, keep machine level. Activate wing remote **3** in **constant pressure** while machine is working in field.

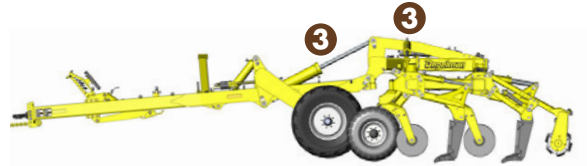

- v) **IMPORTANT:** Ensure Shank circuit **2** is set to **constant pressure** in the extended direction. (If hydraulic shank equipped.)

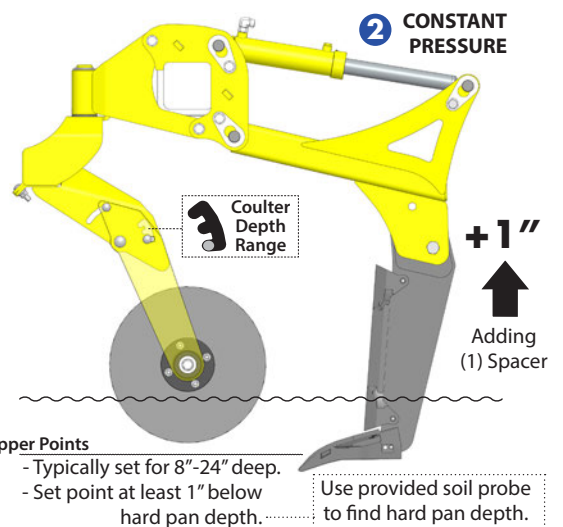

C Set Ripping Depth

- ii) Remove T-handle pin.
- iii) Rotate spacers.
- iii) Replace pins.

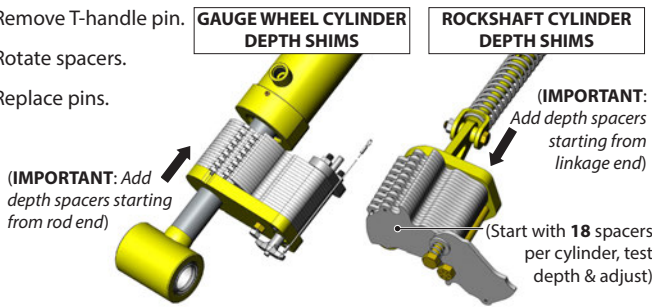

Ripper Points

- Typically set for 8"-24" deep.
- Set point at least 1" below hard pan depth.

Use provided soil probe to find hard pan depth.

Adjust Coulters Depth Based on Expected Ripping Depth

- 18"-24" - Loosen all 3 bolts with provided wrench.
- 12"-17" - Move bolt to notch for expected ripping depth.
- 6"-11" - Re-tighten all 3 bolts. (Repeat for all coulters arms.)

D Test. Check. Adjust.

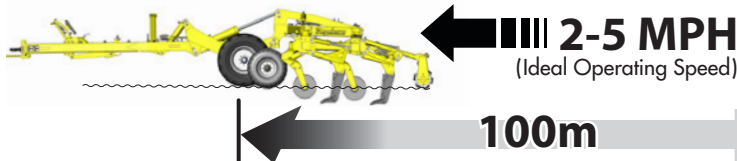

(NOTE: Ripping faster than 5 MPH increases likelihood of breaking shank shear bolts. Replace with 5/8" GR8 bolts only.)

Adjusting Shank Pressure (If hydraulic shank equipped.)

- Turn screw: ↻ Clockwise to increase pressure ↑
 ↻ Counter-clockwise to decrease pressure ↓

NOTE: 2100 psi = 3600 lb trip force (recommended)

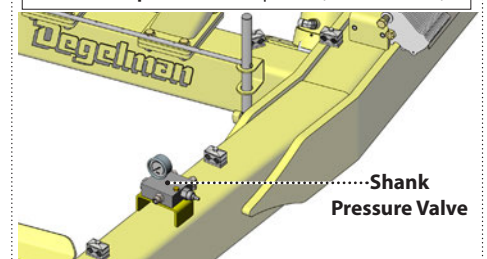

- E • Extend **1** wheel cylinders for headland turns.
- Lift machine for deep ravines/ditches.

F Converting to Transport Position

- Follow the **reverse** of steps "B" shown above.

- IMPORTANT:**
- Fully extend wheel cylinders **1** before attempting to fold in wings.
 - Leave remote **3** engaged after folding in wings so wheels **1** can be retracted to lowest transport position.
 - Ensure wing rollers are resting in transport cradles before road transport.

G MAX Transport Speed: 40 km/h (25 MPH)